

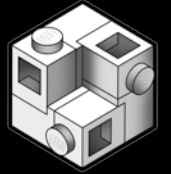

# CREATOR™



EXPERT

10266

Booklet available in English on  
Heft in deutscher Sprache erhältlich auf  
Livret disponible en français sur  
Libretto disponibile in italiano su  
Folleto disponible en español en  
Folheto disponível em português em  
A fűzet magyarul ezen a honlapon olvasható:  
Buklets latviešu valodā pieejams vietnē  
如需中文版手册, 请访问

[LEGO.com/creatorexpert](http://LEGO.com/creatorexpert)

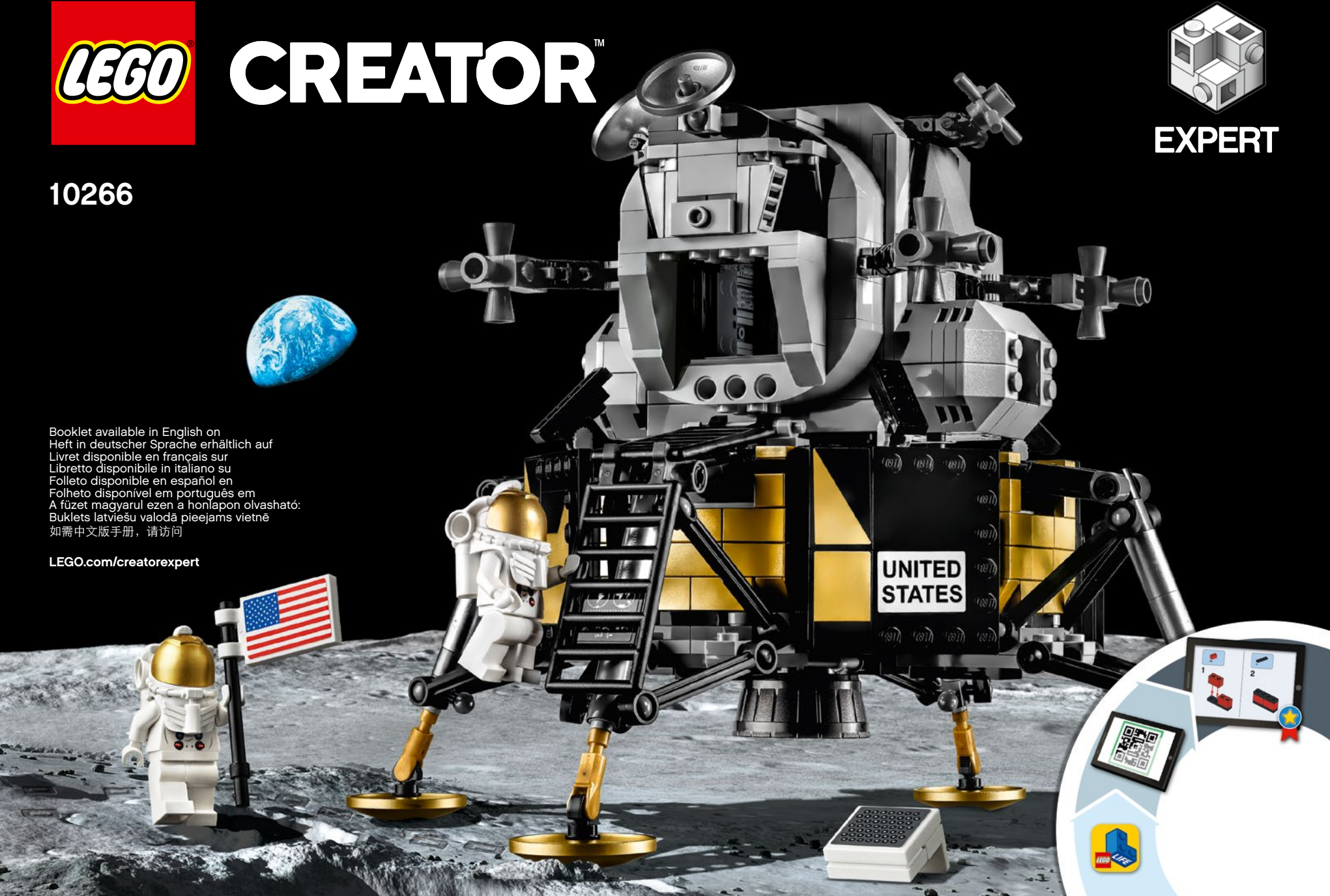

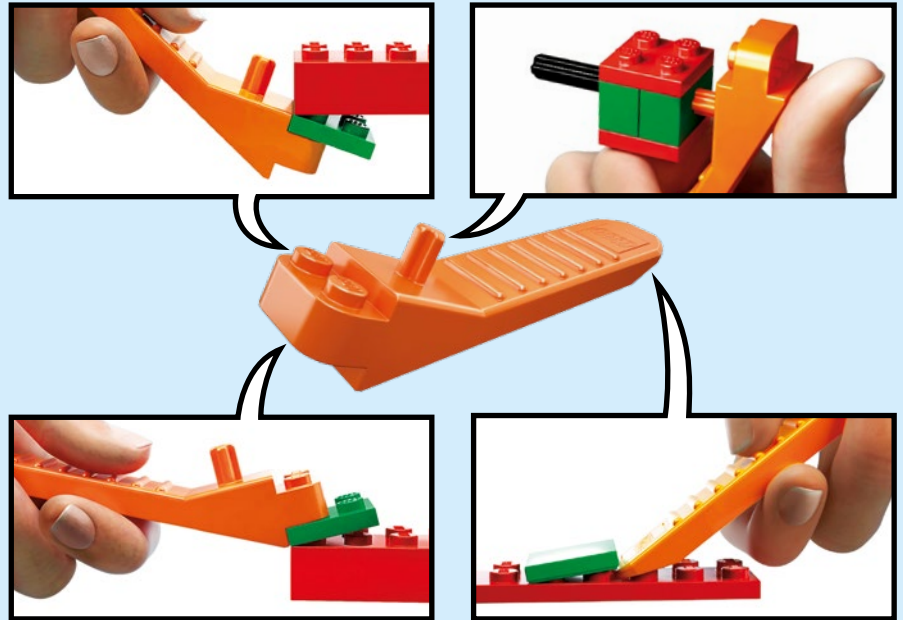

[LEGO.com/brickseparator](https://LEGO.com/brickseparator)





**1** Download the LEGO® Life App  
 Lade dir die LEGO® Life App herunter  
 Télécharge l'application LEGO® Life  
 Télécharger l'application LEGO® Life  
 Scarica l'app LEGO® Life  
 Descarga la app LEGO® Life  
 Descarrega a App LEGO® Life  
 Töltsd le a LEGO® Life Appot!  
 Lejupielādē lietotni LEGO® Life  
 下载 LEGO® Life 应用程序



**2** Scan the code on the front cover  
 Scanne den Code auf der Titelseite  
 Scanne le code sur la page de couverture  
 Scanner le code sur la page couverture  
 Scansiona il codice sulla copertina  
 Escanea el código de la portada  
 Faz scan do código na frente da capa  
 Olvasd be a borítón látható kódot!  
 Noskenē kodu uz priekšējā vāka  
 扫描封面上的二维码

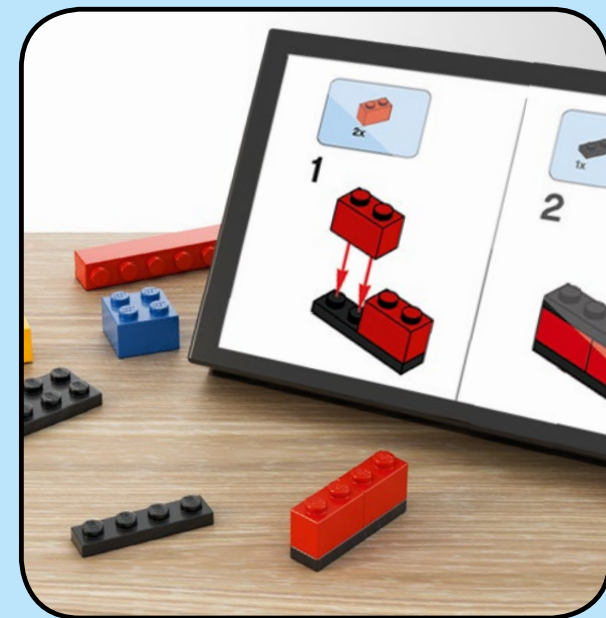

**3** Get the Building Instructions  
 Hol dir die Bauanleitung  
 Obtens les instructions de montage  
 Obtenir les instructions de montage  
 Scarica le istruzioni per la costruzione  
 Consulta las instrucciones de construcción  
 Obtém as Instruções de Construção  
 Szerezd be az építési útmutatókat!  
 Saņem būvēšanas instrukcijas  
 获取拼搭说明

**LEGO.com/apps**

Check for compatibility  
 Kompatibilität prüfen  
 Vérifier la compatibilité  
 Controlla la compatibilità  
 Comprueba tu compatibilidad

Verificar a compatibilidade  
 Ellenőrizd a kompatibilitást  
 Pārbaudīt saderību  
 检查兼容性



“We choose  
to go to  
the Moon”

## The Race to the Moon

Humanity's sense of wonder, fascination and awe of space is as old as humanity itself. But our desire to explore the universe beyond the realms of earth did not take flight until the 1960s. Following John F. Kennedy's declaration that America would put a man on the Moon (and return him safely to Earth) by the end of the 1960s, NASA led the way, placing the USA firmly at the front of the global race to explore space.

Others may have ventured into the vacuum of space, but it was on the 20th of July 1969, that a human footprint first made contact with the surface of the Moon. The landing of the Apollo Lunar Lander was broadcast live to a global audience. It was a moment that captivated the world and changed space travel forever.

TORONTO, WEDNESDAY, JULY 16, 1969

10 CENTS

# OFF TO THE MOON

By JOHN AITKEN  
Telegram Staff Reporter

CAPE KENNEDY — Apollo  
space today, carrying three Americans  
first landing on the moon.  
...well, Neil Armstrong  
the surface





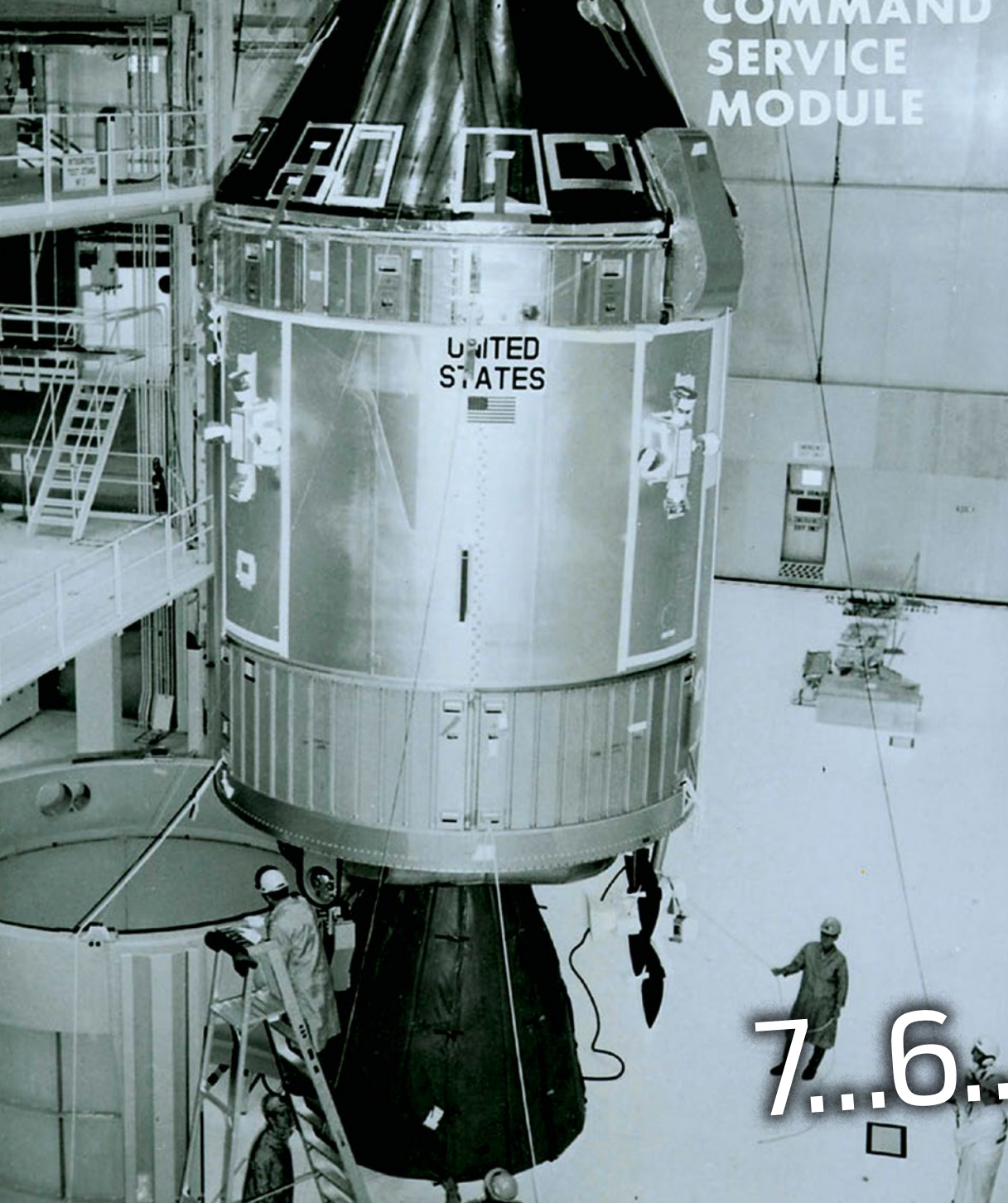



**Did you  
know...**

**...it was a lingerie  
manufacturer who won  
the contract to develop  
the spacesuits worn by  
the crew of Apollo 11?**

**... the craft of  
'weaving' by female  
factory workers  
inspired the core  
rope memory of the  
onboard guidance  
computer?**

**...And lift off!**



## **A Pioneering Vehicle**

The Apollo 11 Lunar Lander "Eagle" was an extraordinary vehicle, representing the first crewed vehicle to land anywhere beyond Earth, and the vehicle that brought the first man onto the Moon.

But more than that, the fragile-looking spacecraft represents humankind's curiosity, ingenuity, technological skill, determination and bravery. It illustrates how creative lateral thinking and perseverance can bring immense advances for the benefit of all mankind.



## **A Tribute to Creativity and Innovation**

This LEGO® Creator Expert tribute to the Apollo 11 Lunar Lander represents something truly astonishing, an authentic human marvel. Even now, over 50 years later and with the many changes we have experienced in our lifetimes, this vehicle was part of the creative and technological drive to put a human past the comfort zone of our atmosphere. The Apollo 11 Lunar Lander allowed us to venture into the vast unknown of space and touchdown on the Moon, and that is truly astounding.



...Go for landing...

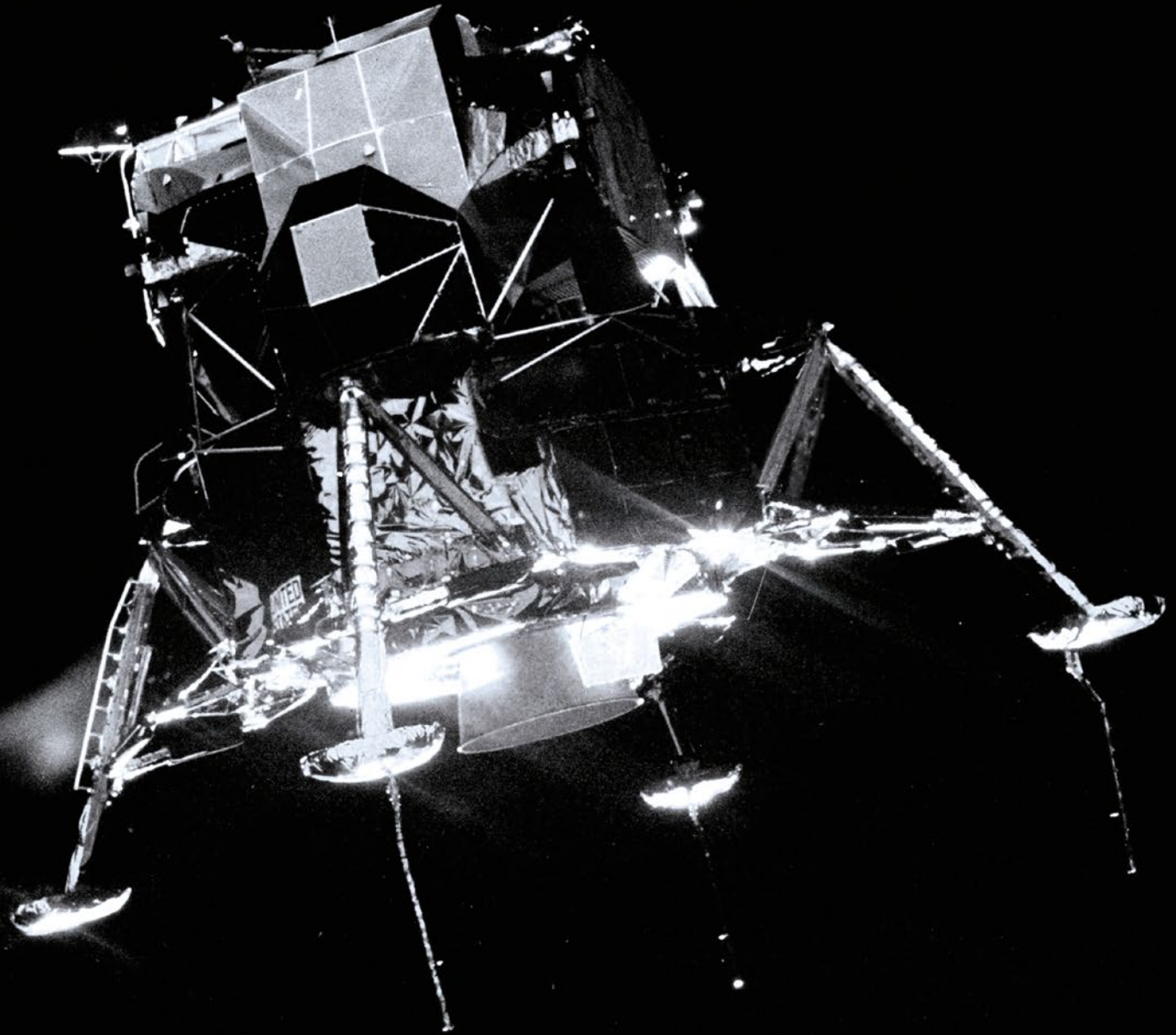

# About NASA

In 1958, the National Aeronautics and Space Act was passed, expressing that “It is the policy of the United States that activities in space should be devoted to peaceful purposes for the benefit of all mankind.” As a result, the National Aeronautics and Space Administration (NASA) was founded over 60 years ago for the purpose of leading the peaceful exploration of space, making discoveries about the Earth, its solar system, and the universe.

Since then, NASA research has not only led to the exploration of space, it has made great advances in aviation, helped to develop a commercial space industry, enriched the US economy, created jobs, and strengthened national security.

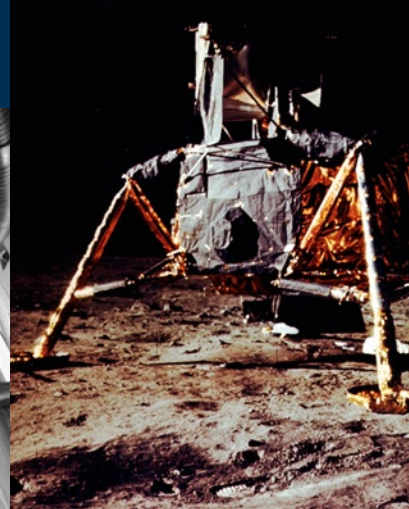

# The Apollo Program

It was after a series of earlier Mercury, Gemini and Apollo missions, as well as the work of thousands of expert scientists, engineers and astronauts, that Neil Armstrong and Buzz Aldrin landed the Lunar Module on July 20th, 1969 and walked on the Moon. The entire program ran from 1961 to 1972 and set several human spaceflight milestones. Apollo 8 was the first manned spacecraft to orbit another celestial body, while the final Apollo 17 mission was the sixth Moon landing. The program was not only groundbreaking in terms of space exploration, it catalyzed technological development in avionics, telecommunications and computers.

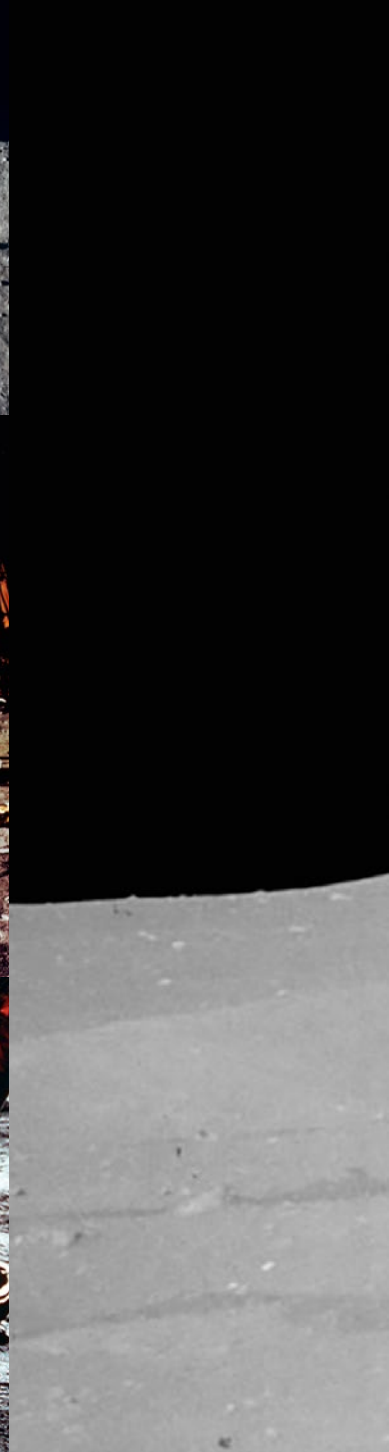



“The Eagle has landed”

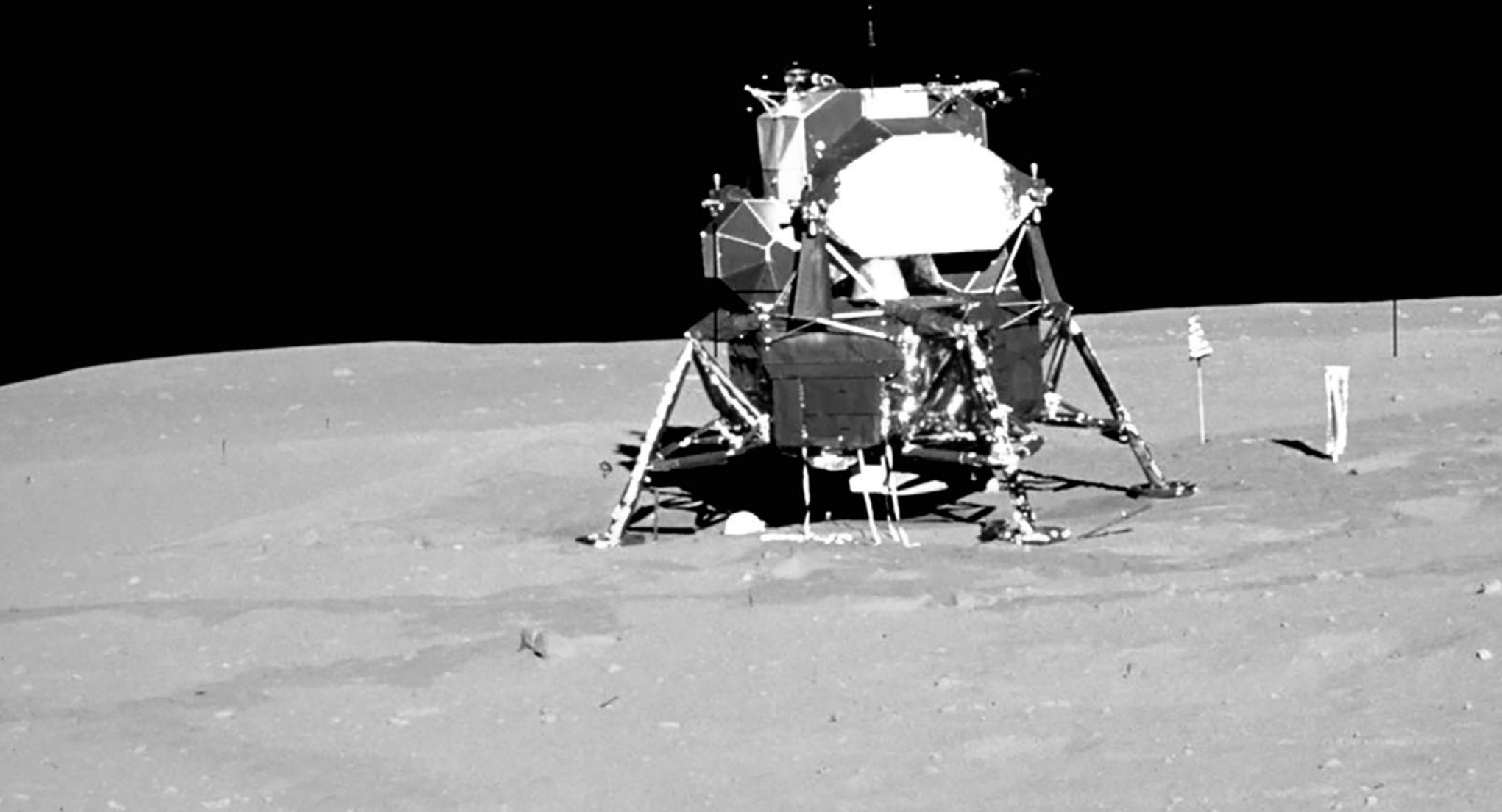

# The Apollo 11 Mission Key Moments



July 16, 1969 - Apollo 11, the first manned space flight to land on the Moon, launched into space.



July 17, 1969 - Astronauts Neil Armstrong, Michael Collins and Edwin 'Buzz' Aldrin made their first TV transmission to Earth from space.



July 20, 1969 - Armstrong and Aldrin boarded the Lunar Lander "Eagle" and disengaged from the Apollo Command Module "Columbia."

The Lunar Lander touched down on the Moon in the "Sea of Tranquility."

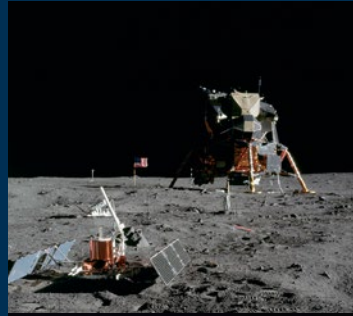

The two astronauts spoke to President Richard M. Nixon from the Moon's surface. They spent 2.5 hours collecting samples, setting up equipment, taking pictures and leaving special items.



July 21, 1969 - After a rest period for the astronauts, the module ascended and returned to Command Module Columbia and docked, reuniting Armstrong and Aldrin with Collins. The Lunar Lander was then jettisoned into lunar orbit.



July 22, 1969 - On the way back to Earth, a midcourse correction and two more television transmissions were made.



July 24, 1969 - The Apollo 11 capsule and astronauts on board landed back on Earth, splashing down into the Pacific Ocean.





“That’s one small step for (a) man,  
one giant leap for mankind”



# Get to Know Your Lunar Lander

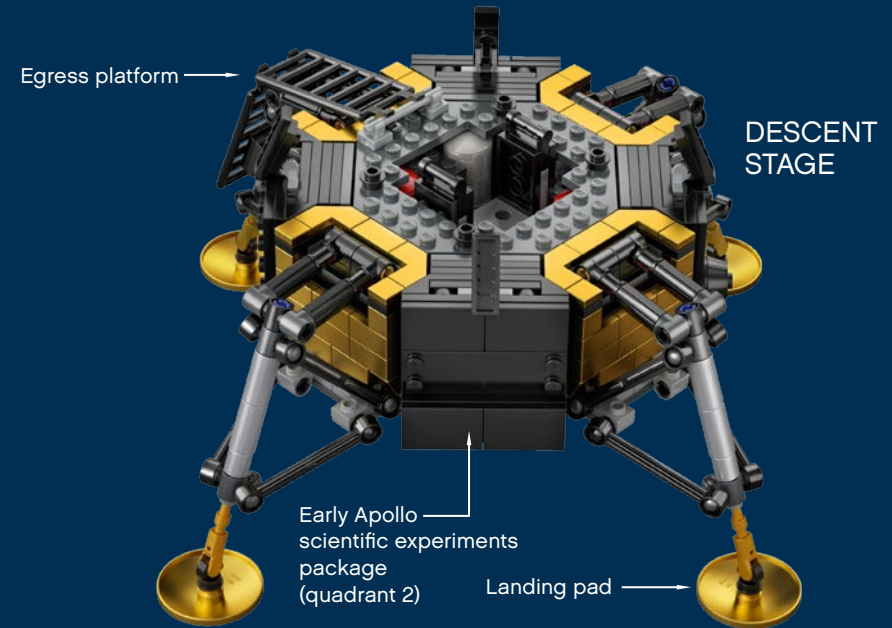
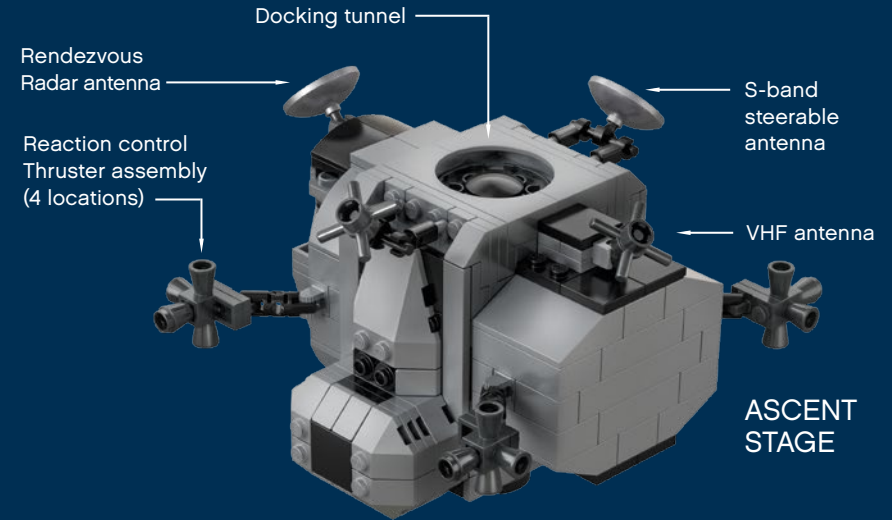
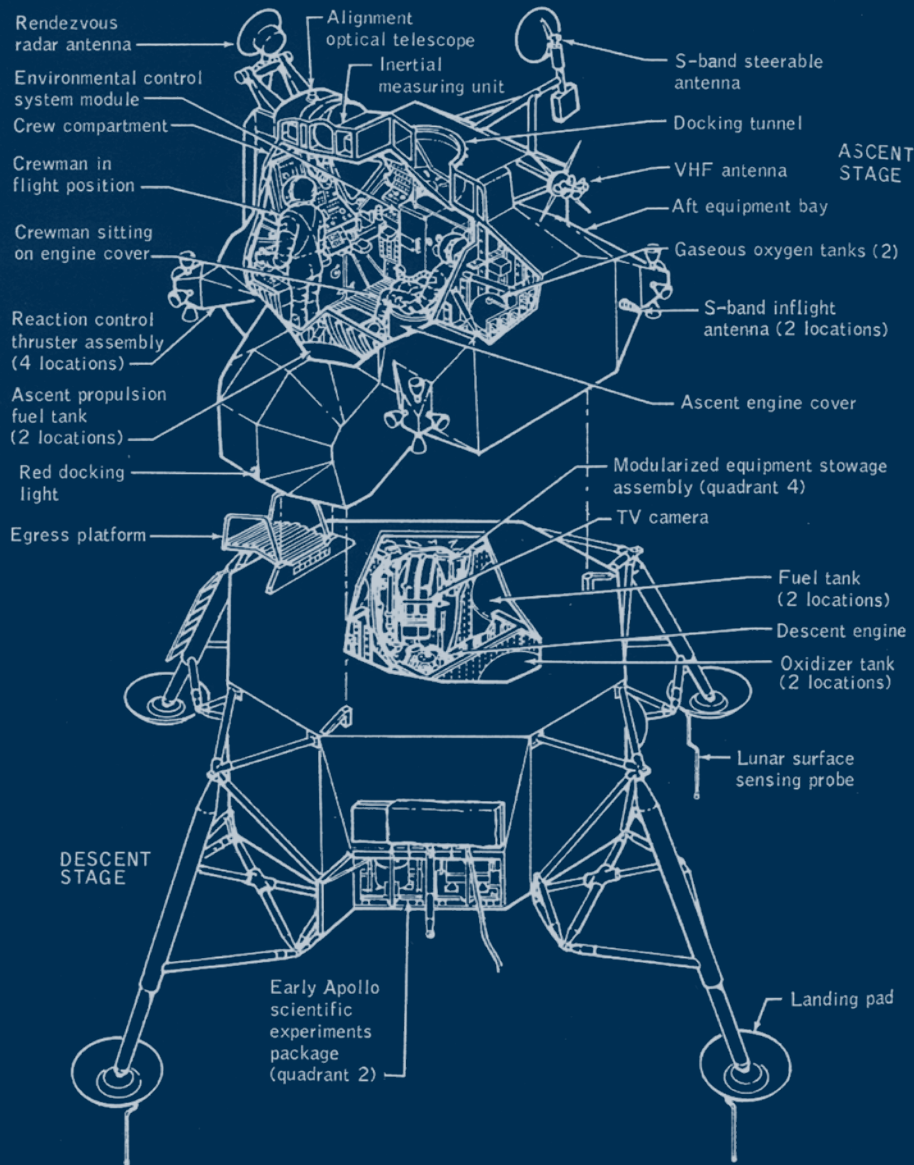

LUNAR MODULE CONFIGURATION FOR INITIAL LUNAR LANDING





**Lars Joe Hylding**  
*Design Manager Specialist*

## Facts from the LEGO® Designer

For both the actual Lunar Lander and our LEGO® tribute, blueprints like these are the beginning of every design process. This is how the design of the original module was translated into LEGO bricks.

The golden bricks represent the foil that the Lunar Lander was wrapped in, for thermal and micrometeoroid protection. The two main elements of the Lunar Lander are the ascent stage and the descent stage. On the ascent stage, among other things, I focused mostly on the “face” with the two windows and the door. The ascent stage has a lot of angles that I had to build in a more simplified way do to the scale. On the descent stage, among other things, I focused on capturing the octagon shape, the legs, and the shiny foil.

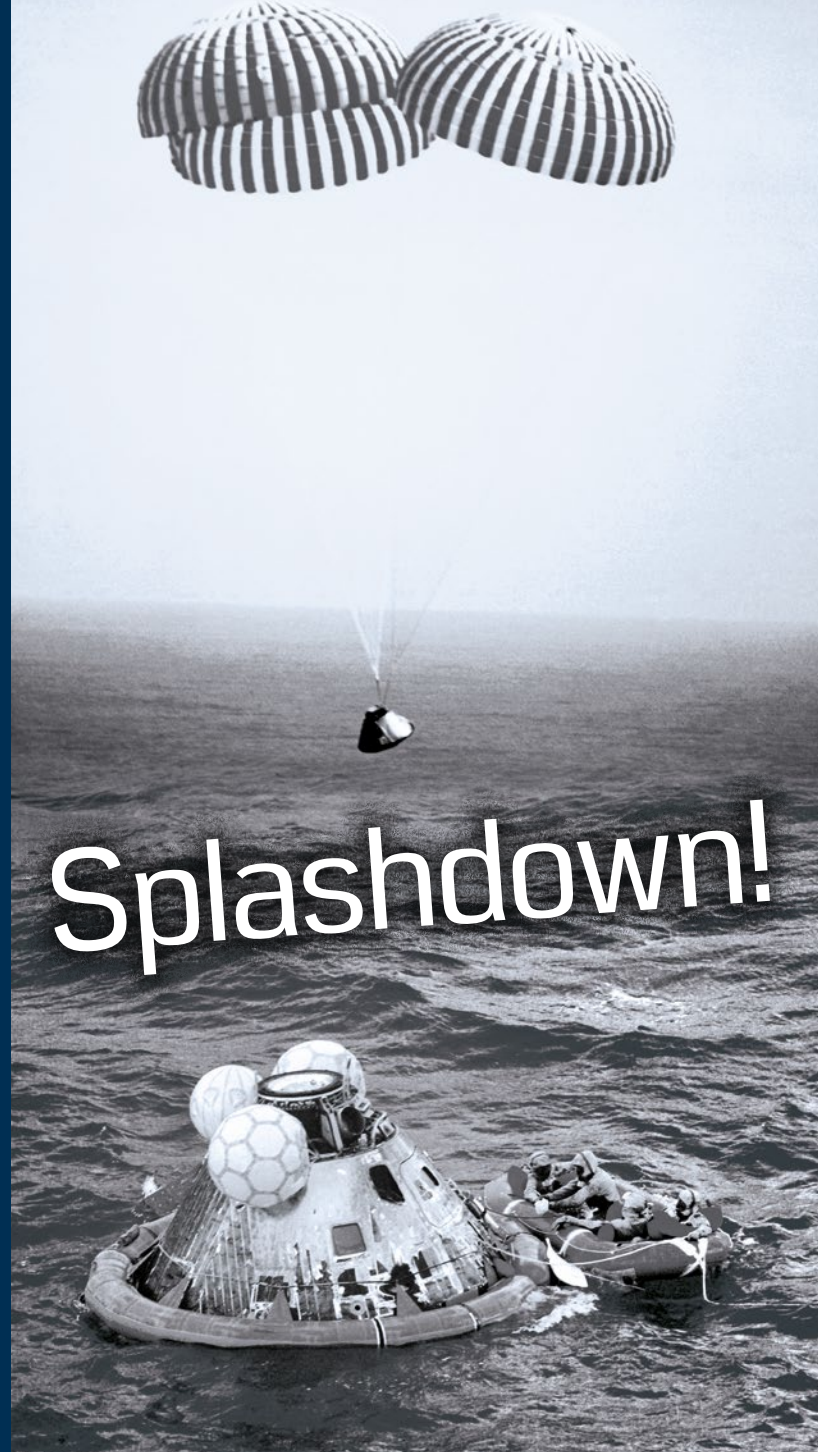

## Did you know...

...designed by MIT, the computer on board the Lunar Lander, the Apollo Guidance Computer (AGC), provided the guidance, navigation and control of the spacecraft. The computer's performance was comparable to first-generation home computers available in the late 1970s, but is similar to a simple calculator today.



## We Came in Peace ...

Humankind's initial step on the surface of a celestial object was born out of a race to be the first; the Moon landing, made possible by the Lunar Lander, was a huge achievement for American technological pride and prowess, as well as a tremendous moment for all humanity.

John F. Kennedy's bold and ambitious call to action did not end with the successful Apollo 11 mission; it set off a new era for NASA and for humanity's exploration of the unknown. NASA's work today still focuses on technological innovation and discovery, pushing boundaries toward human exploration of the Moon and Mars, and reaching beyond to find the answer to the question, "Are we alone?"

## What was Left Behind

Many things were left on the Moon after that initial landing by the Eagle. Part of the descending rocket for returning the astronauts back to Earth, as well as the laser reflector and the footprints of the two astronauts still remain on the moon.

They also left an Apollo 1 mission patch, a memorial bag with a gold replica of an olive branch as a traditional symbol of peace, and a silicon message disk with the goodwill statements of U.S. presidents Eisenhower, Kennedy, Johnson and Nixon, and messages from leaders of 73 countries around the world.

Commemorative medallions were also left on the surface of the Moon, that honor the memories of the Apollo 1 astronauts who lost their lives in a launchpad fire, and two cosmonauts who also died in accidents.





**“To discover and  
expand knowledge for the  
benefit of humanity.”**



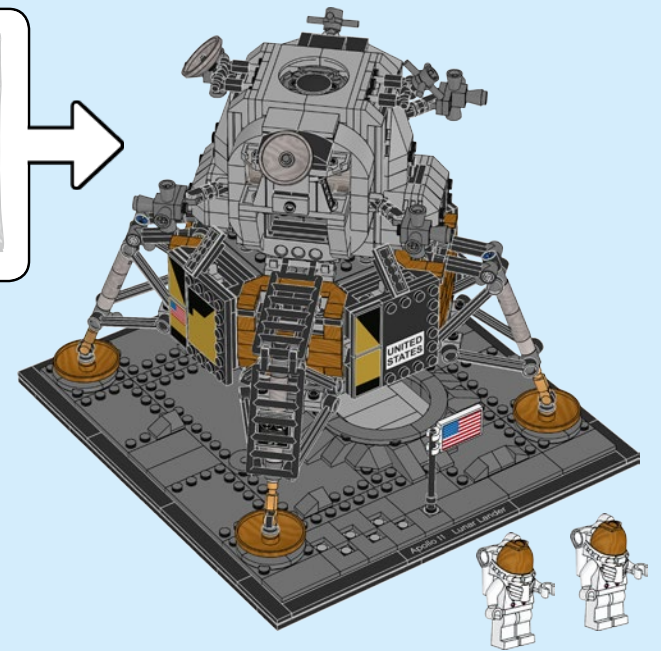
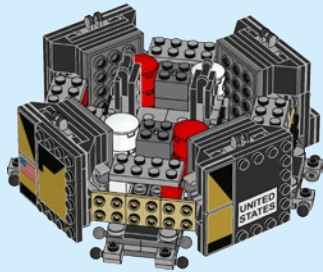
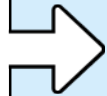
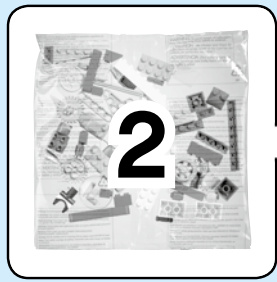
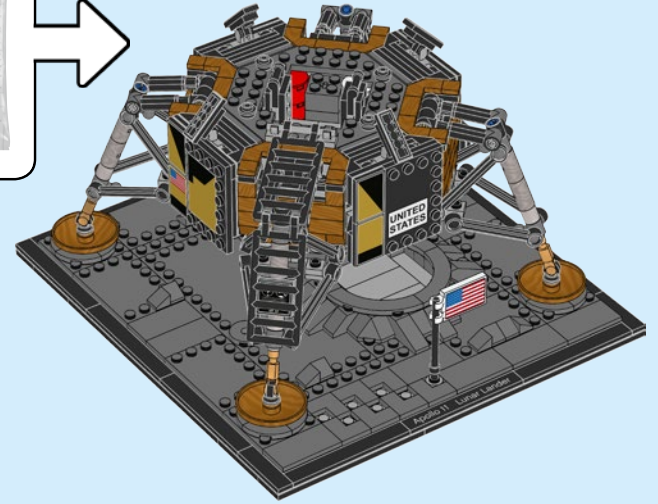
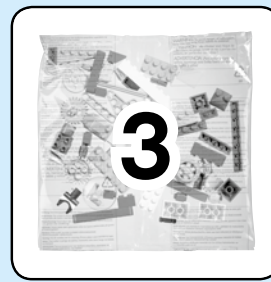
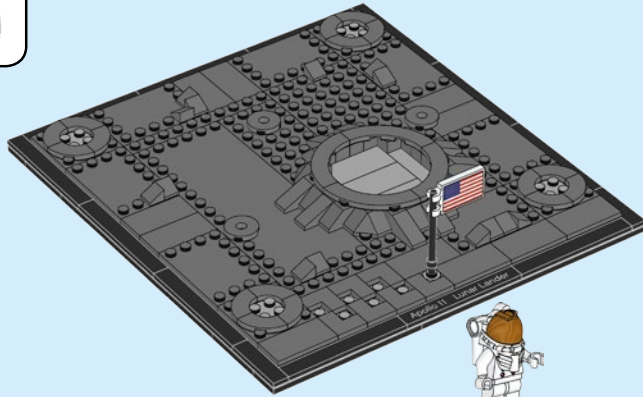
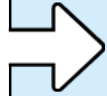



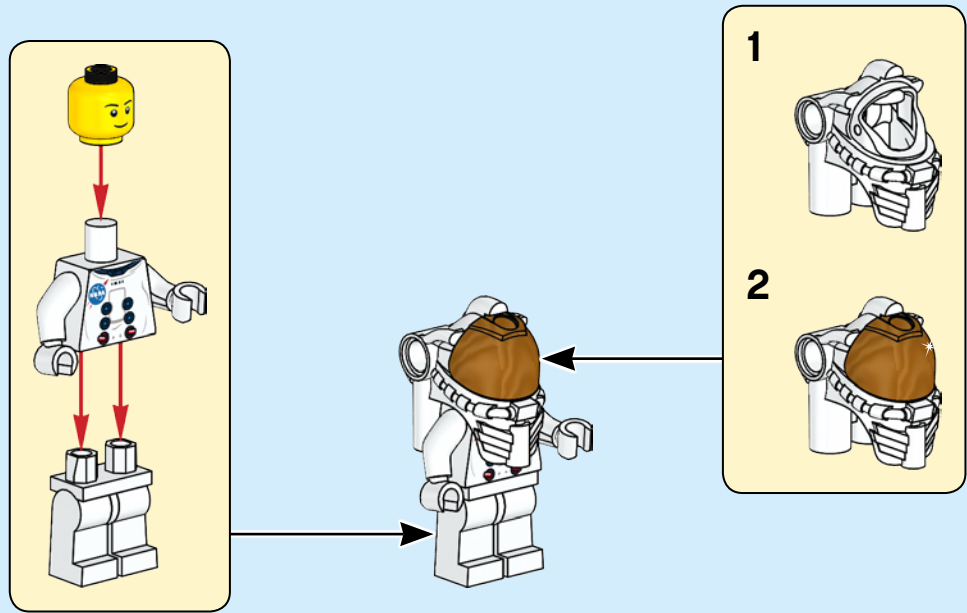
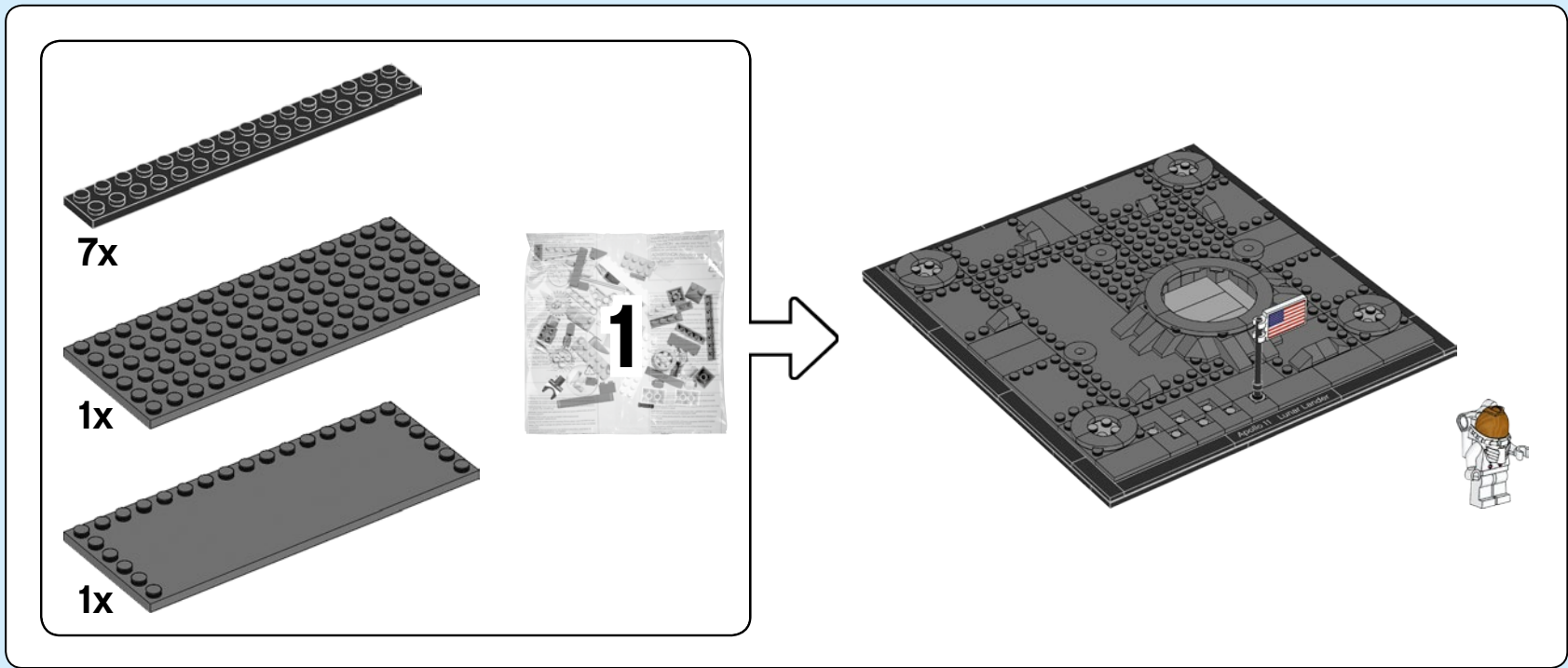

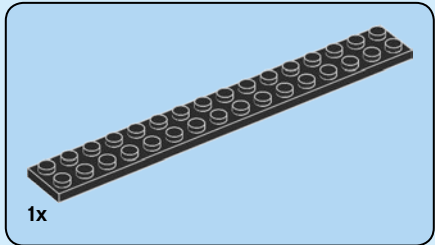
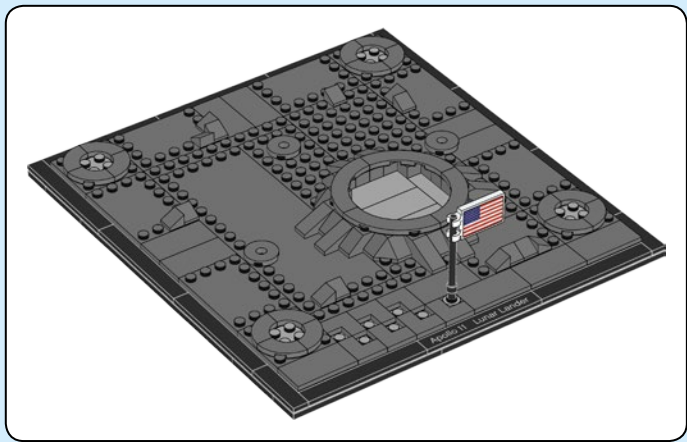

1x

**1**

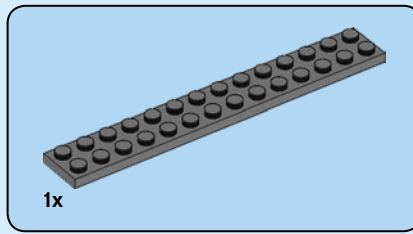
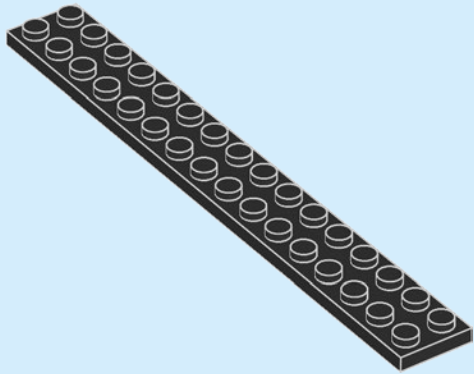

1x

**2**

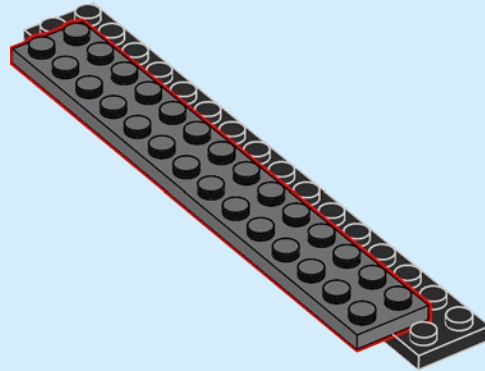



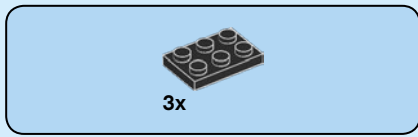

3

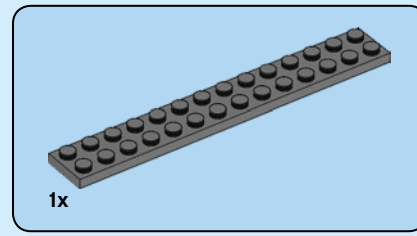
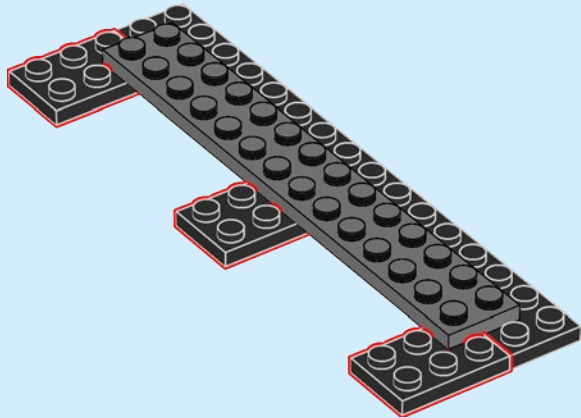

4

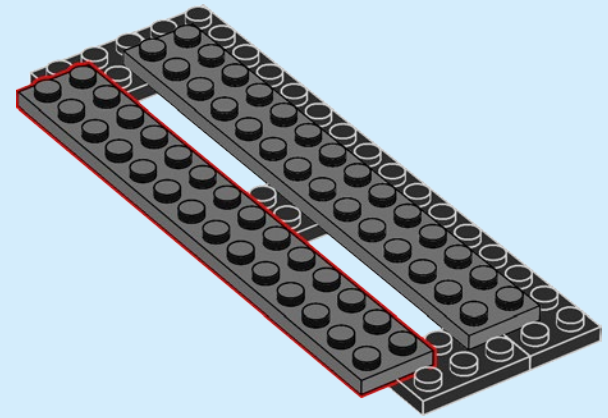

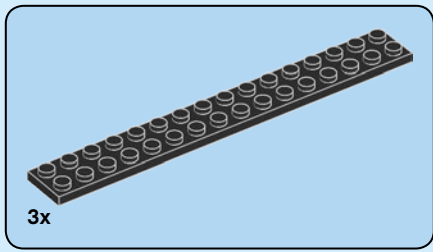

5

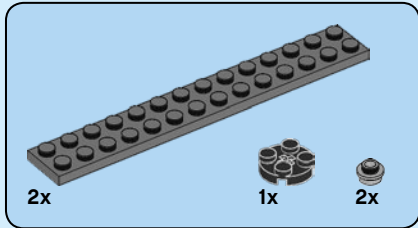
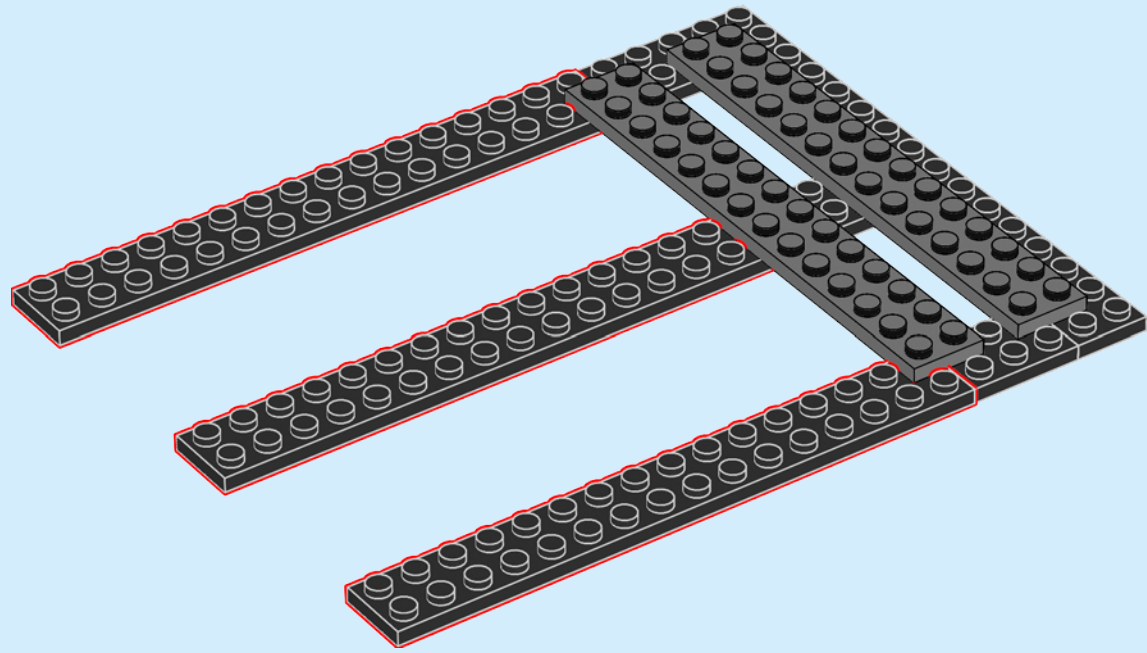

6

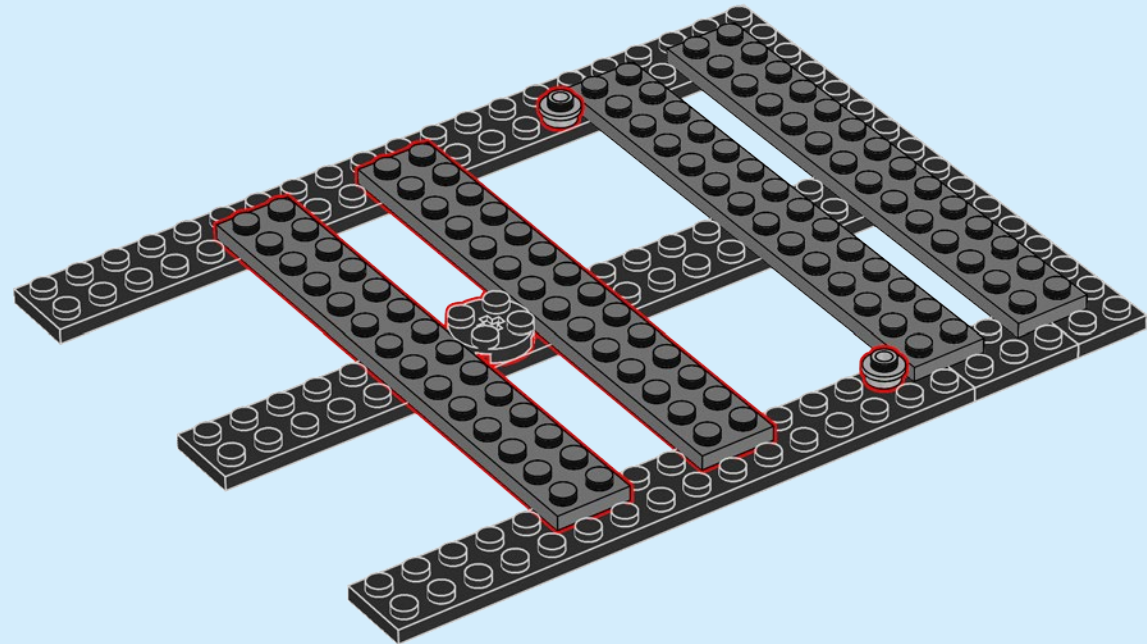



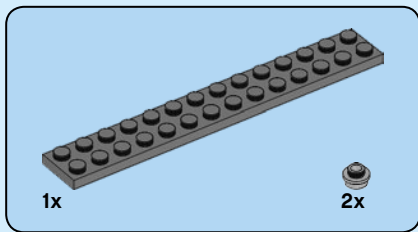

7

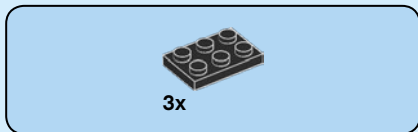
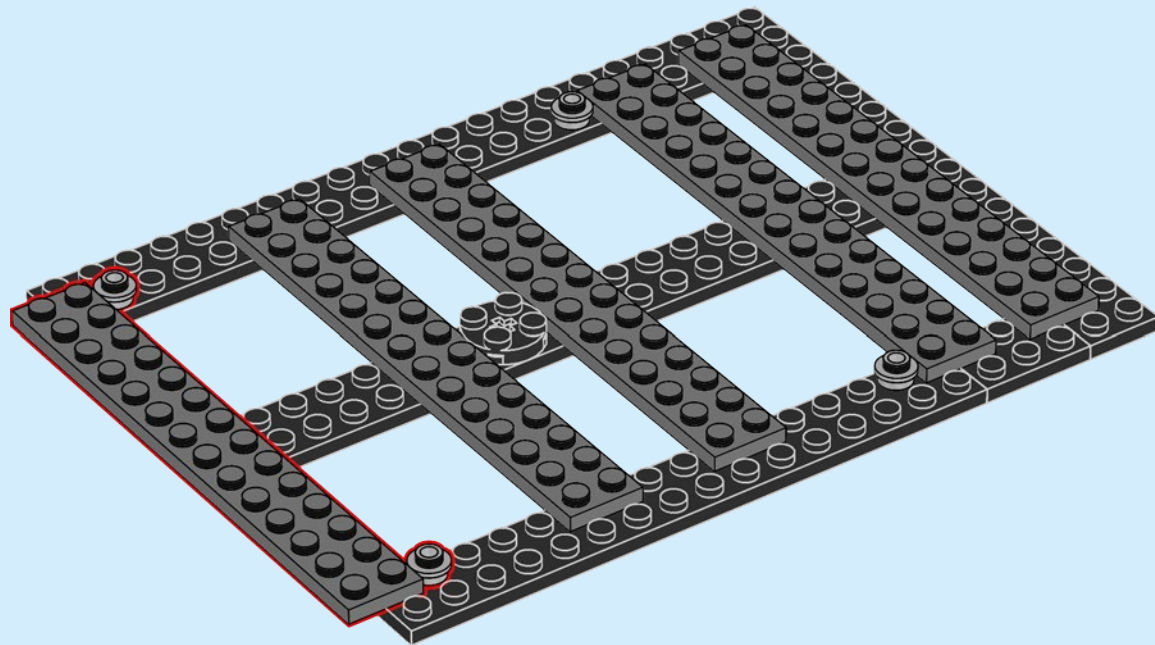

8

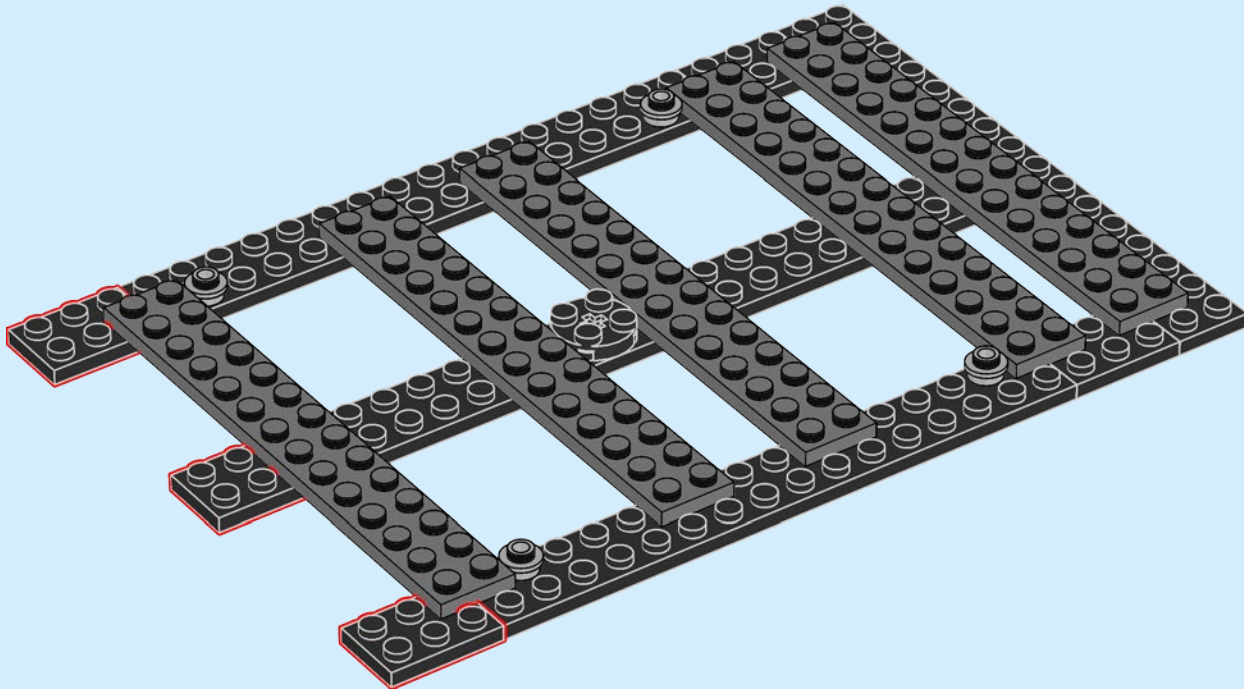

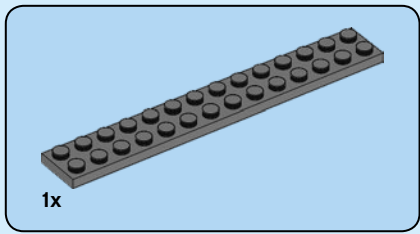

1x

9

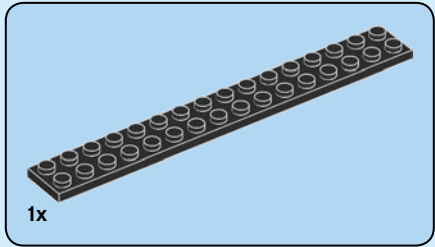
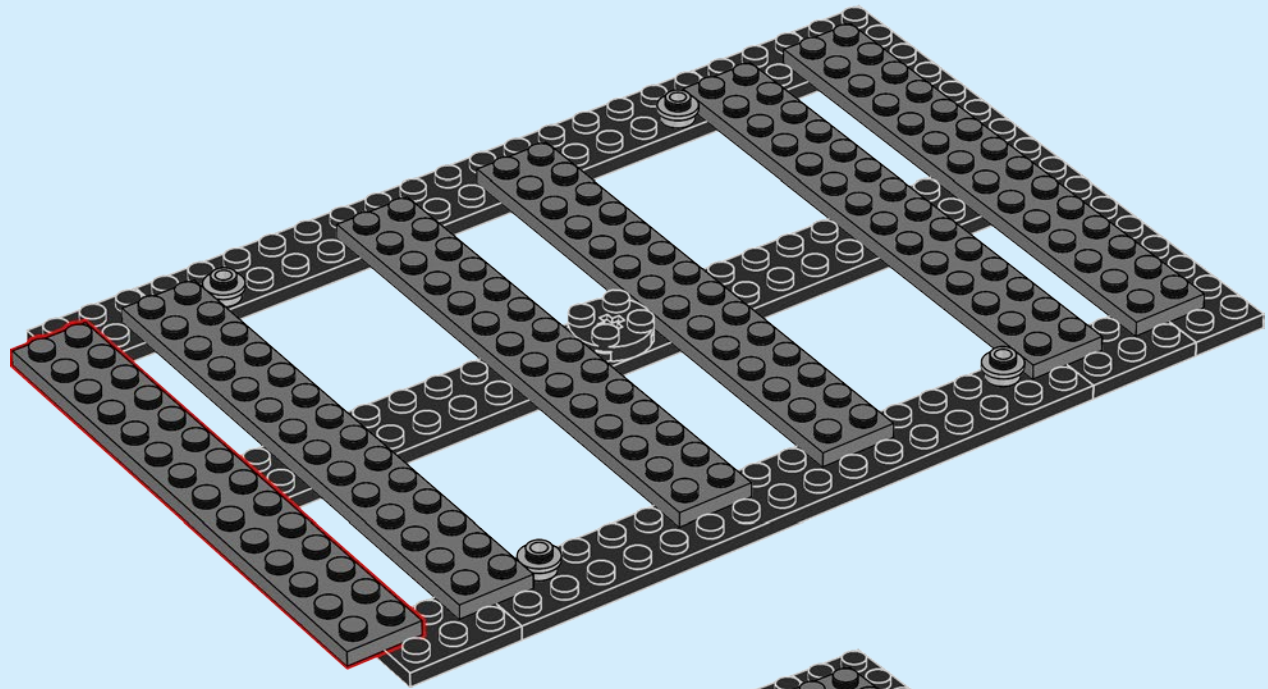

1x

10

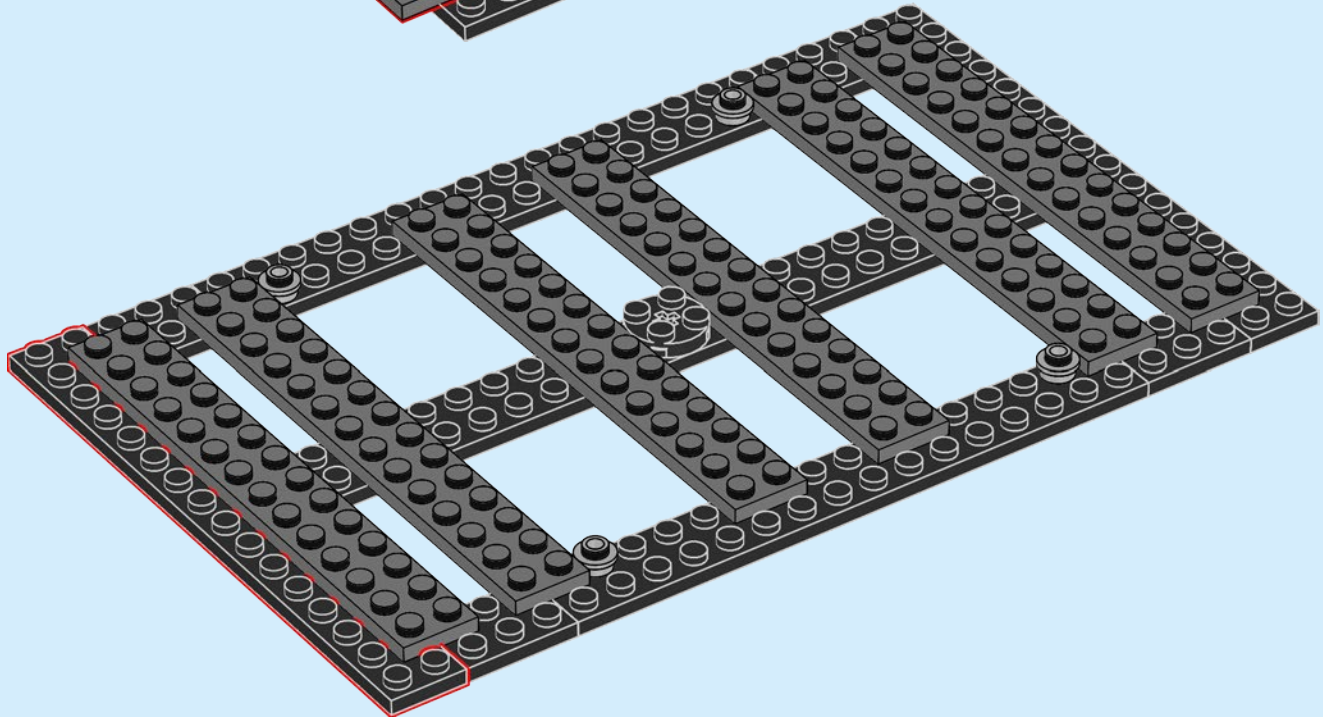



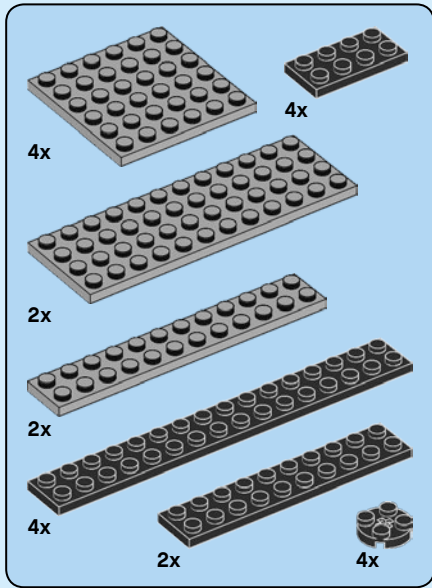
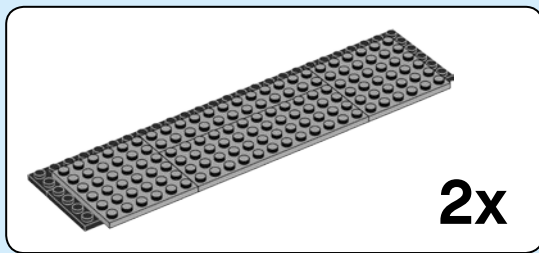

11

1

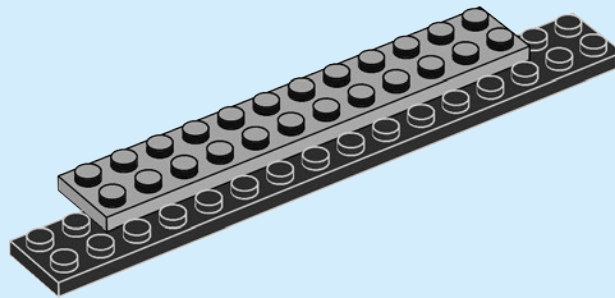

2

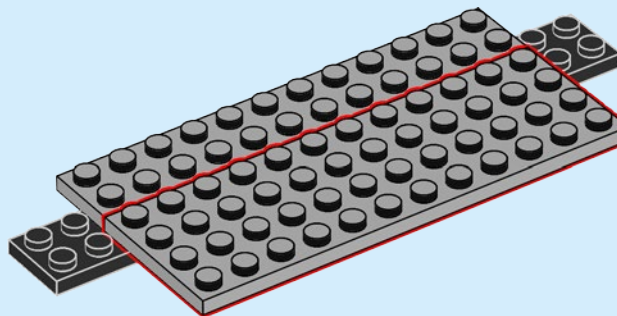

3

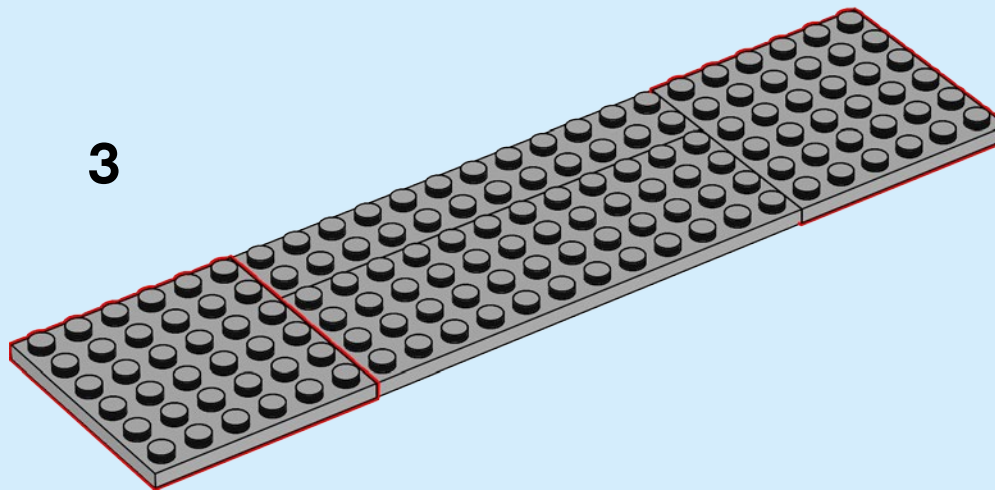



4

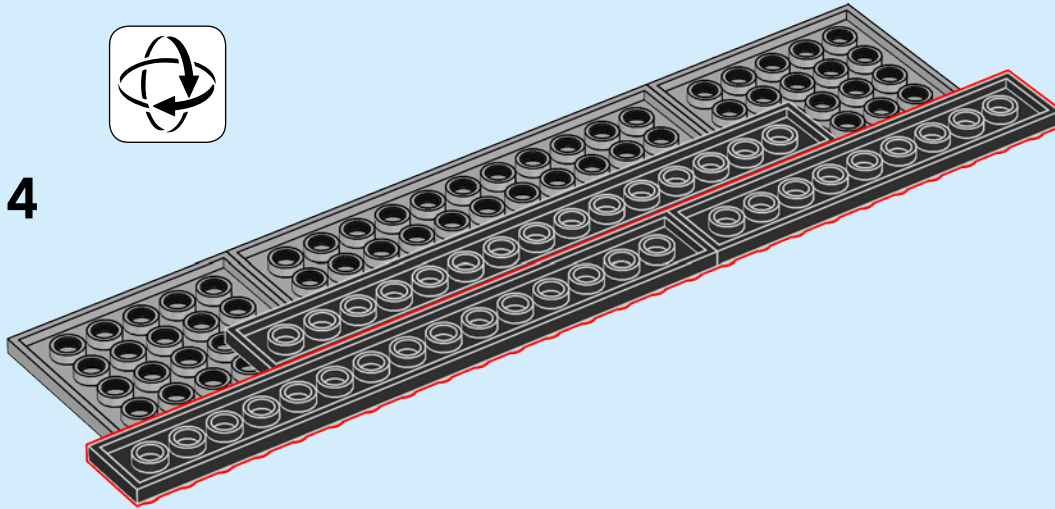

5

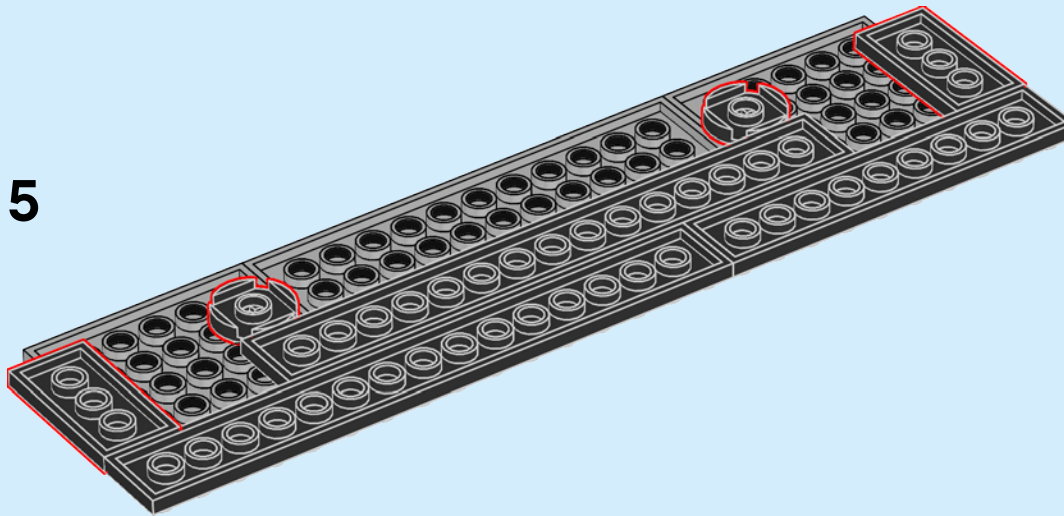

2x



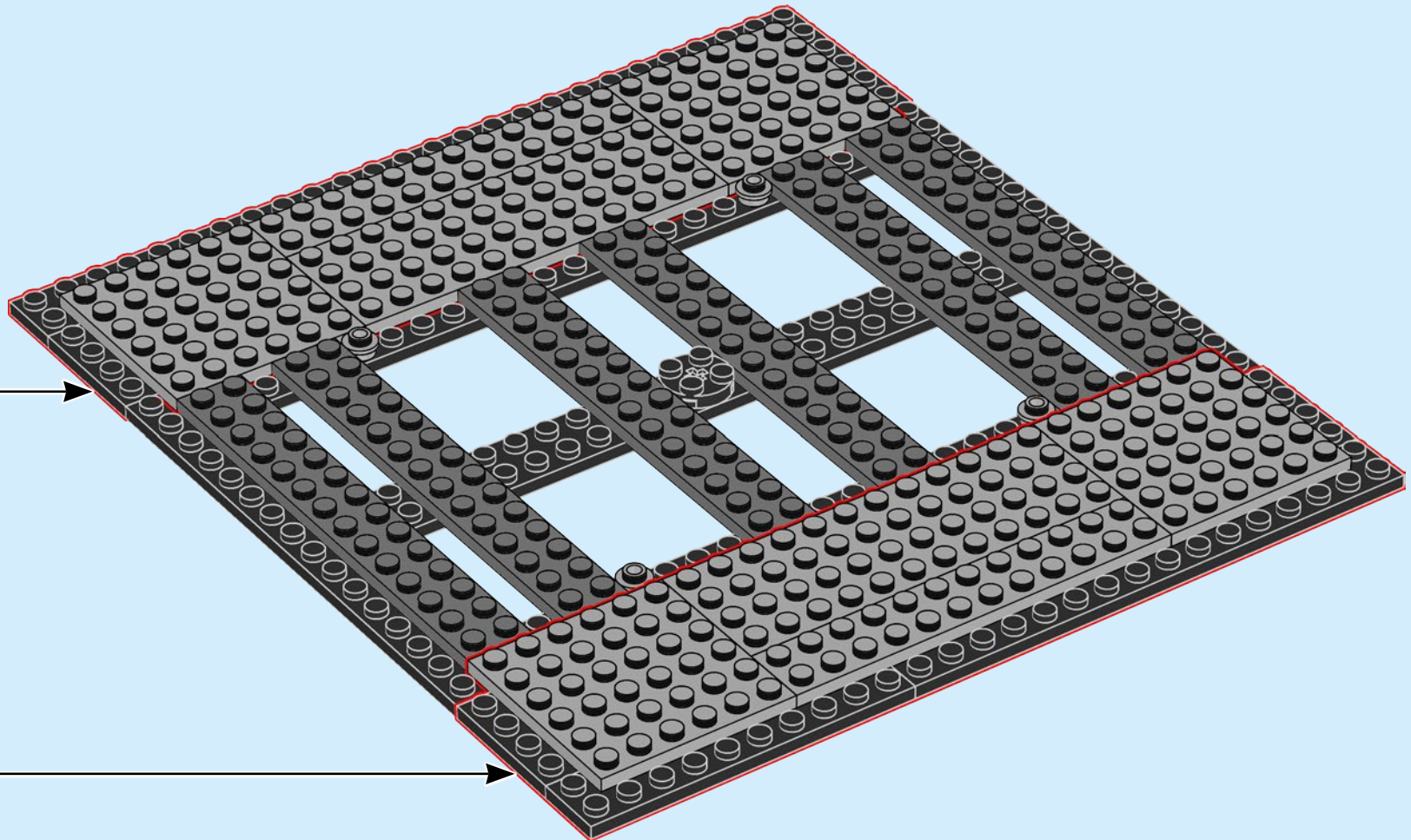

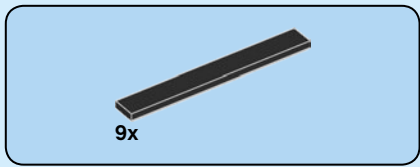

12

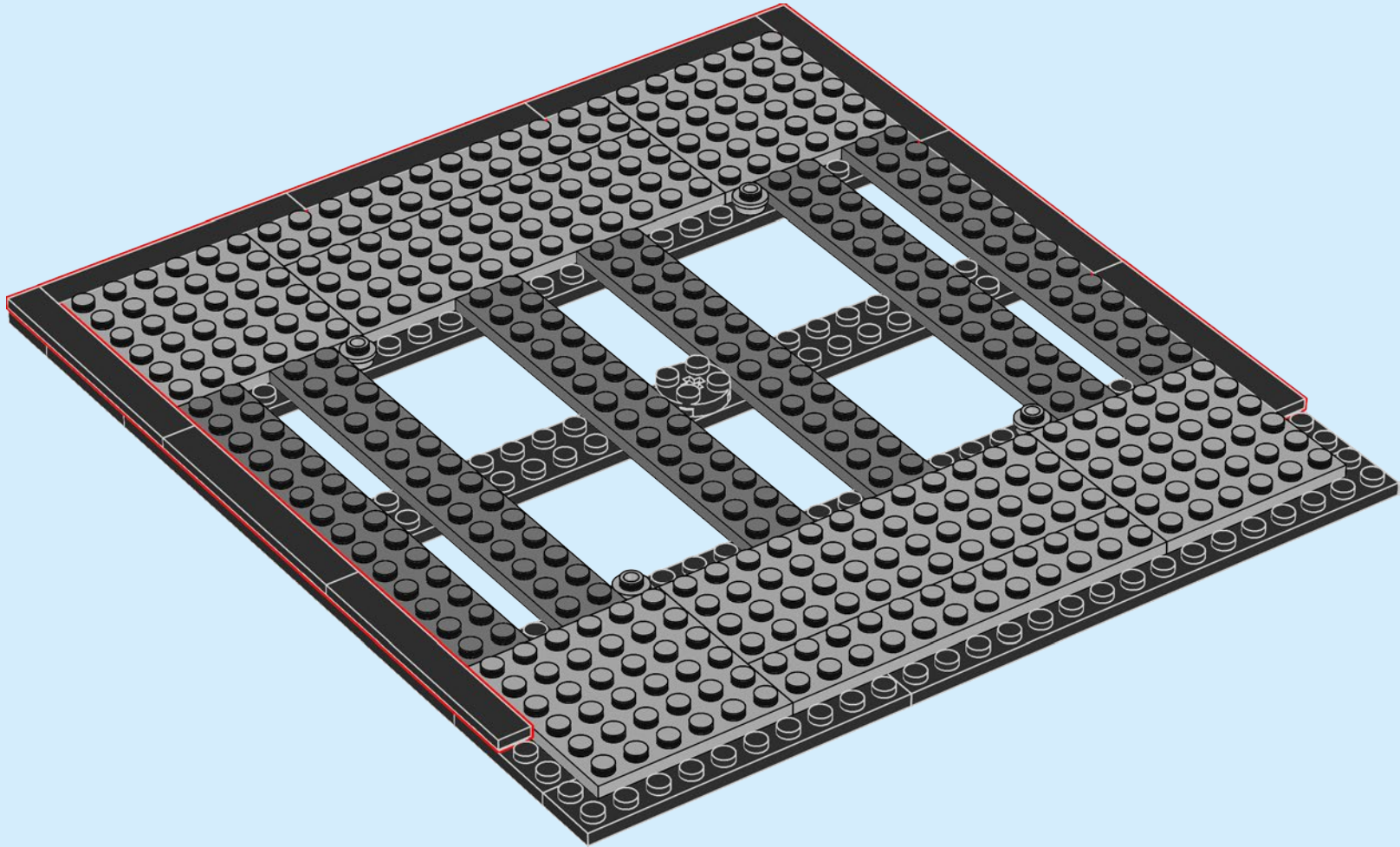



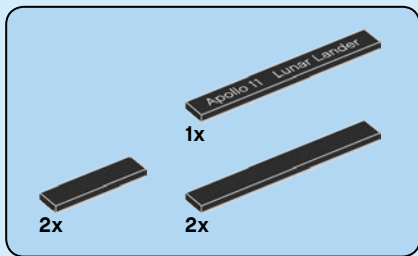

13

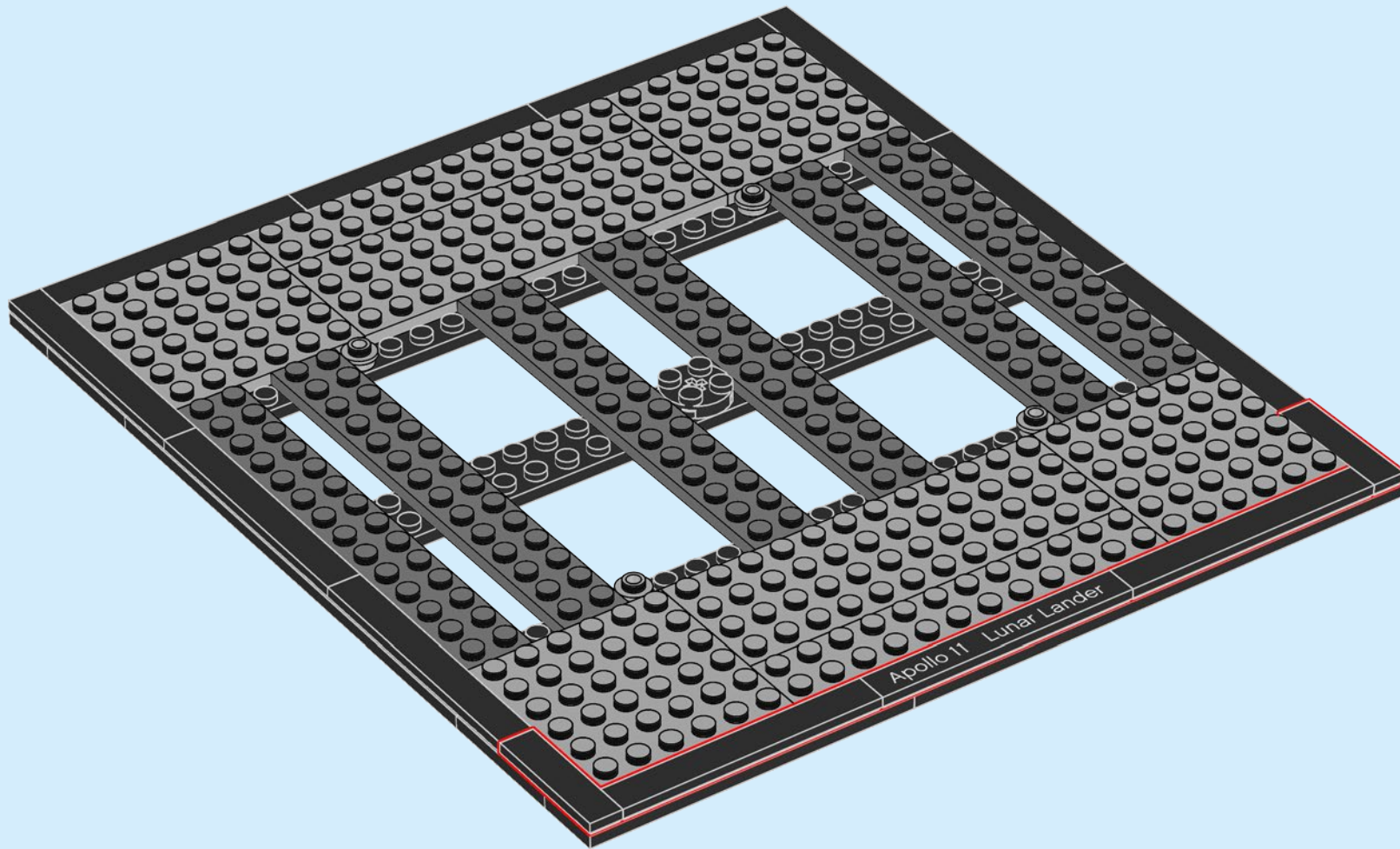

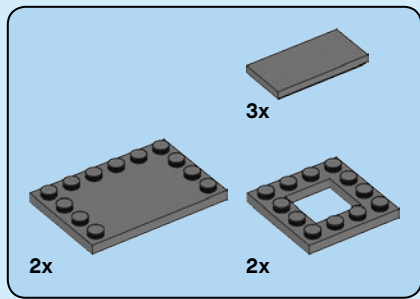

14

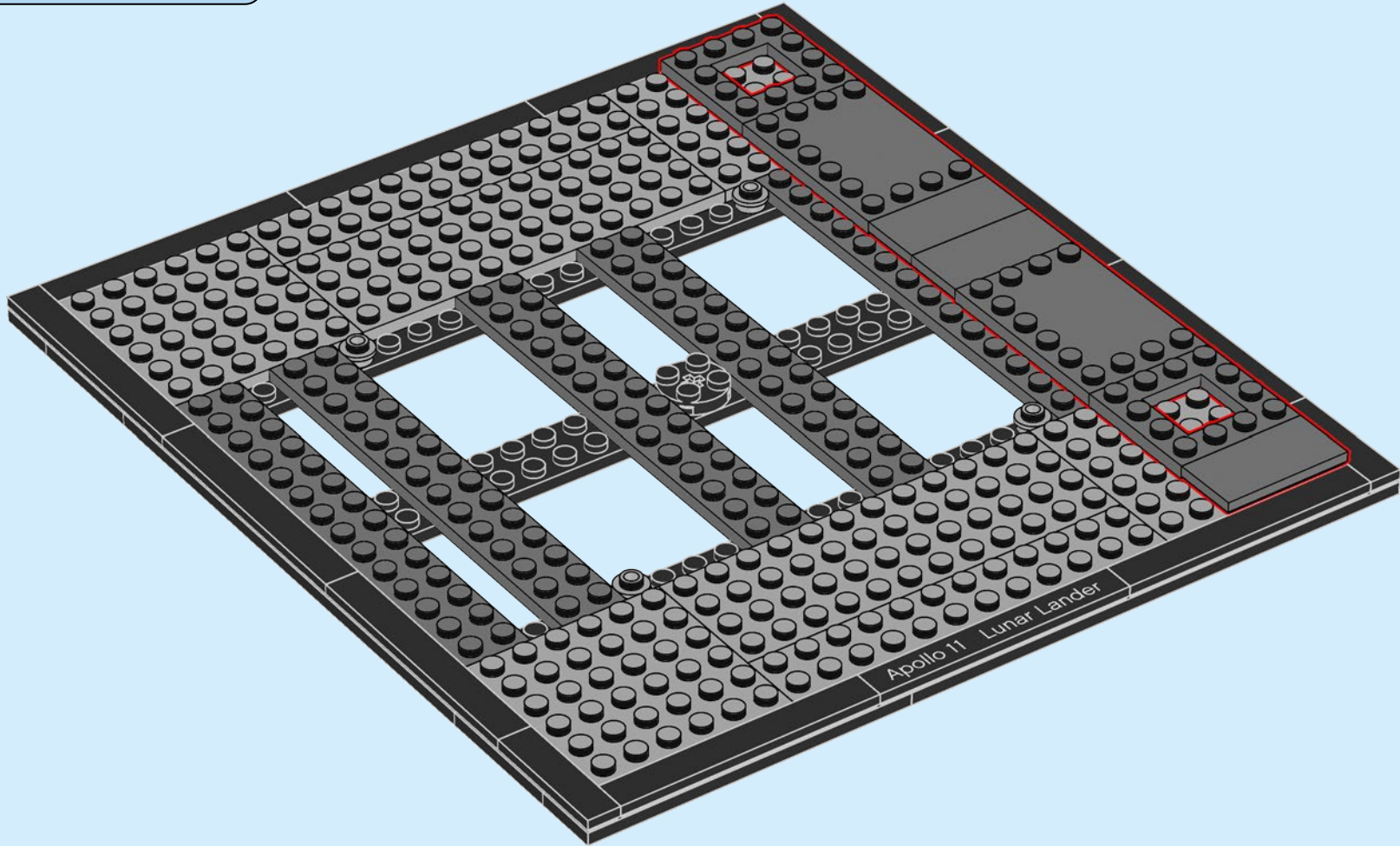



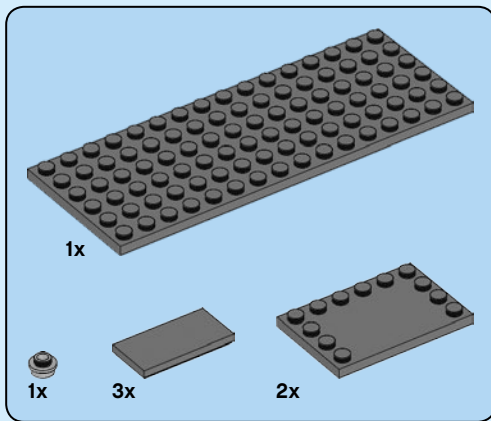

15

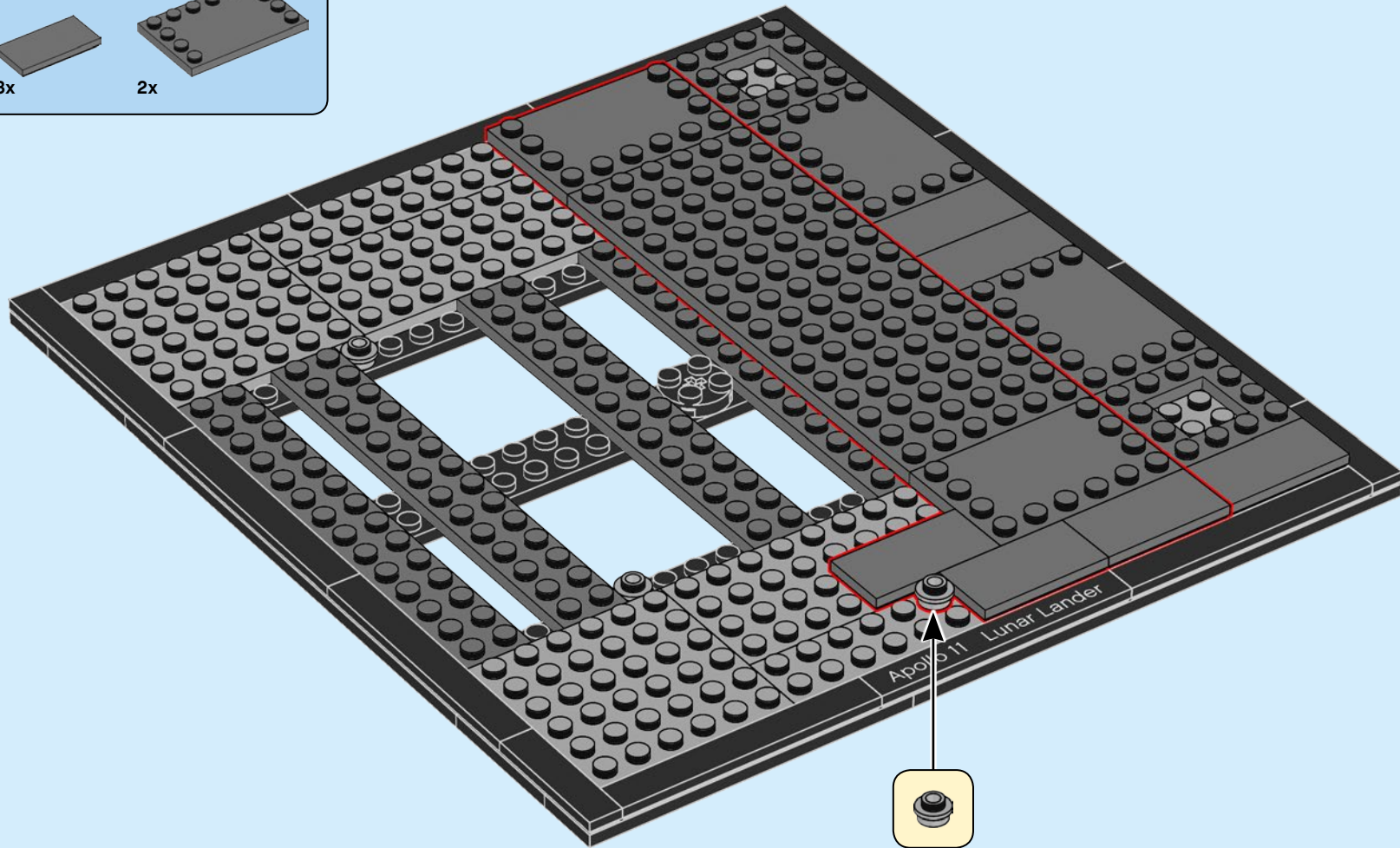

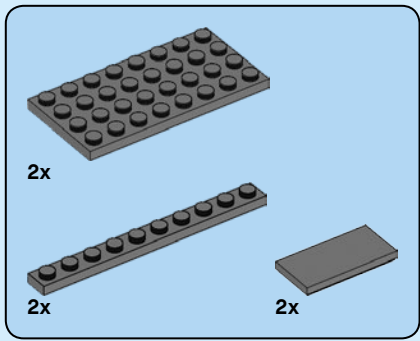

16

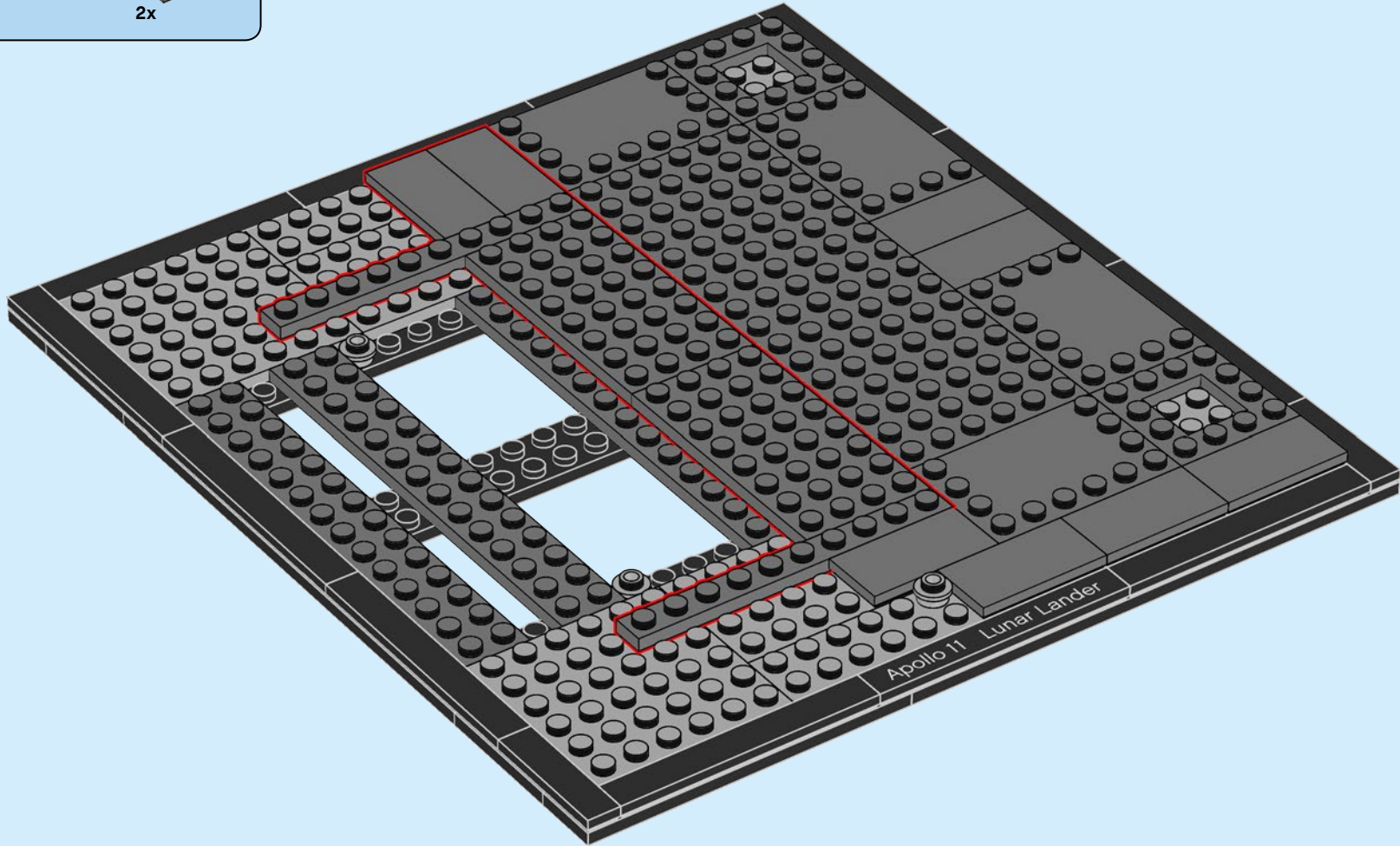



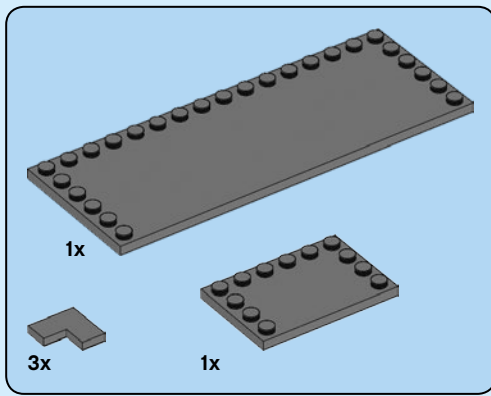

17

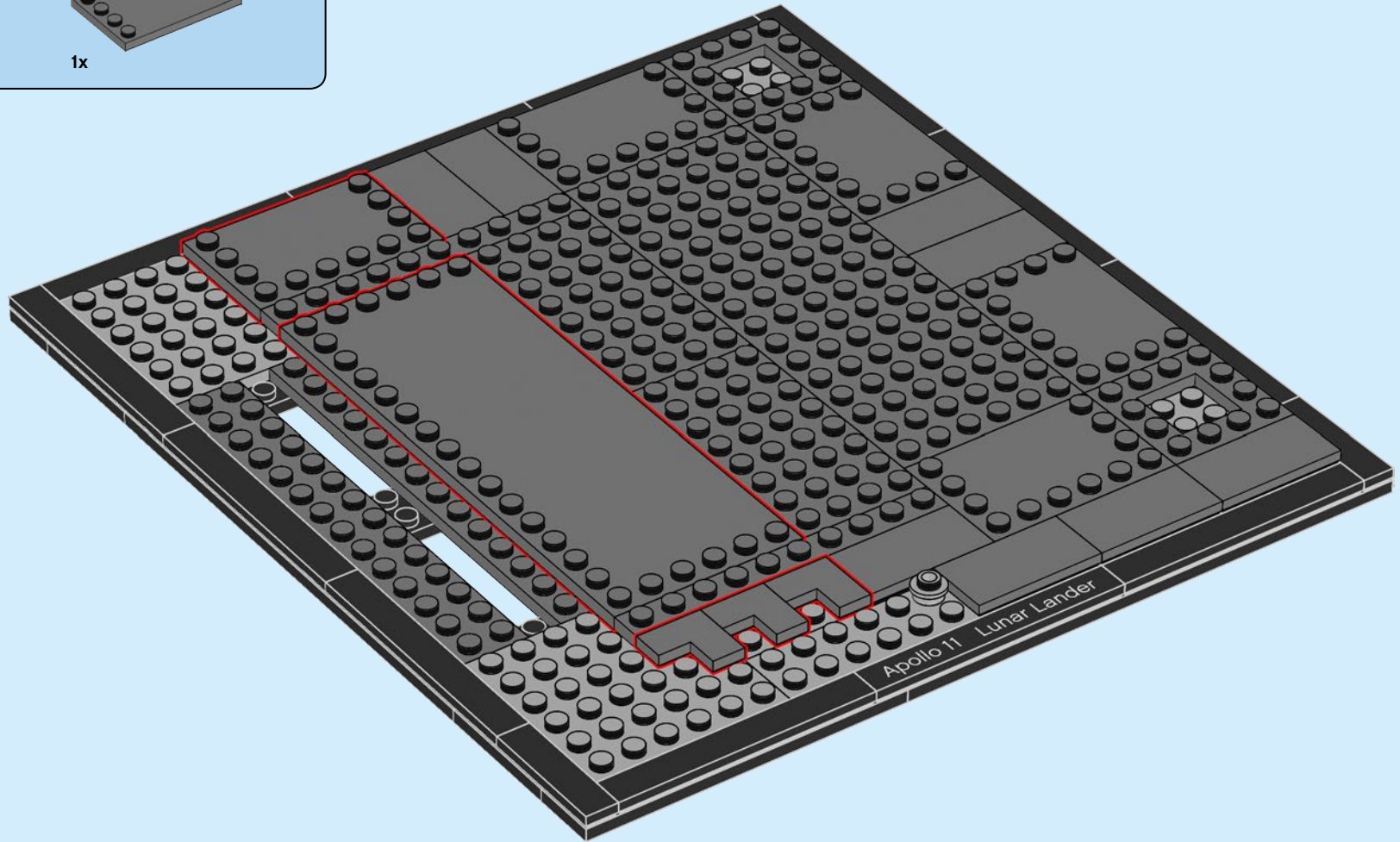

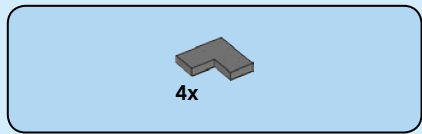

18

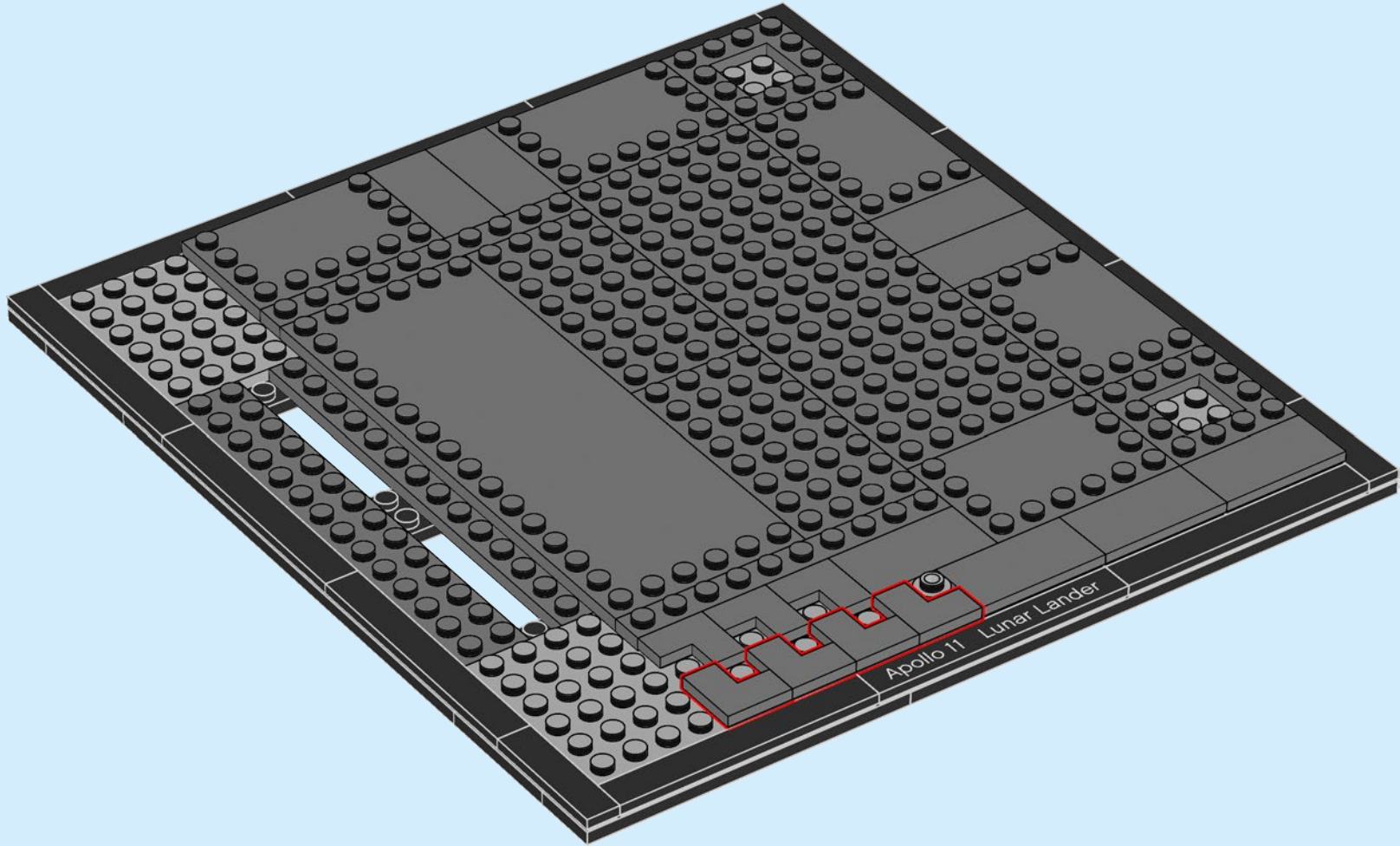



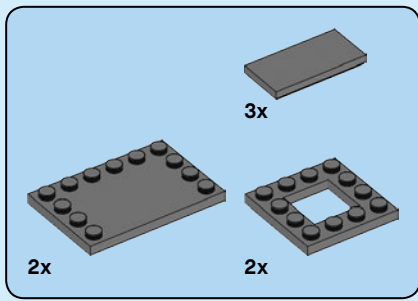

19

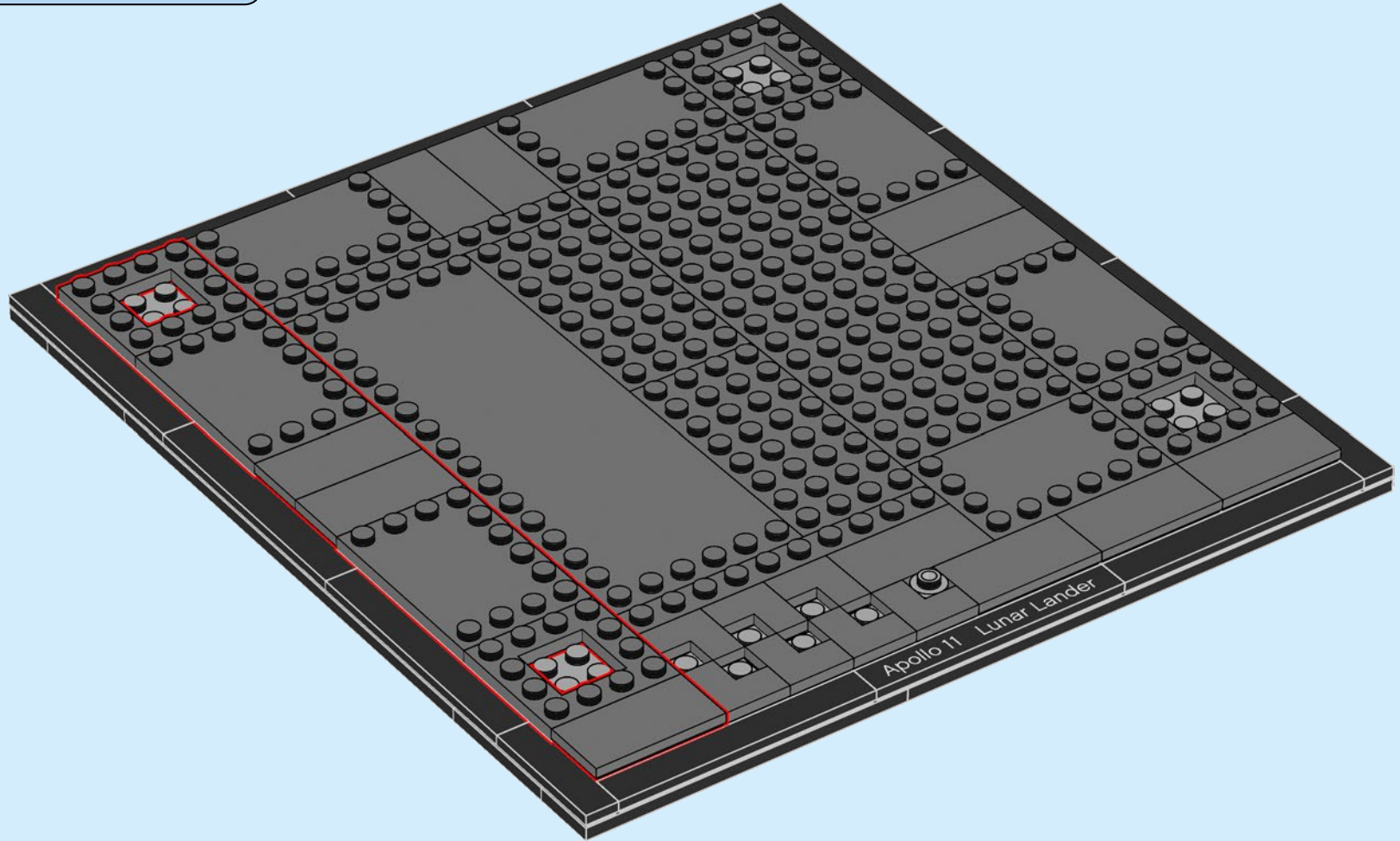



4x

20

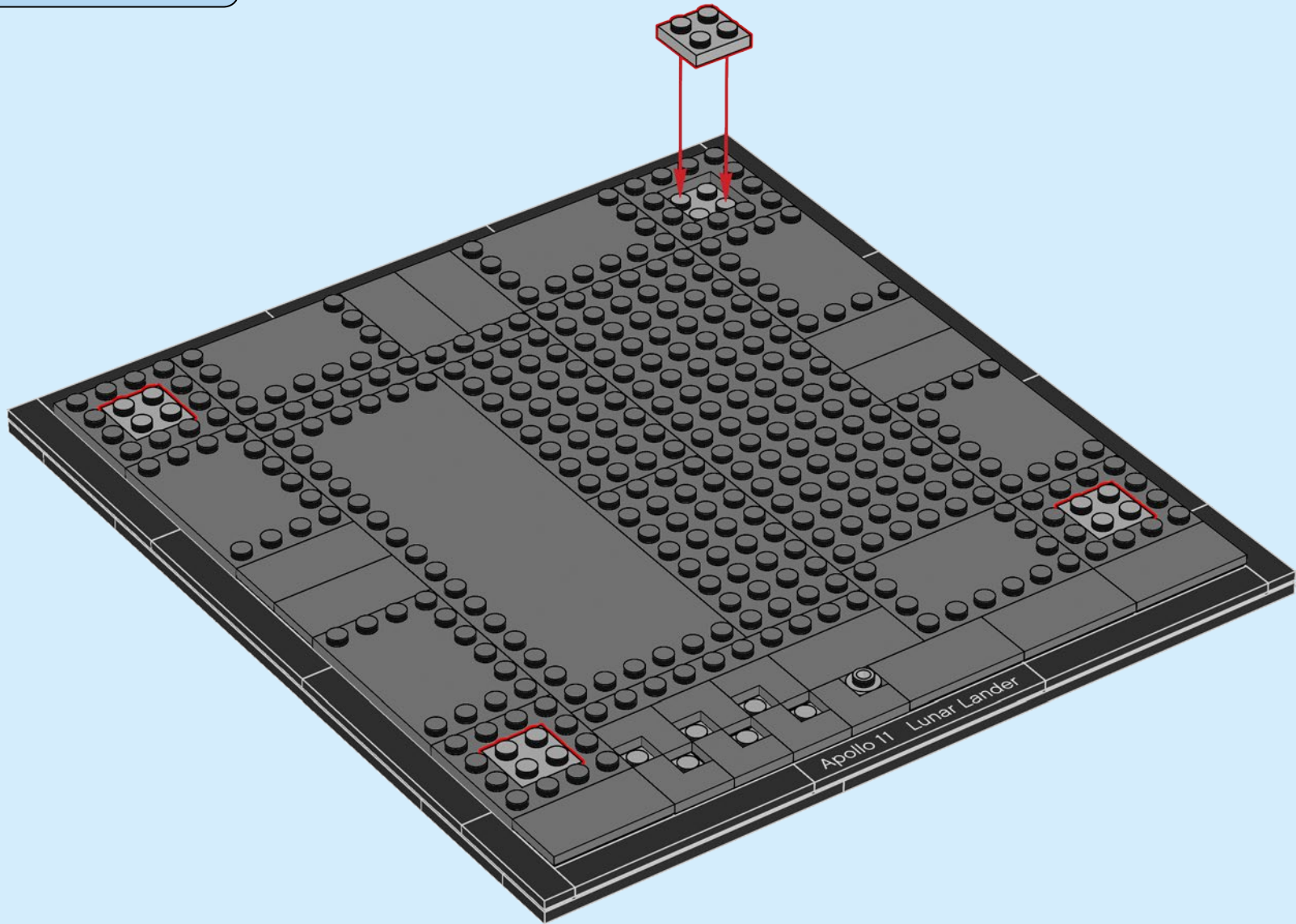



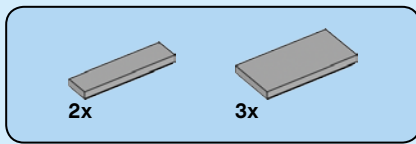

21

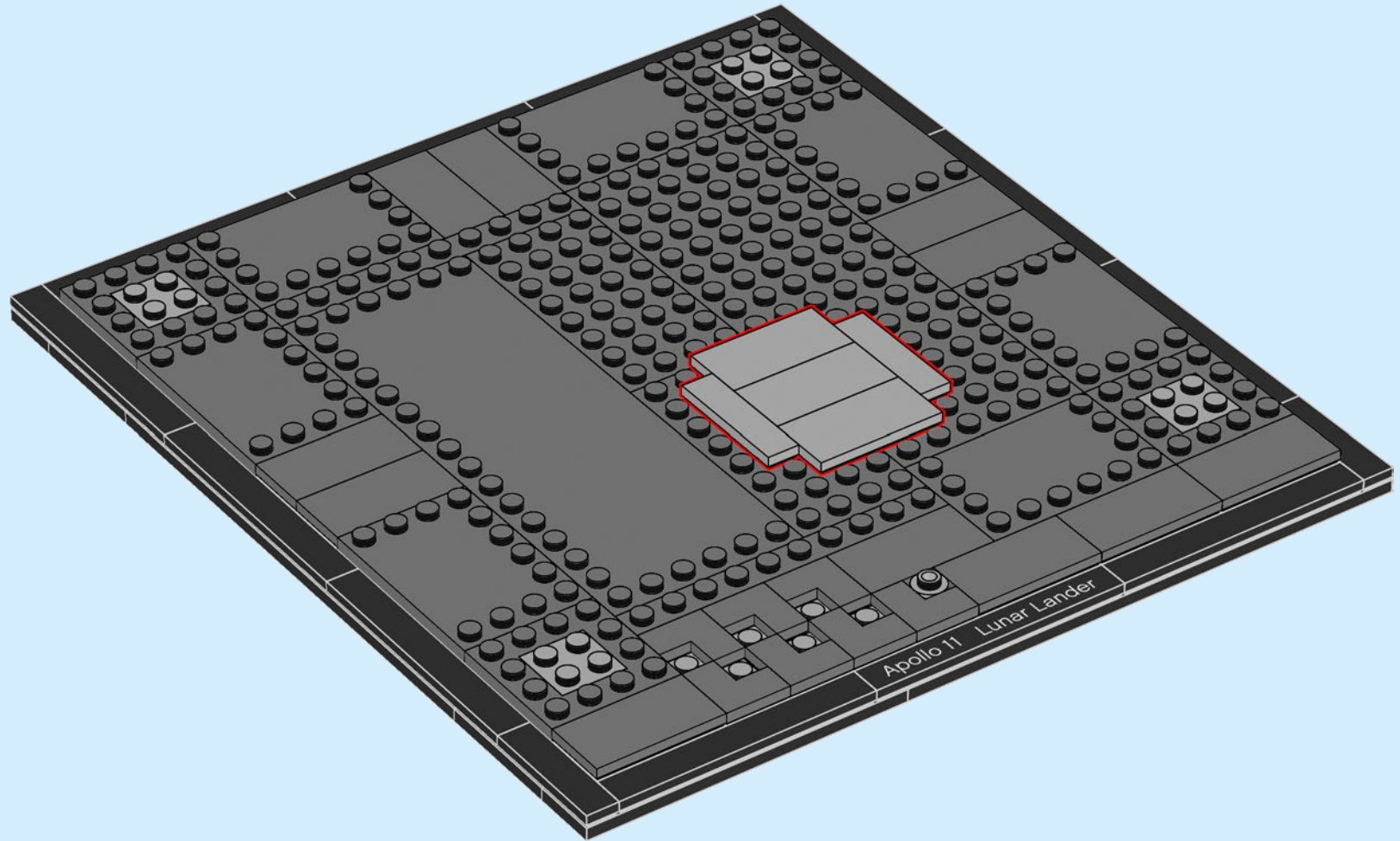

16x

3x

22

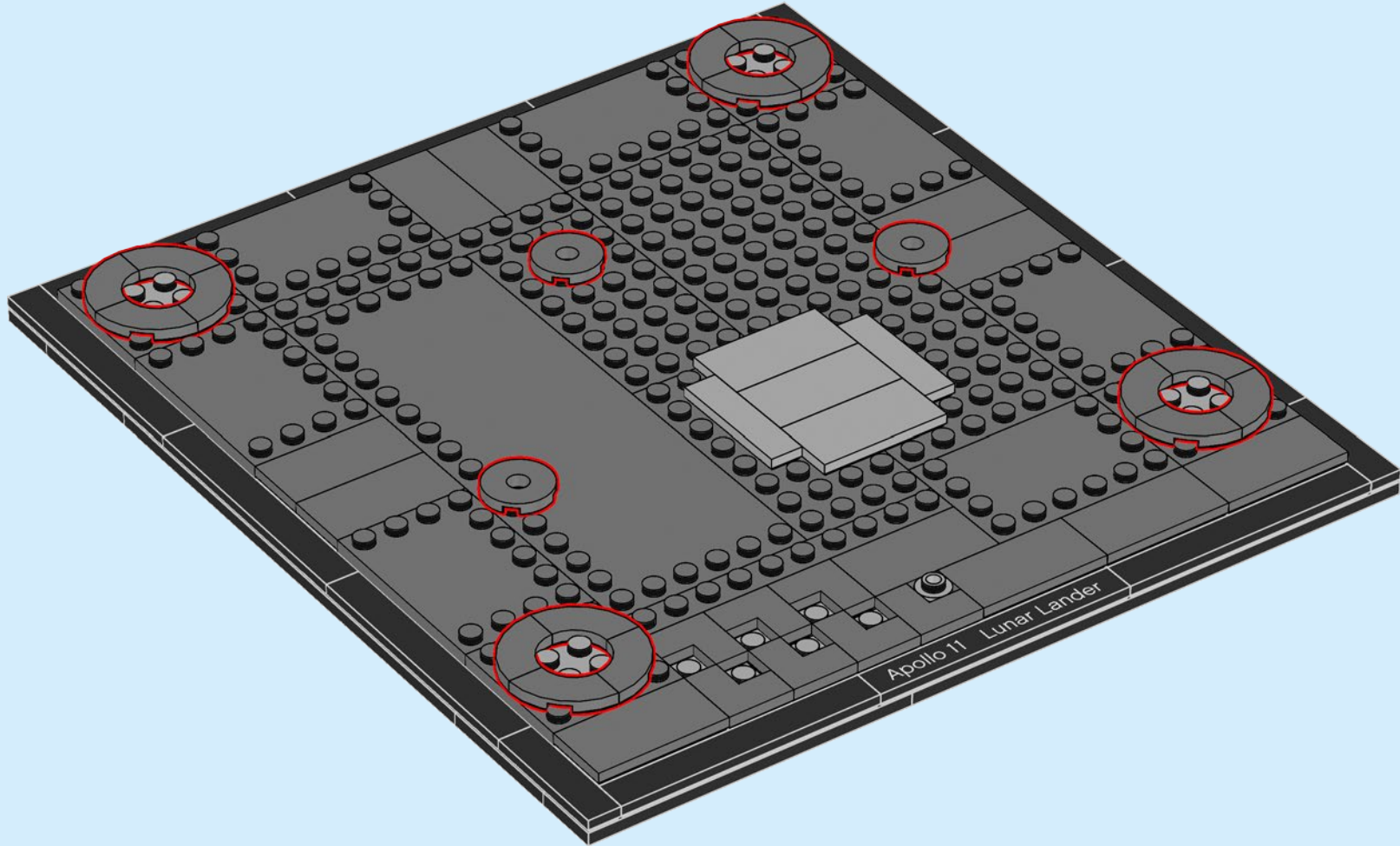



23

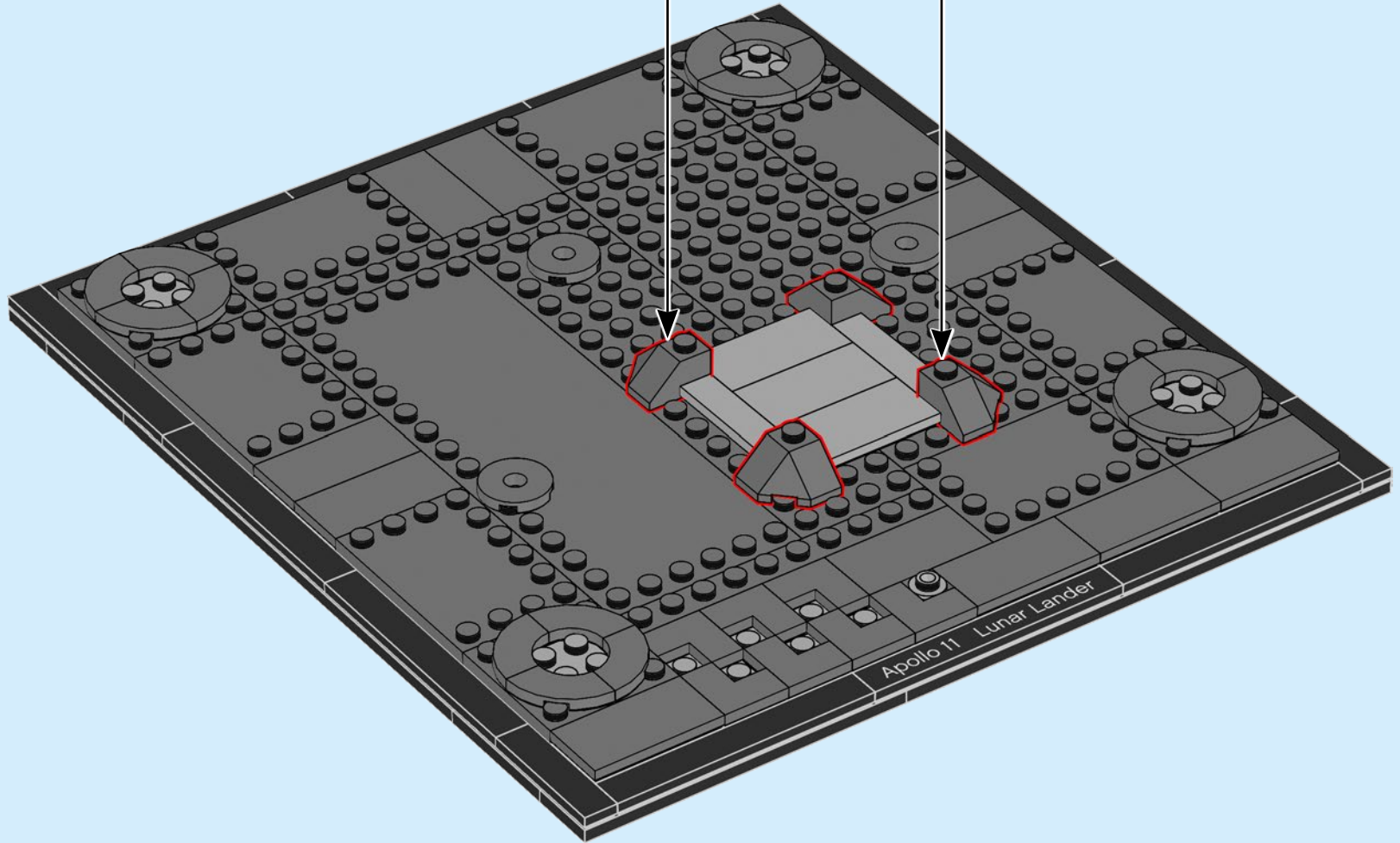



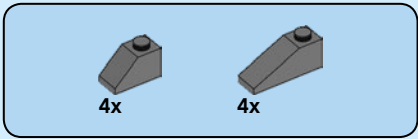

24

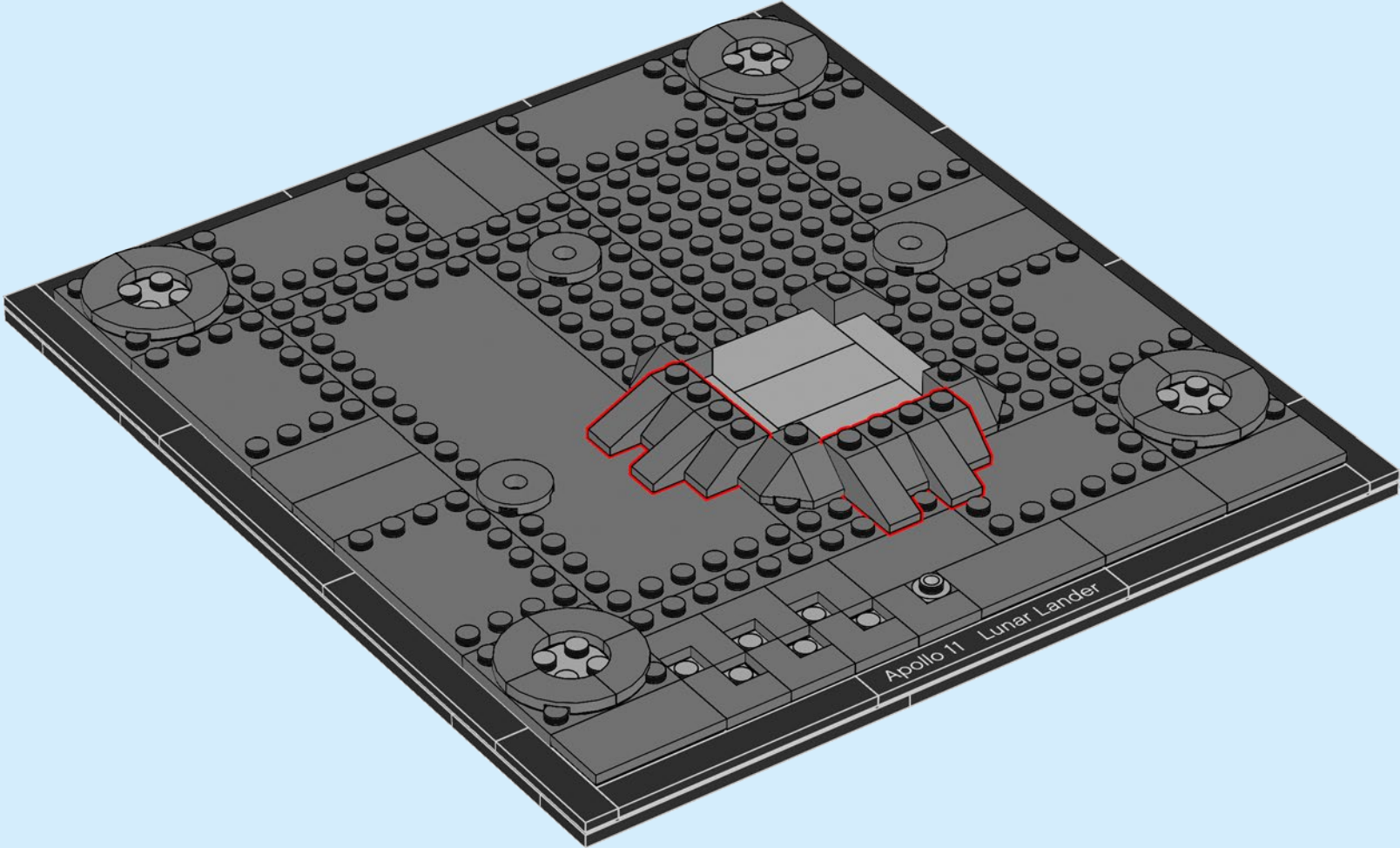

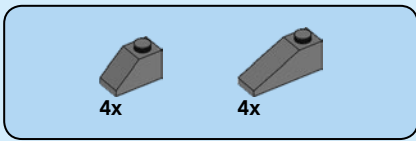

25

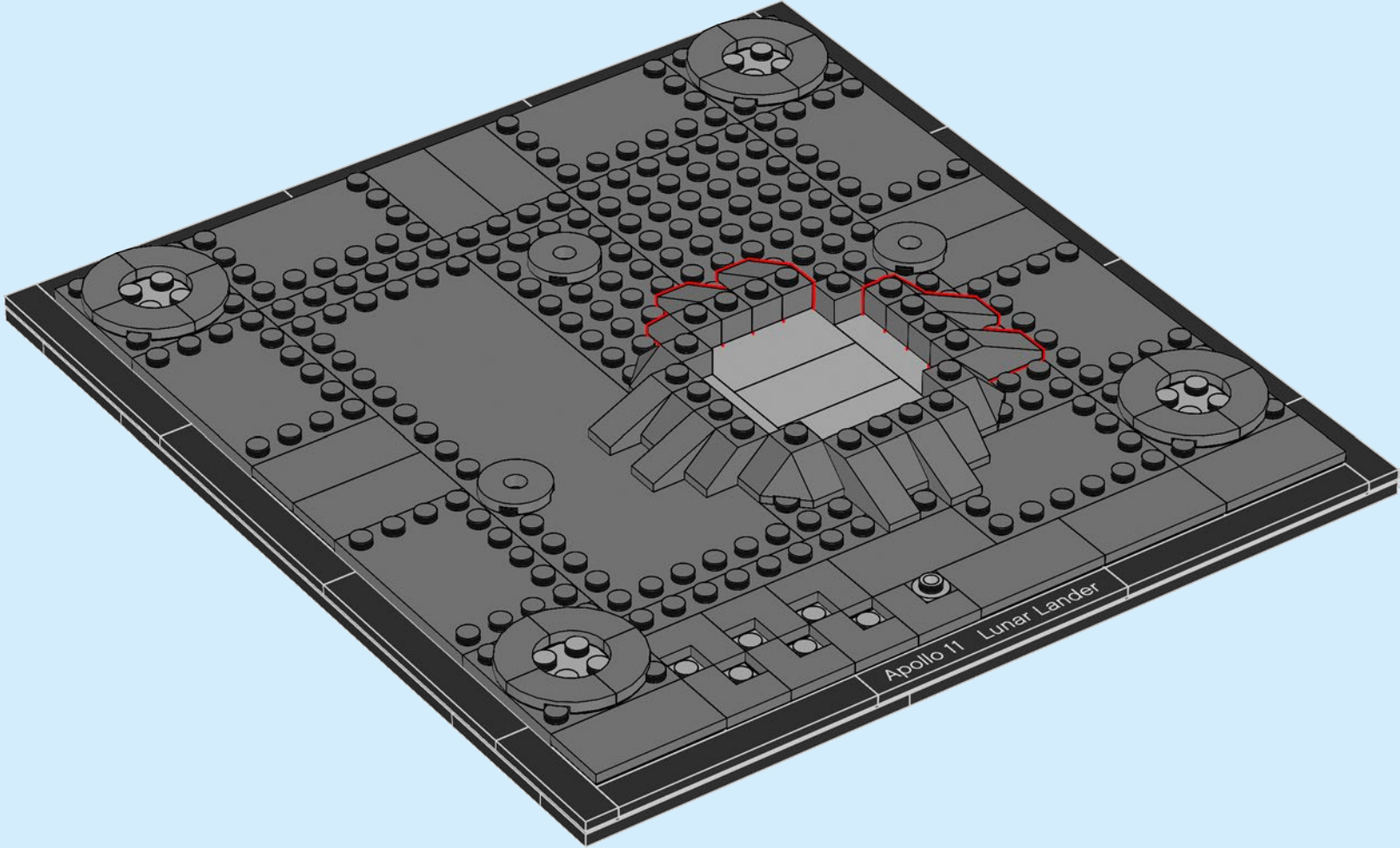



14x

26

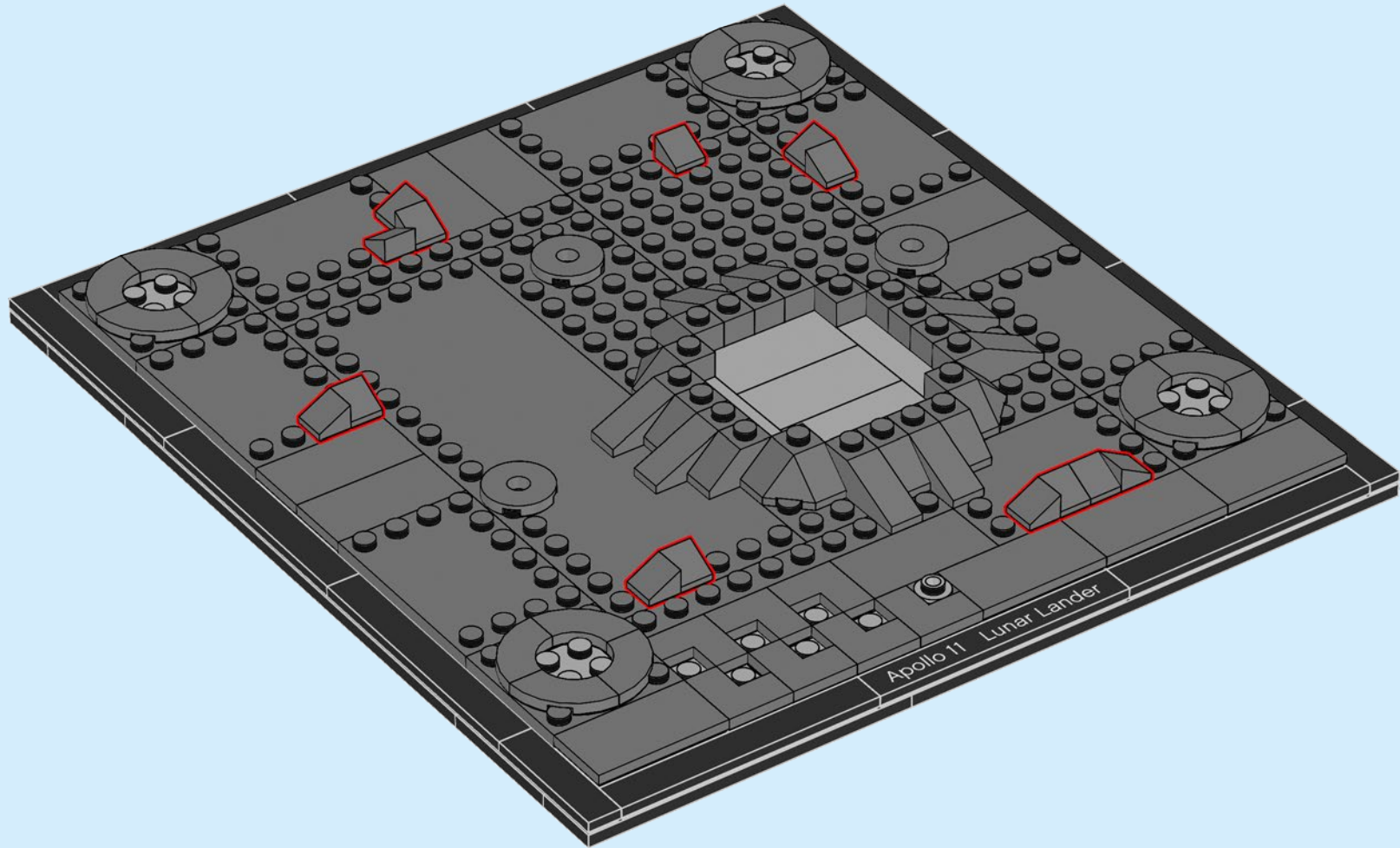



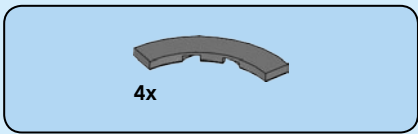

27

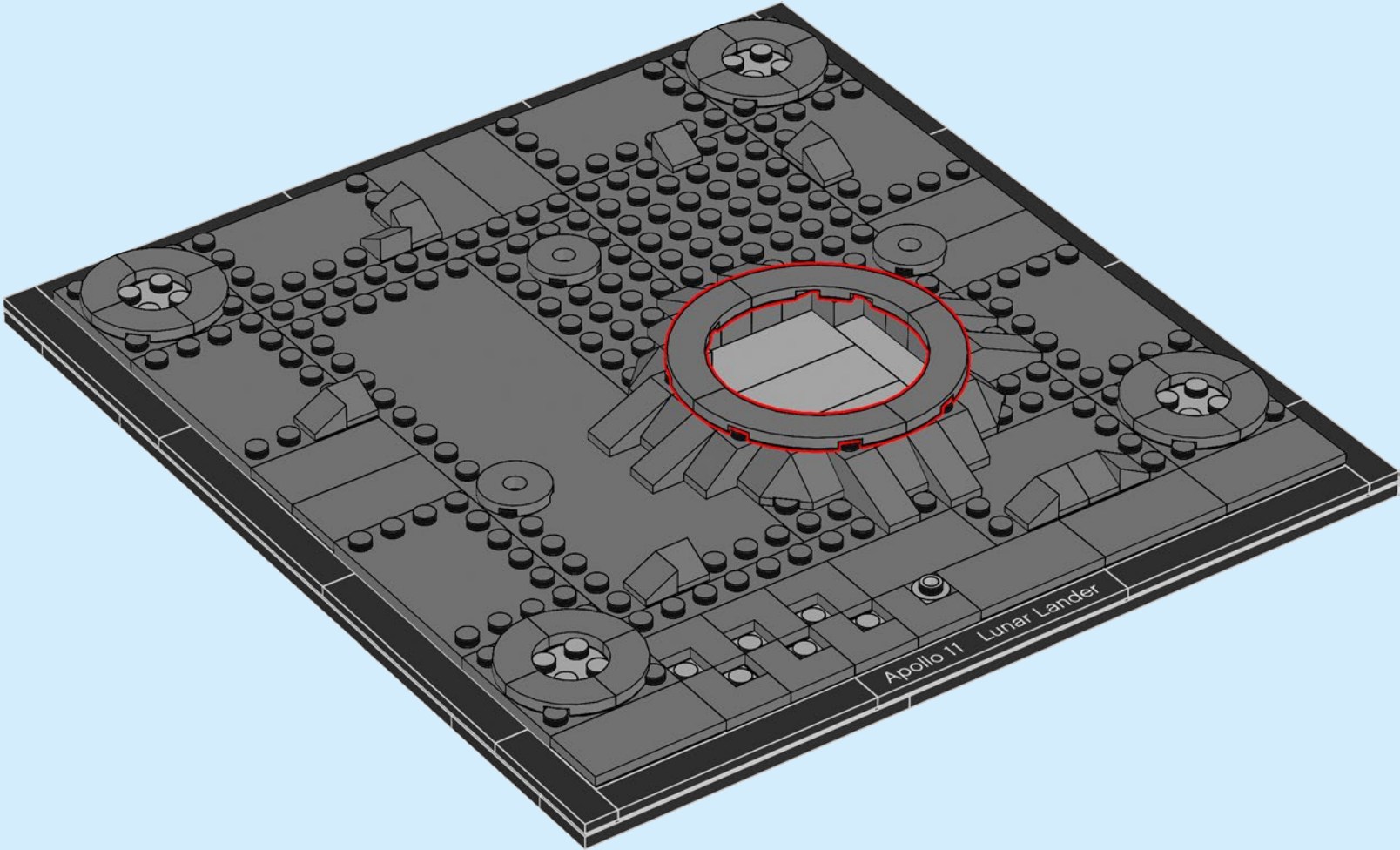

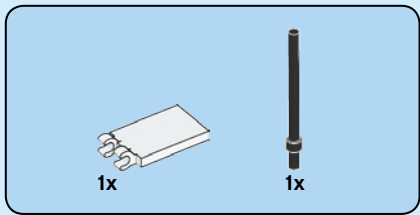

28

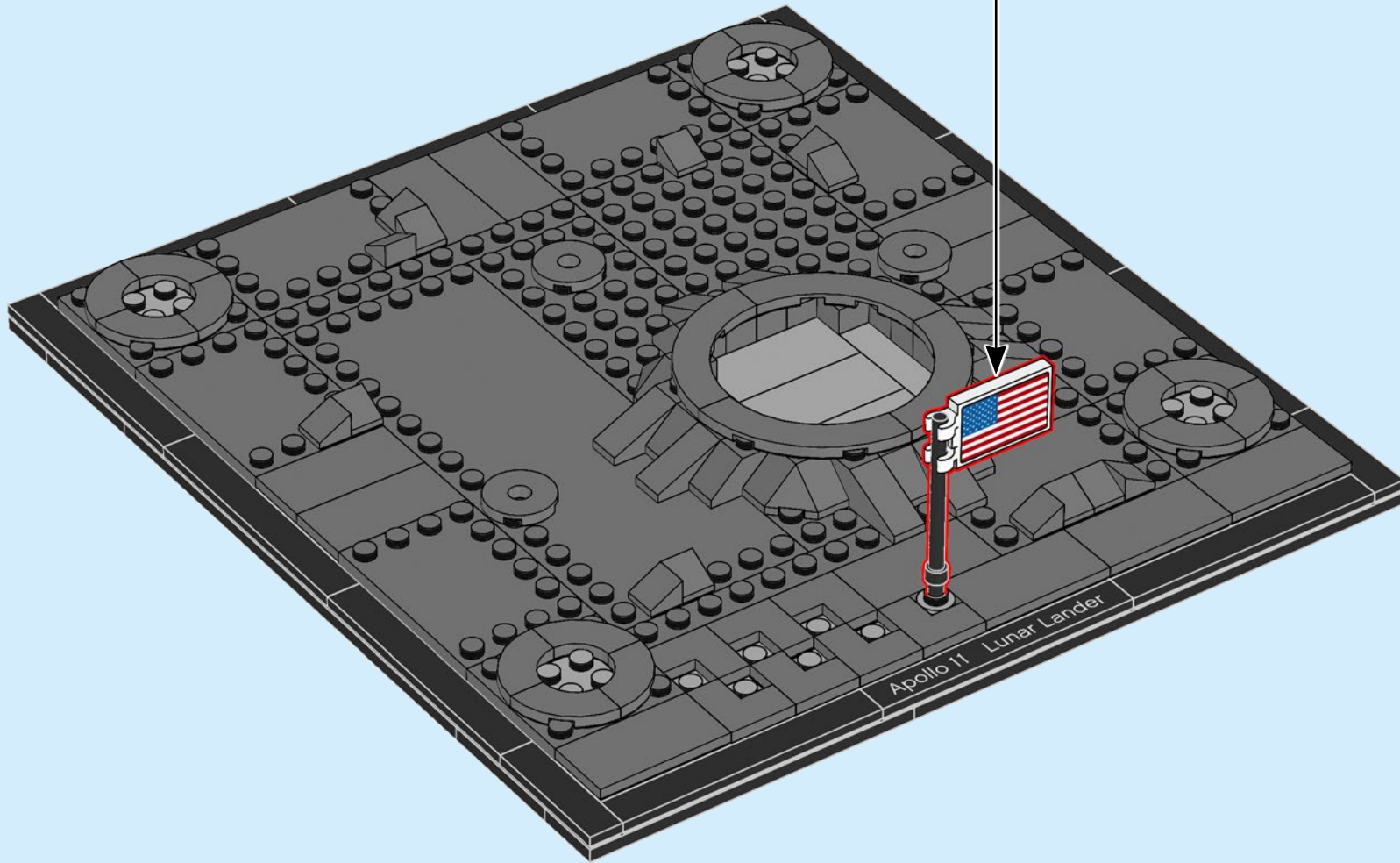
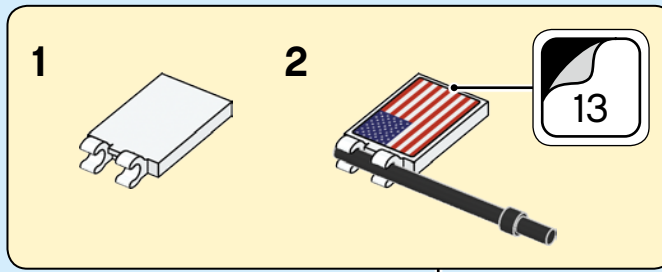

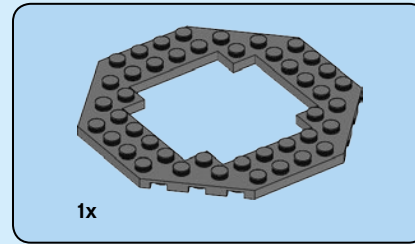
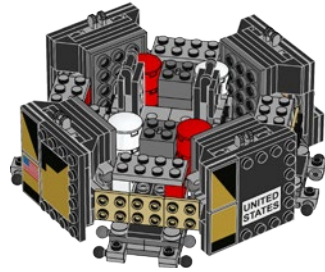
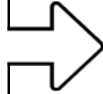

1

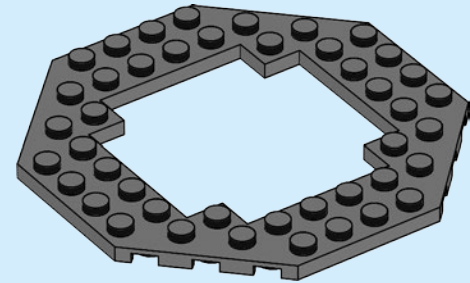
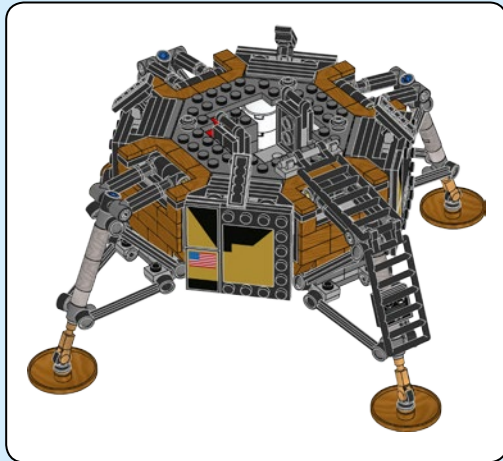



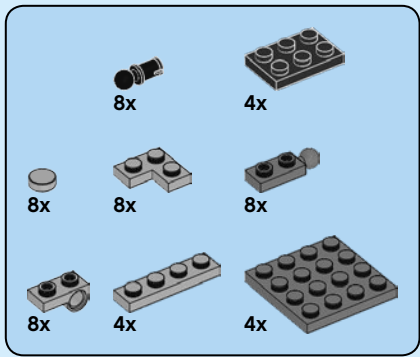

2

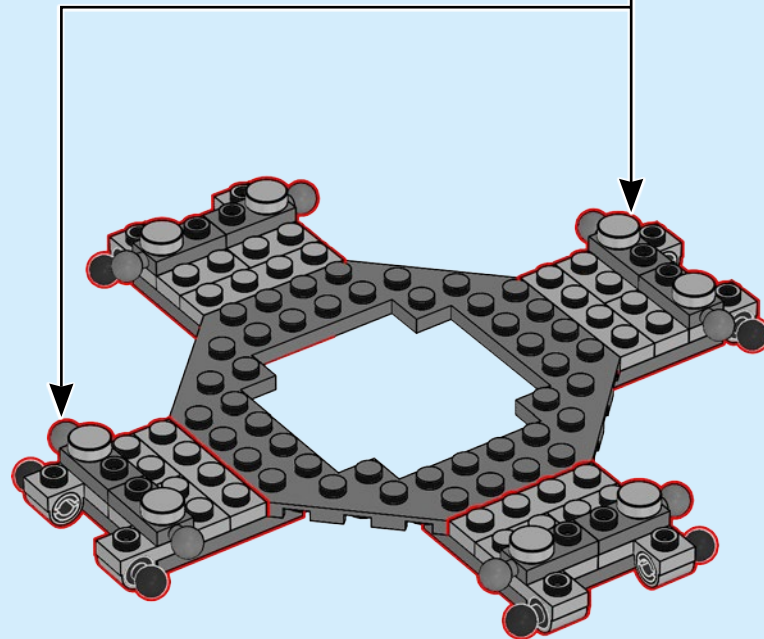
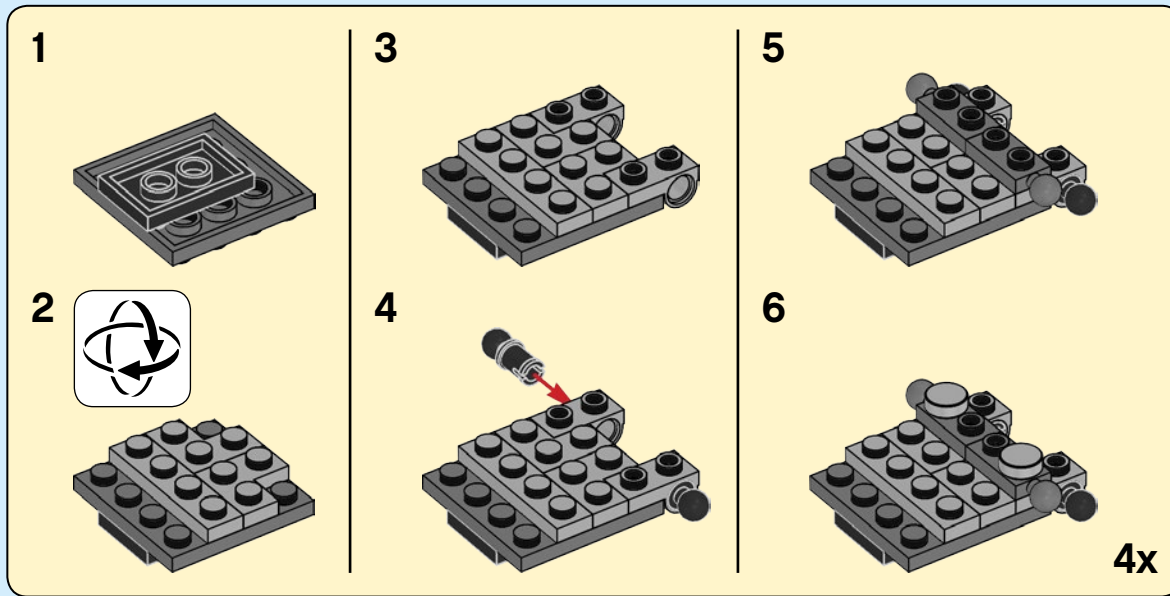

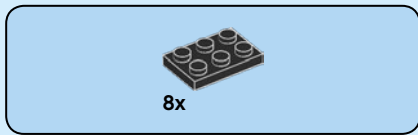

3

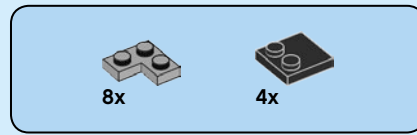
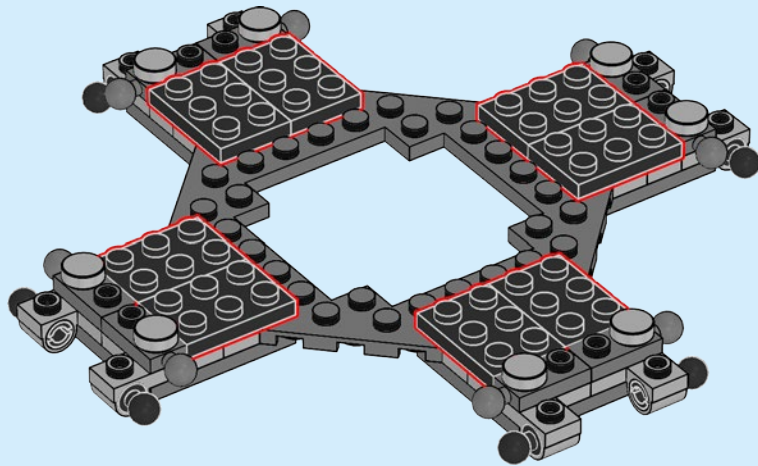

4

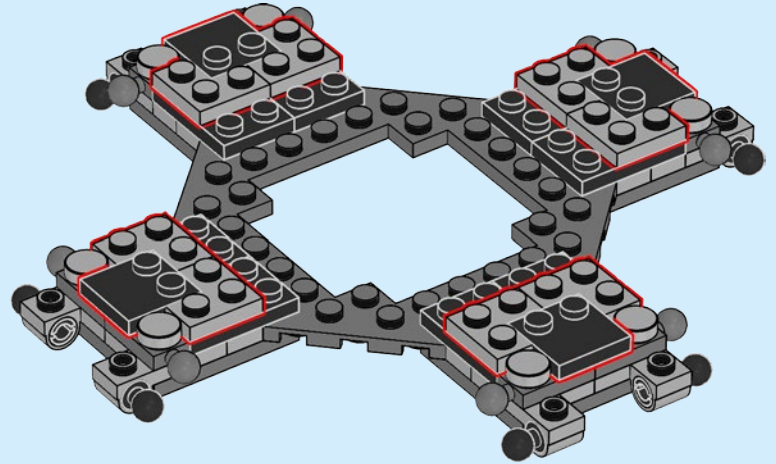

5

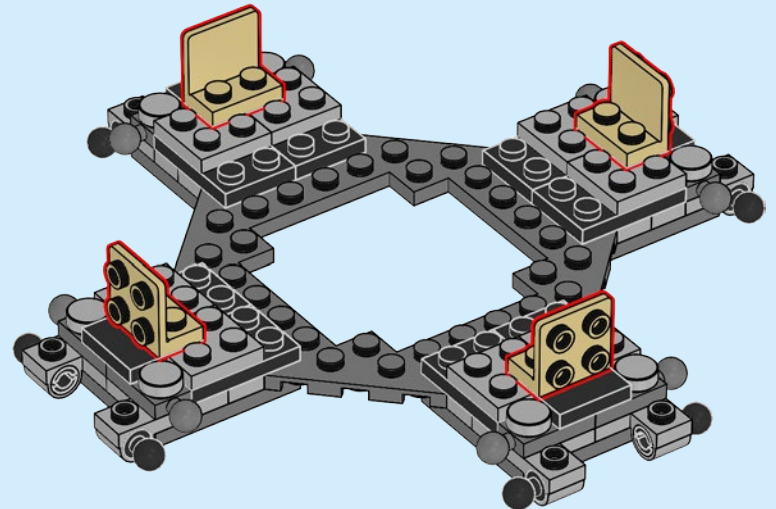

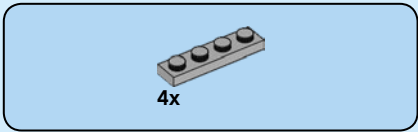

6

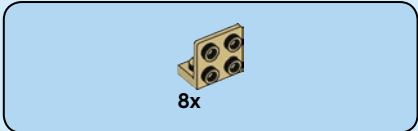
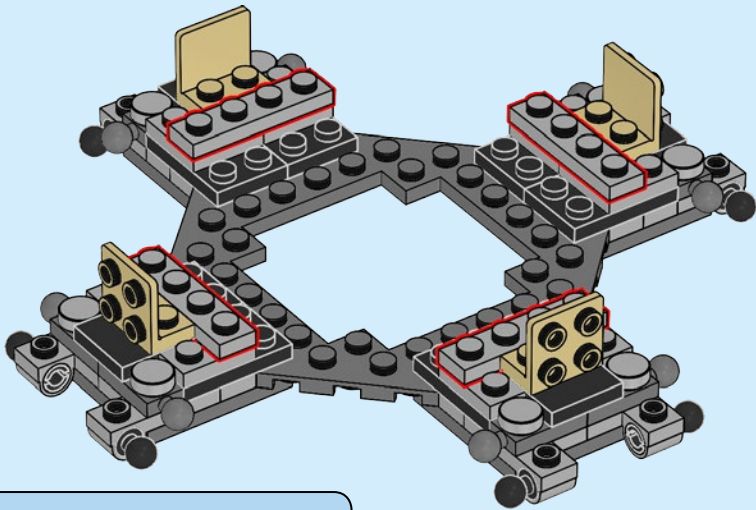

7

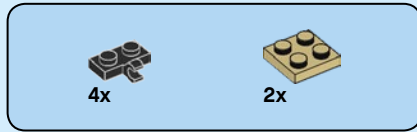
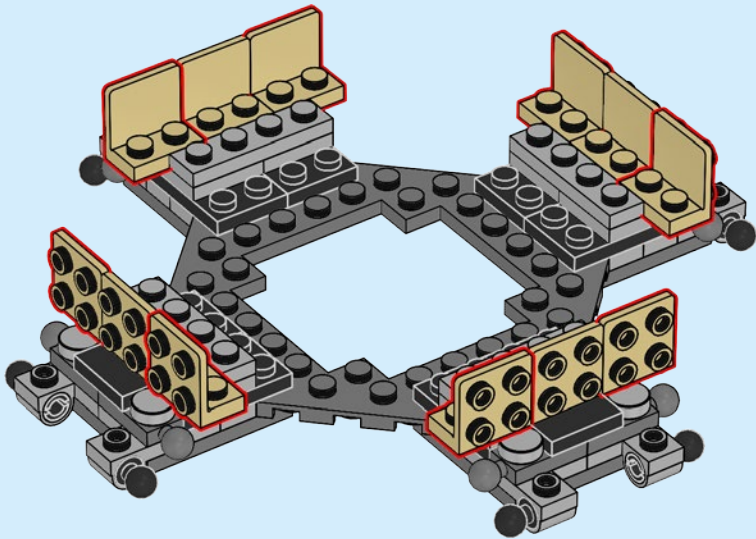

8

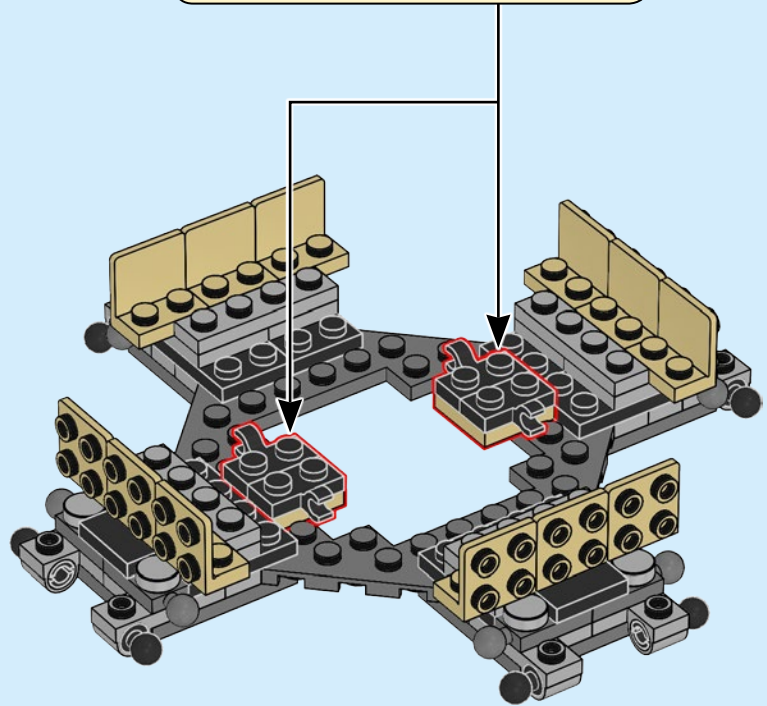
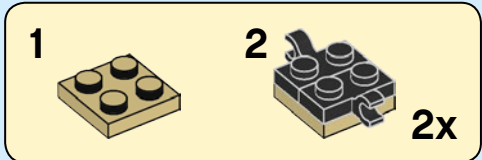



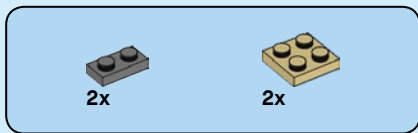

9

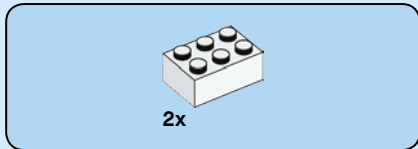
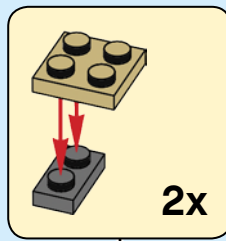
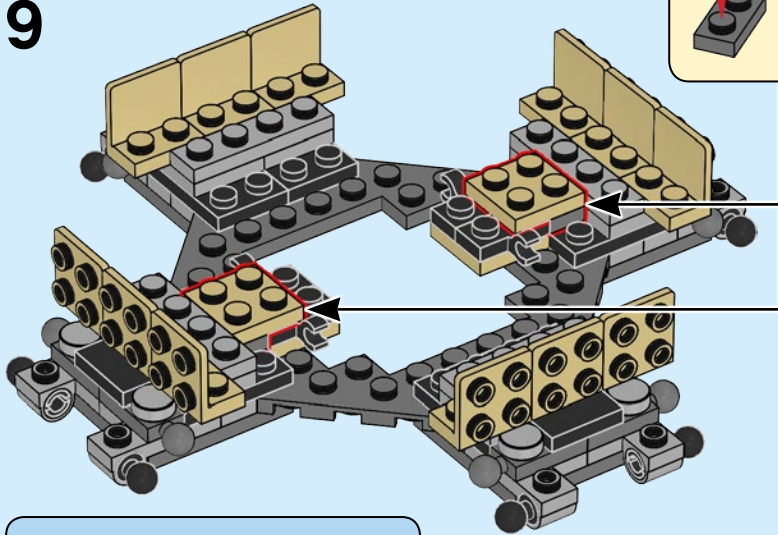

10

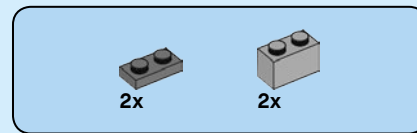
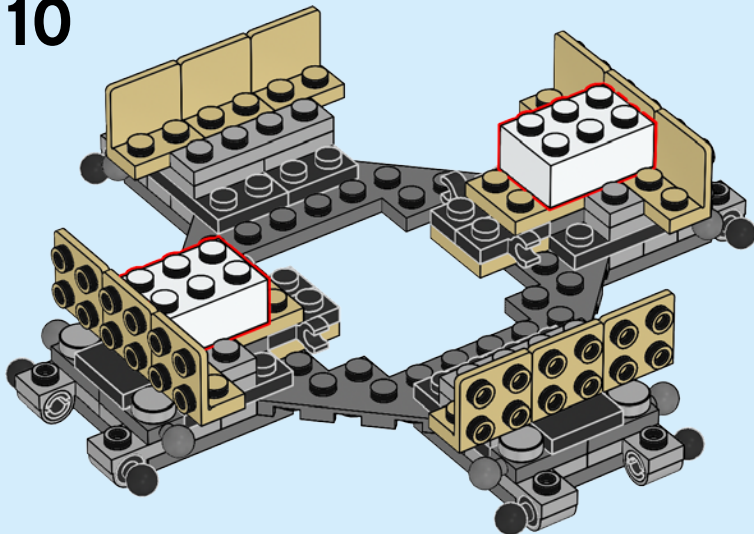

11

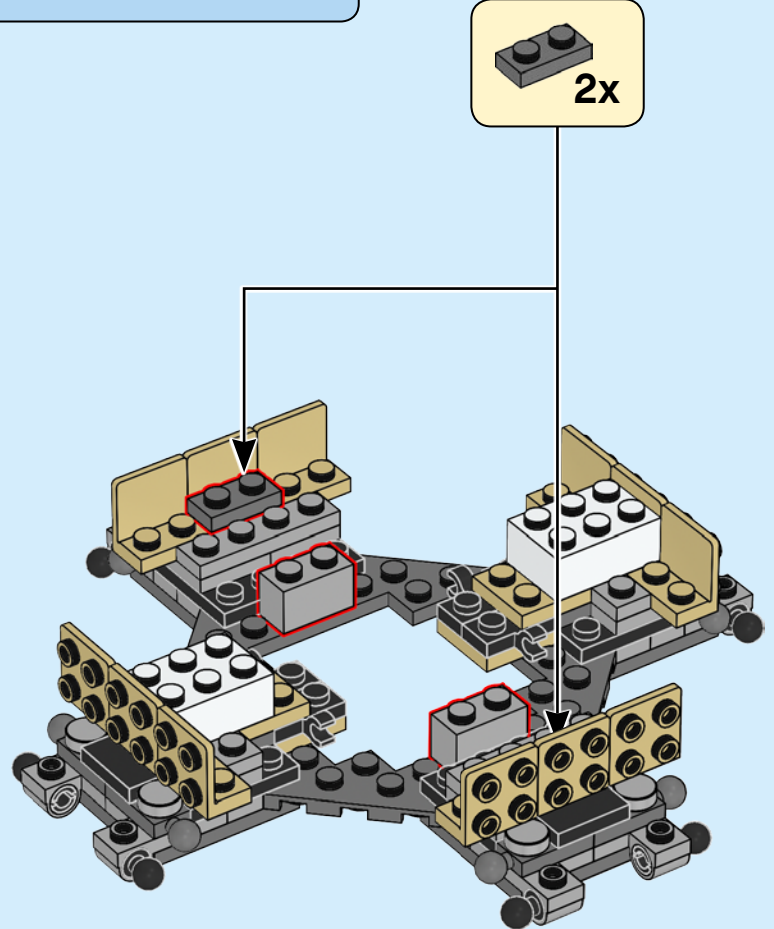

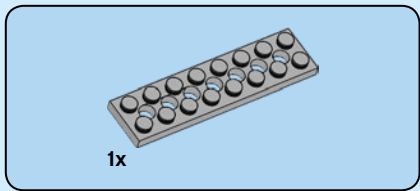

12

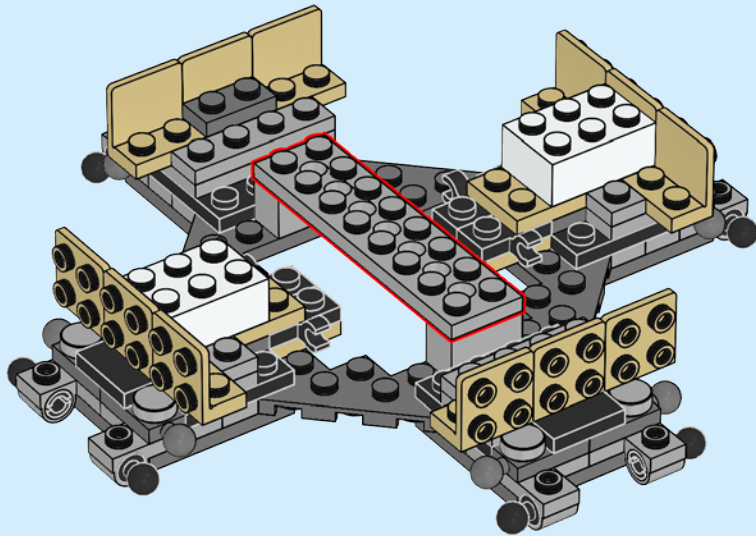

13

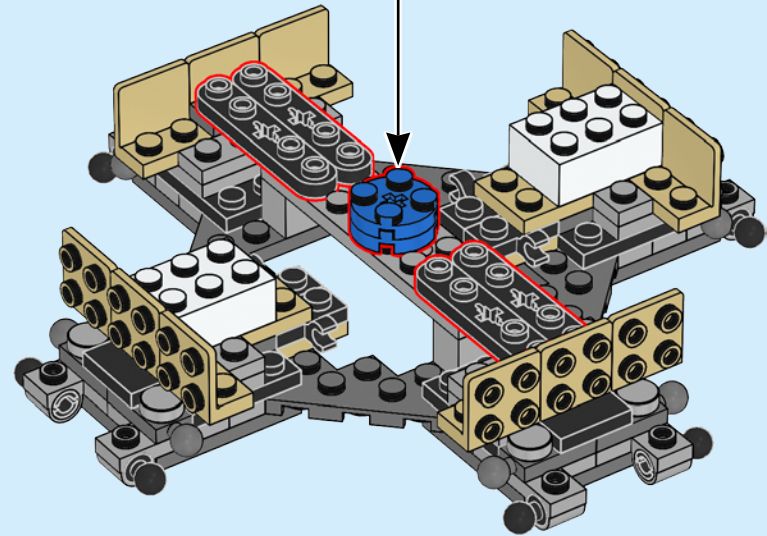
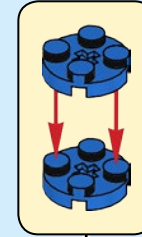

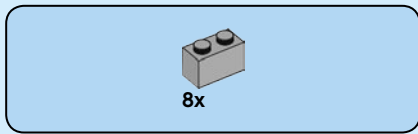

14

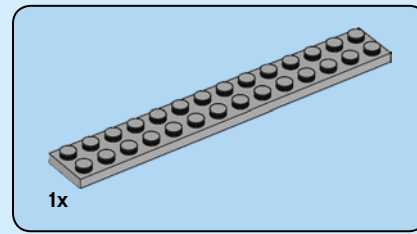
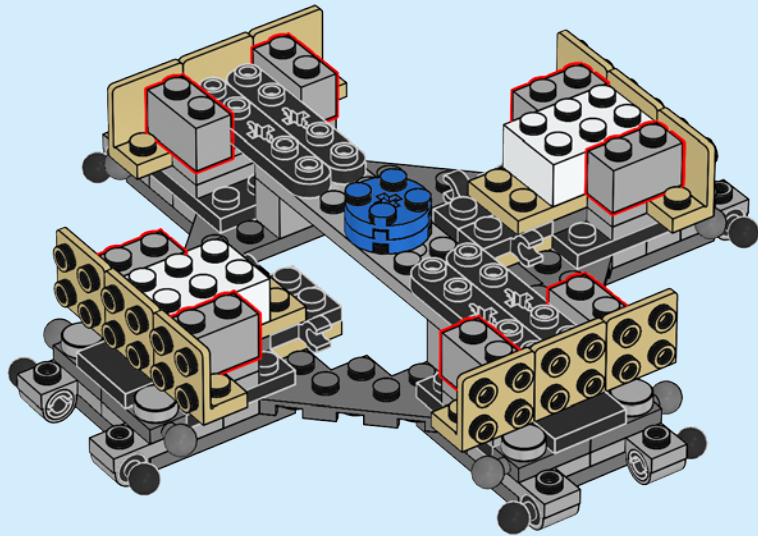

15

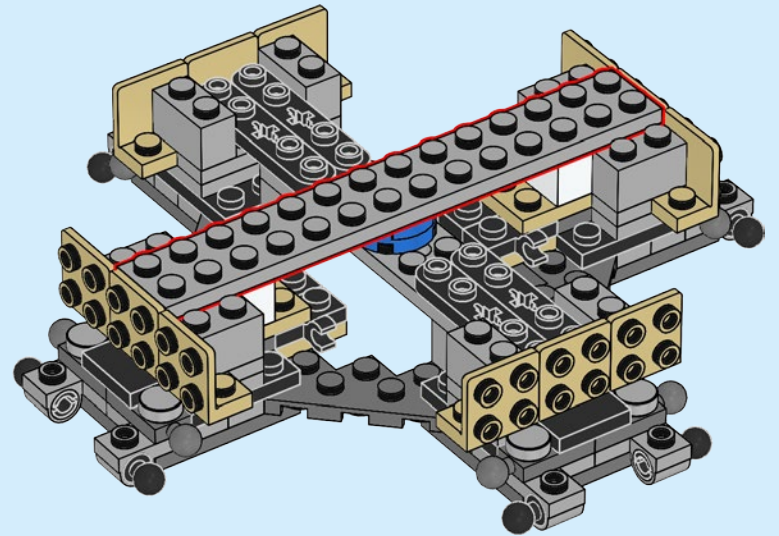



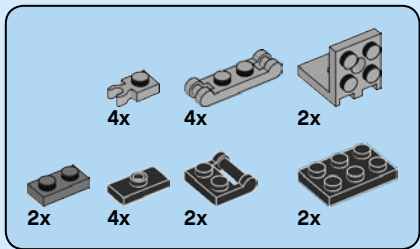

16

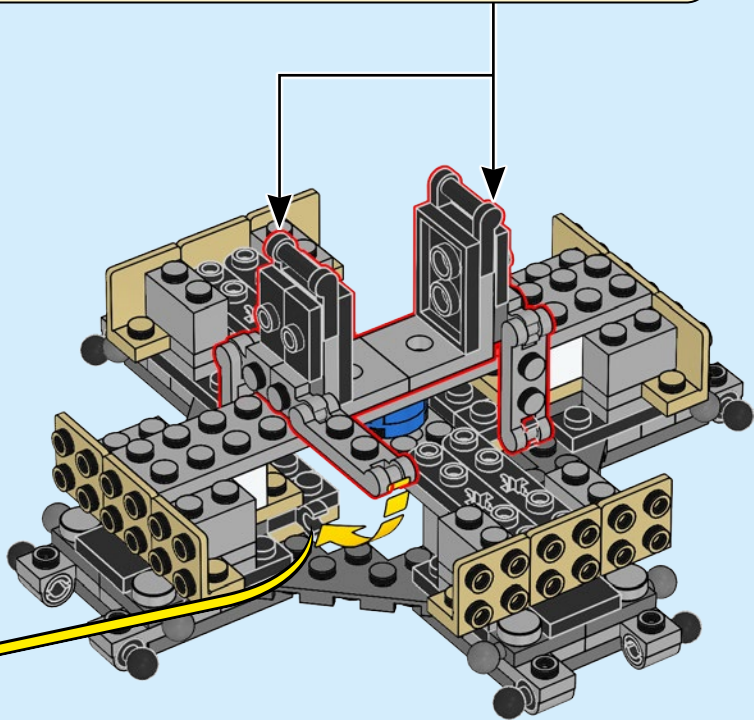
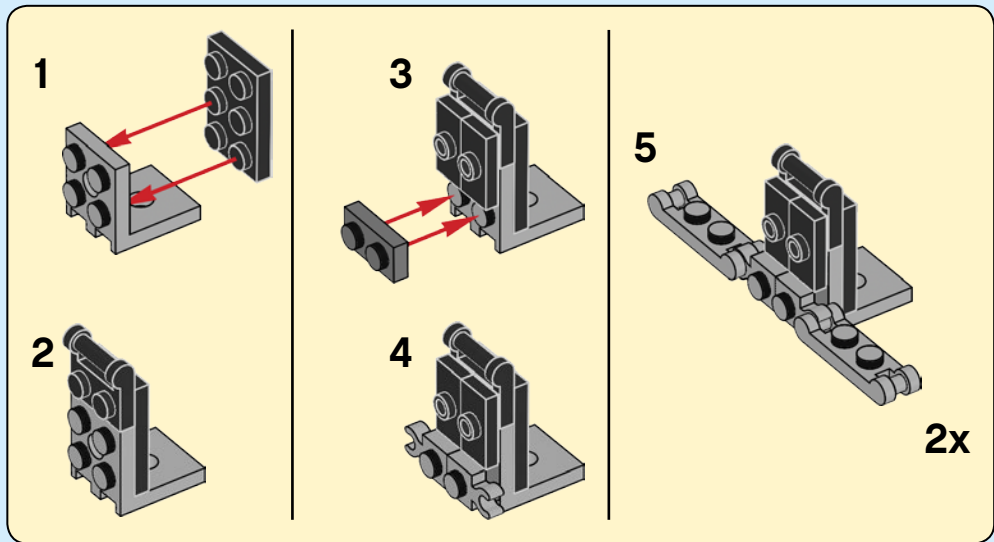

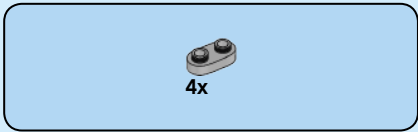

17

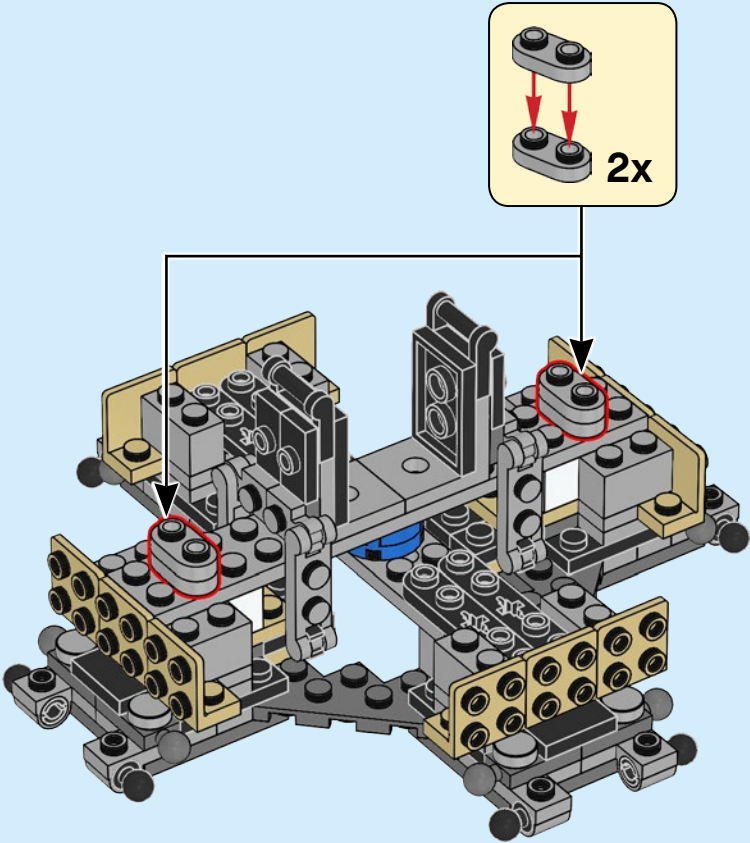

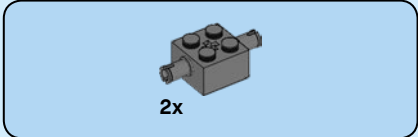
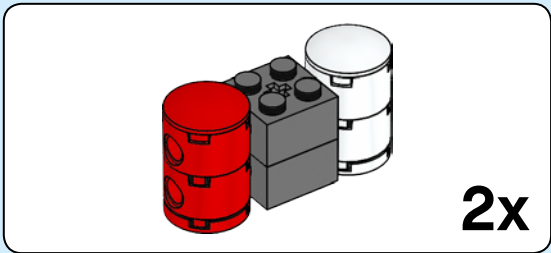

18

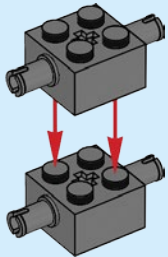

19

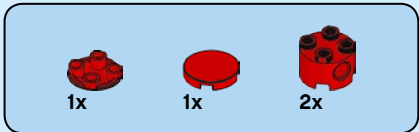
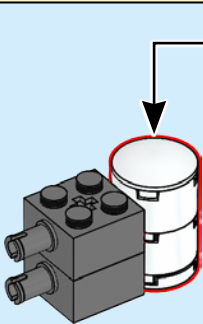
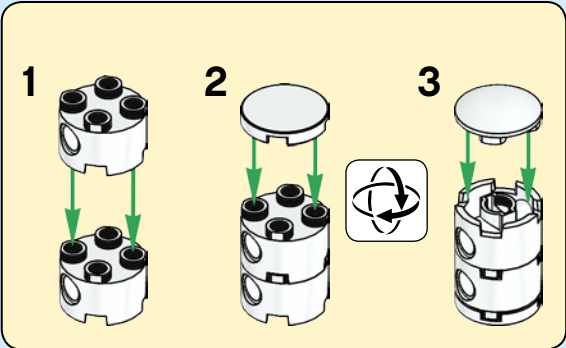

20

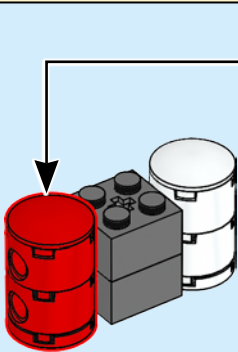
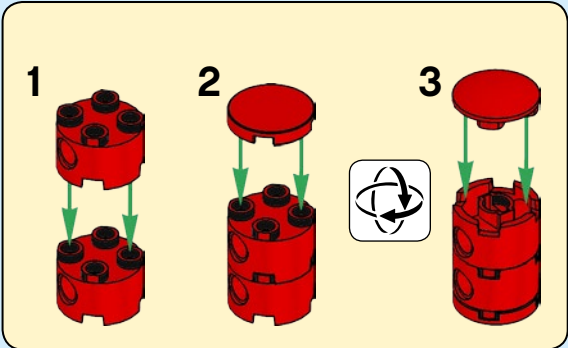

2x



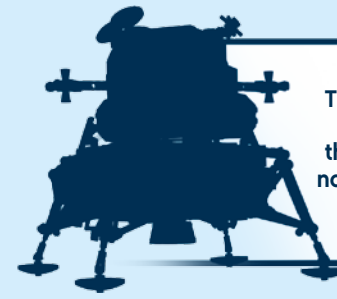

The Lunar Lander carried both fuel and an oxidizer to ignite the hypergolic fuels, since it is not possible to use fuel without an oxidizer in space.

21

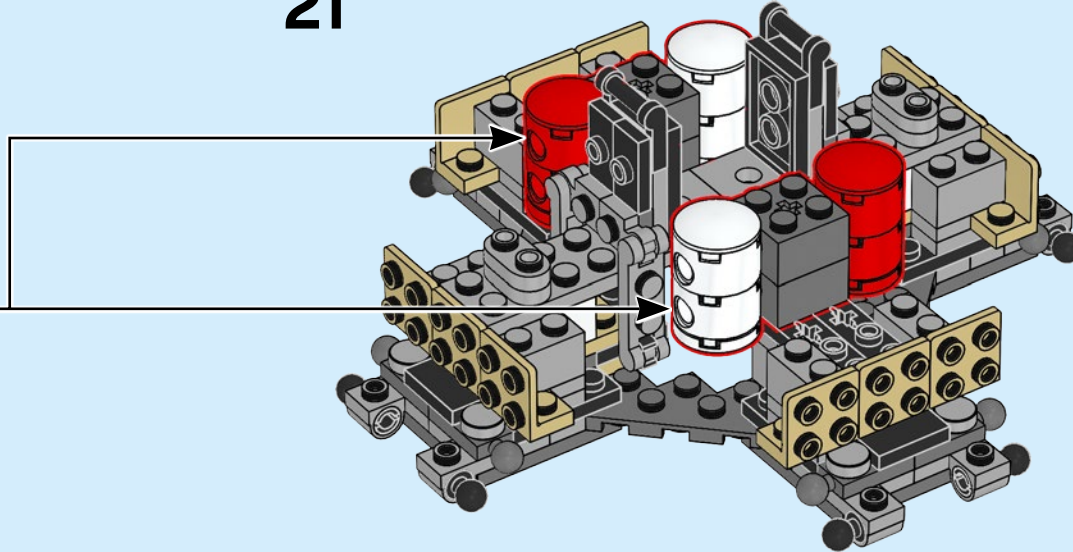

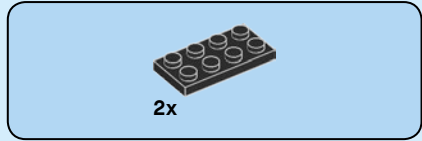

22

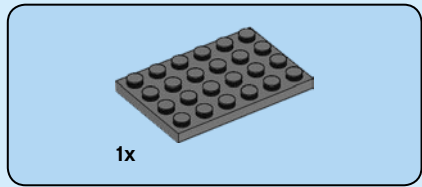
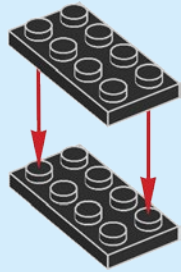

23

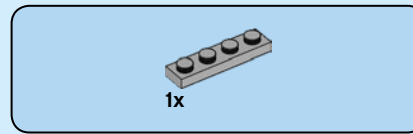
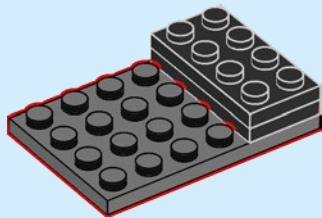

24

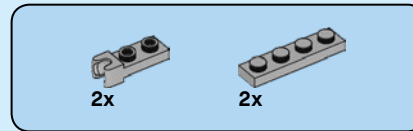
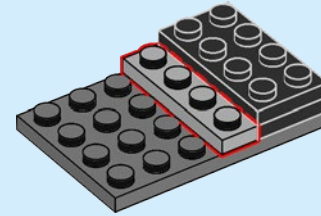

25

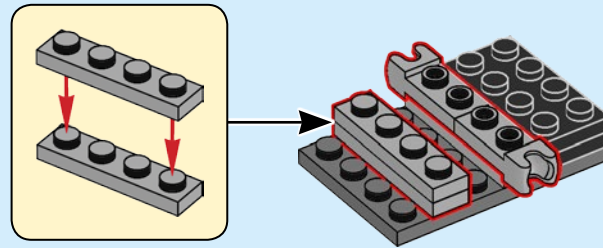

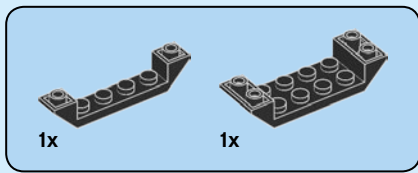

26

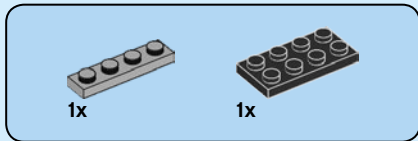
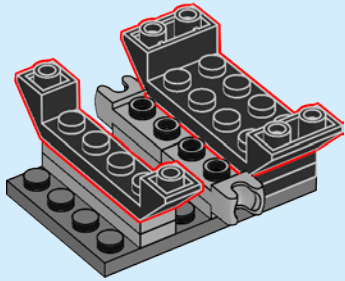

27

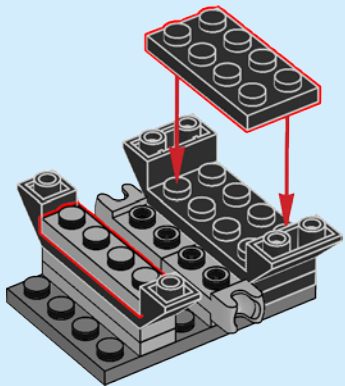

28

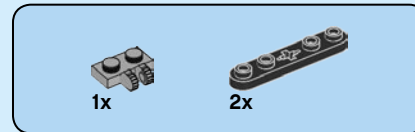
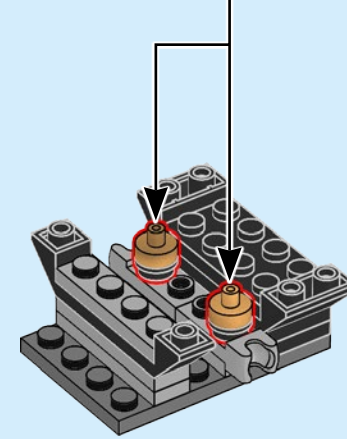
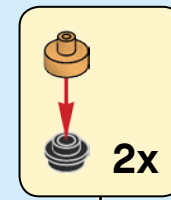

29

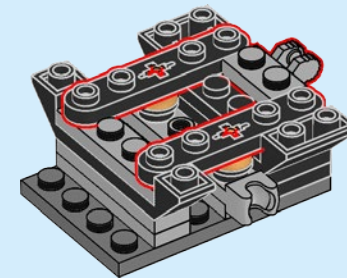



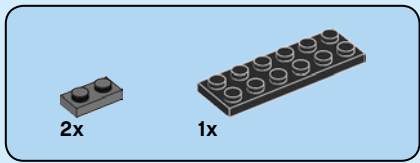

30

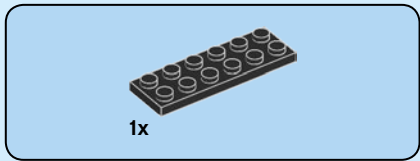
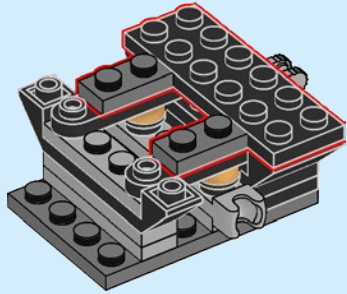

31

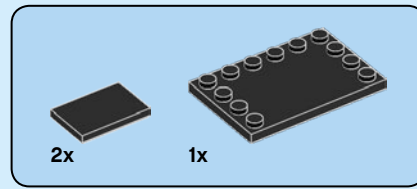
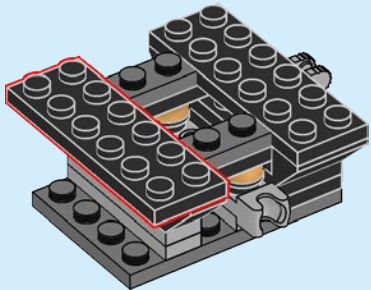

32

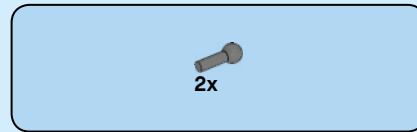
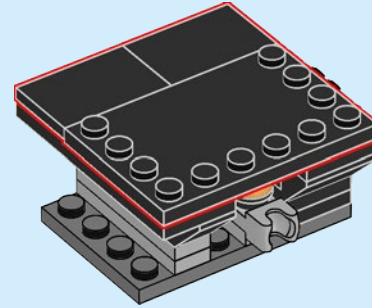

33

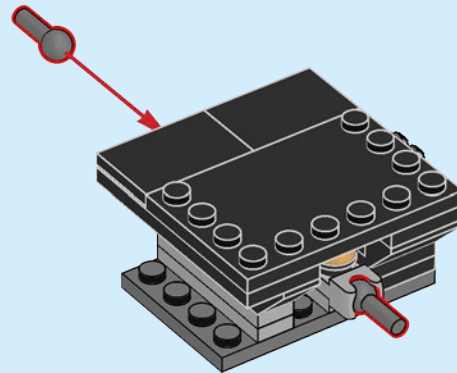

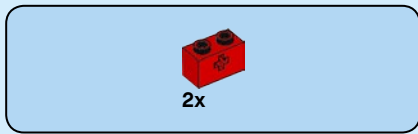

34

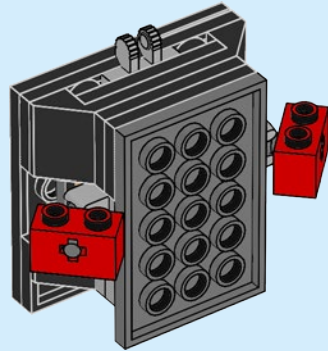

2x

35

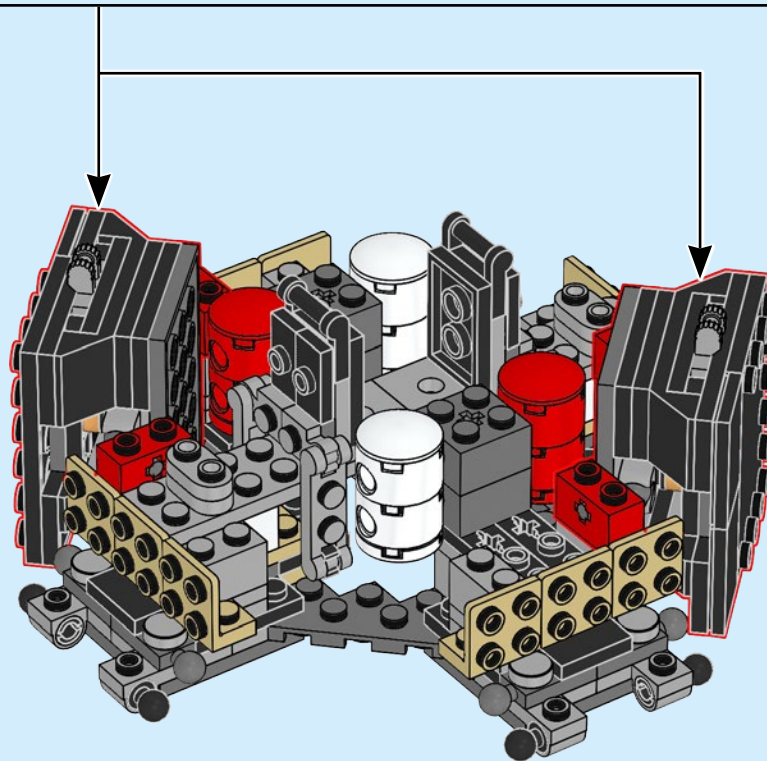

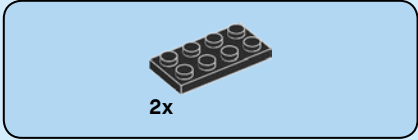
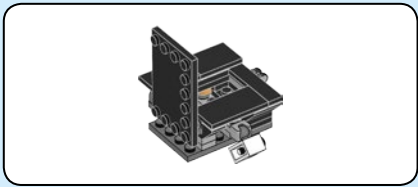

2x

36

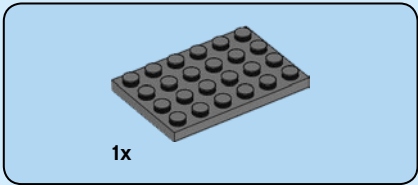
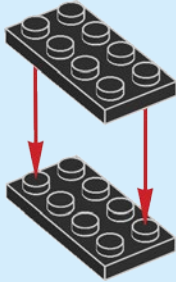

1x

37

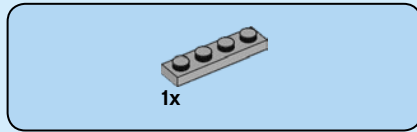
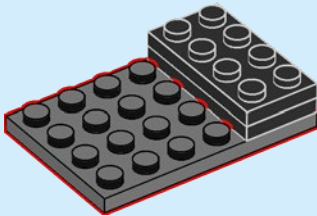

1x

38

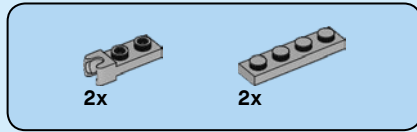
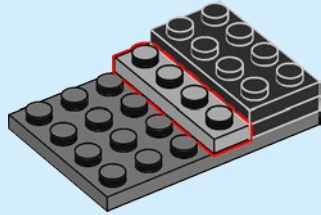

2x

2x

39

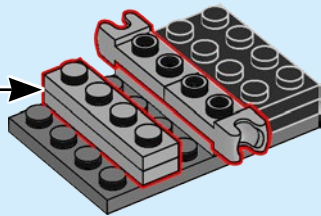
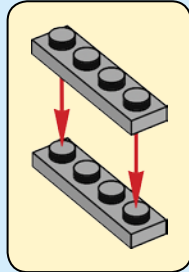



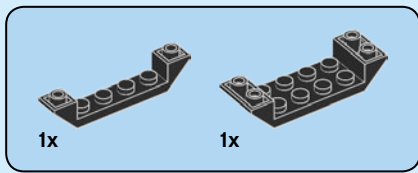

40

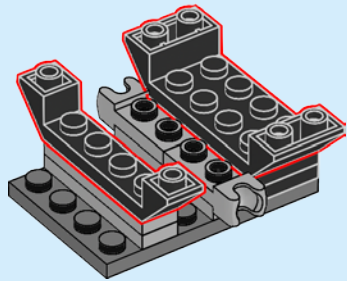

41

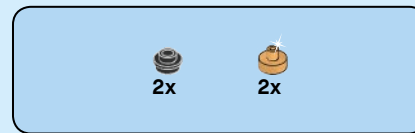
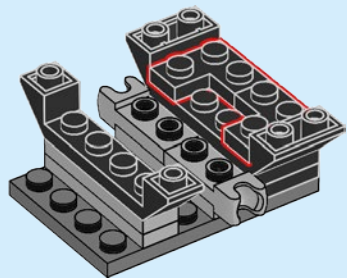

42

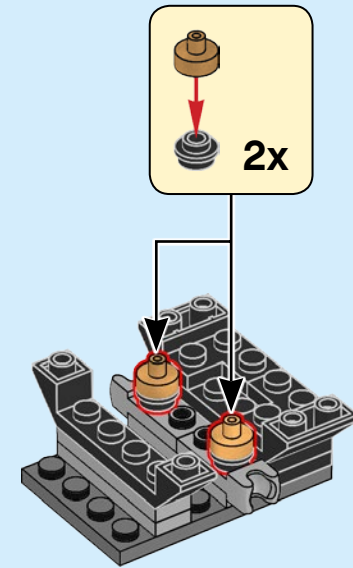

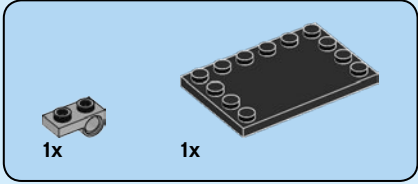
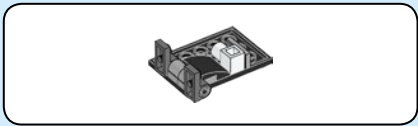

43

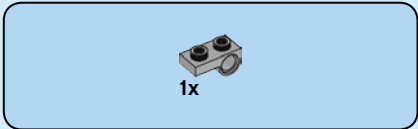
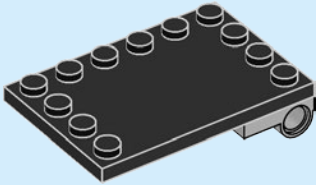

44

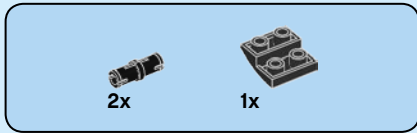
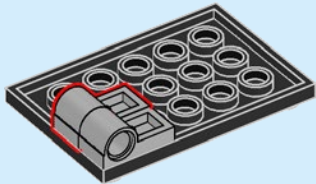

45

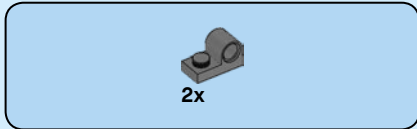
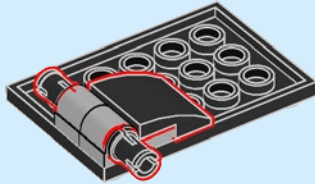

46

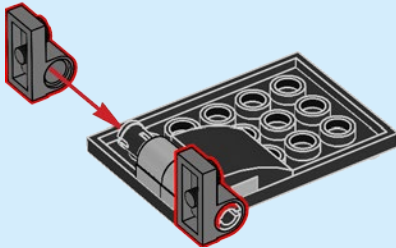



47

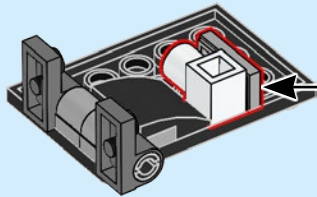
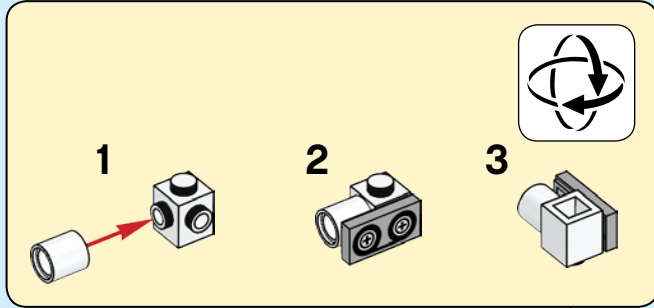

48

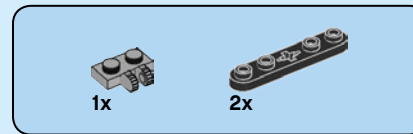
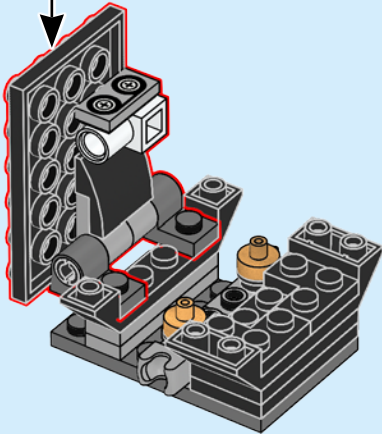

49

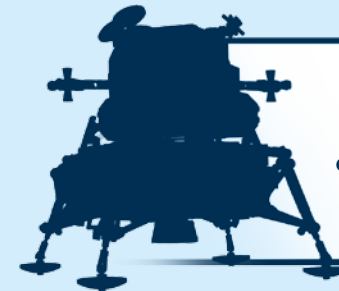
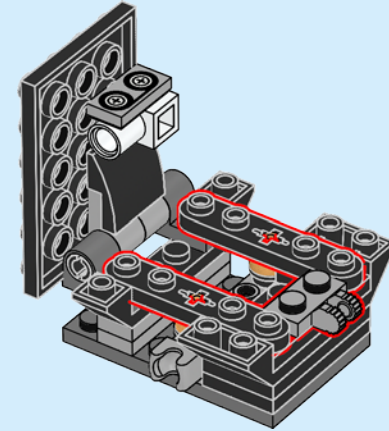

The camera in quadrant 4 filmed Armstrong as he climbed down the ladder and placed his foot on the moon.



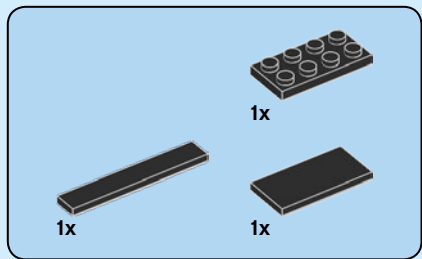

50

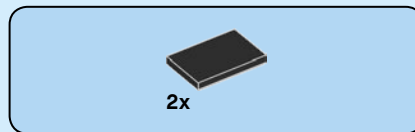
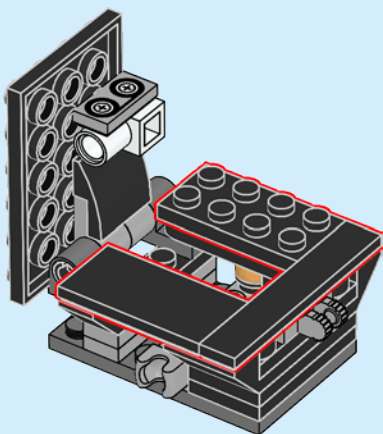

51

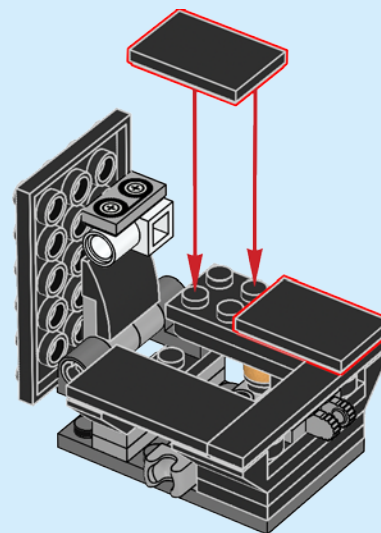

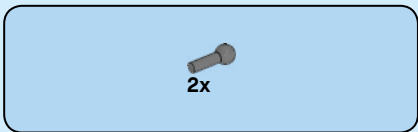

52

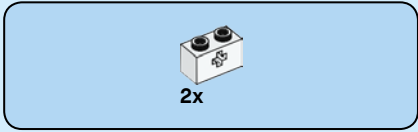
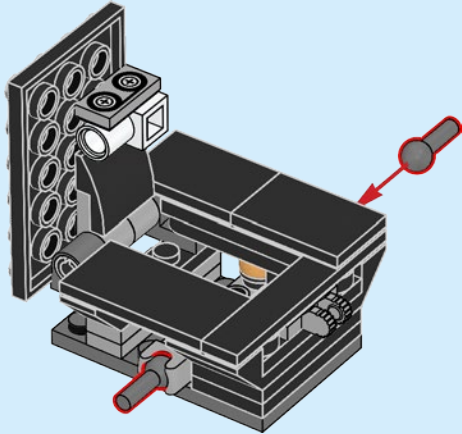

53

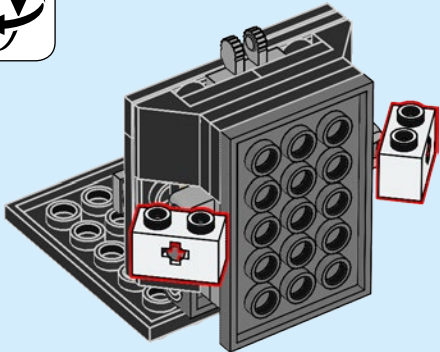

54

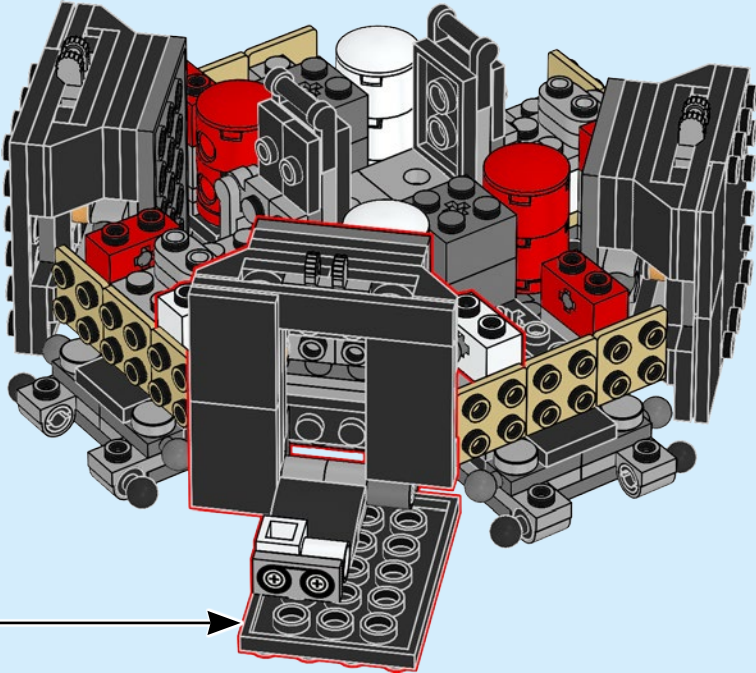

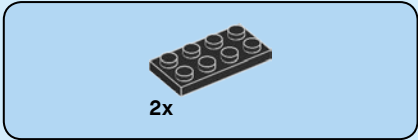

55

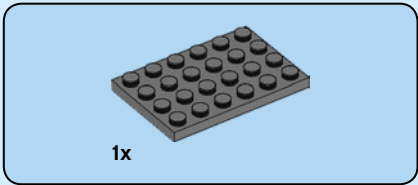
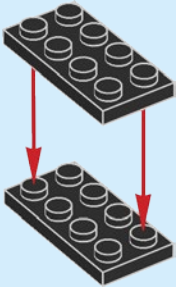

56

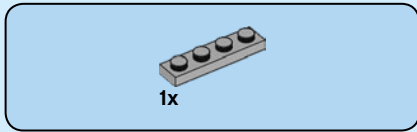
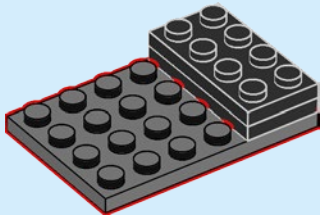

57

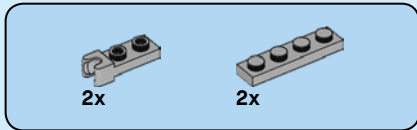
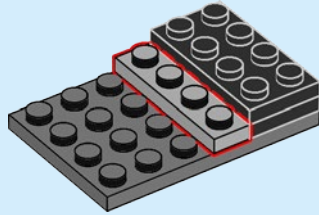

58

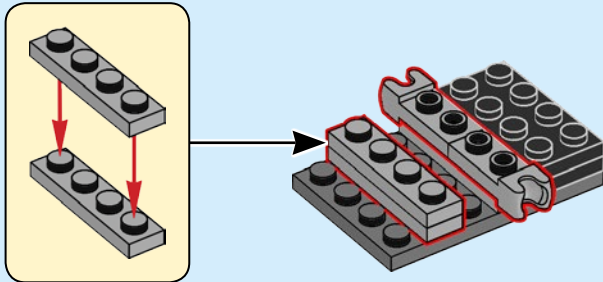



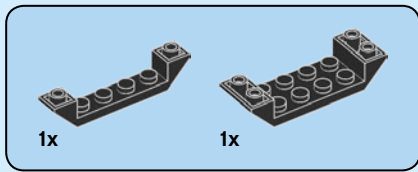

59

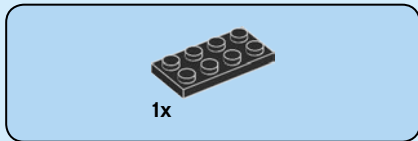
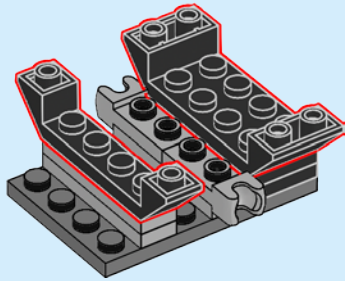

60

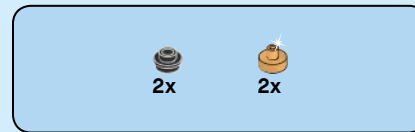
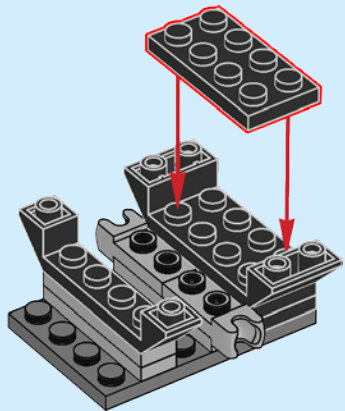

61

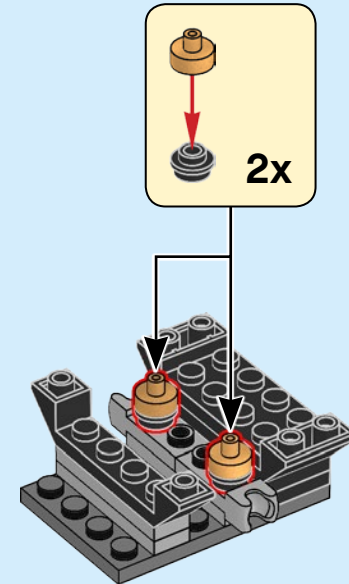

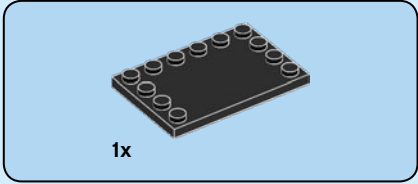
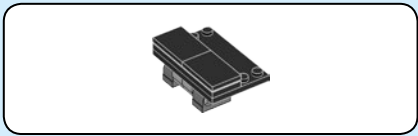

1x

62

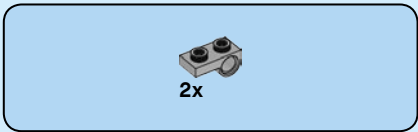
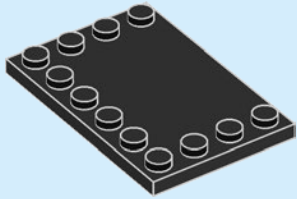

2x

63

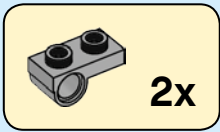

2x

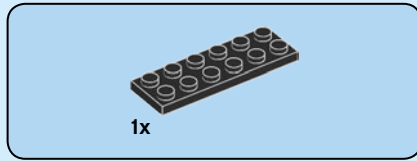
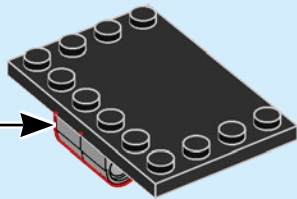

1x

64

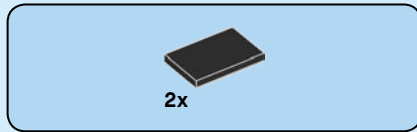
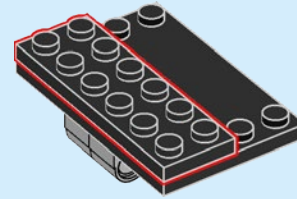

2x

65

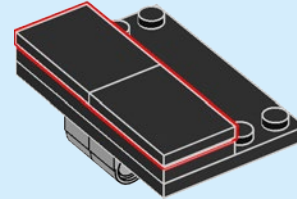

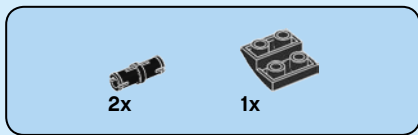

66

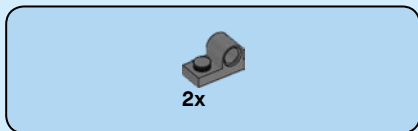
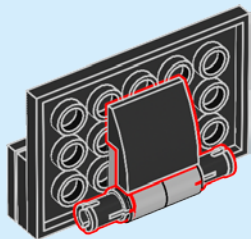

67

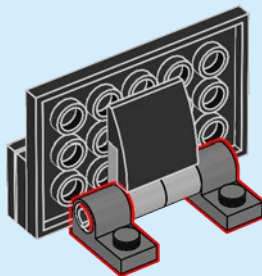

68

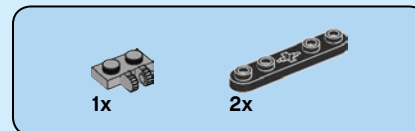
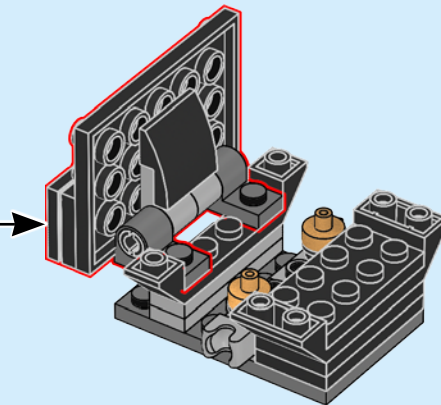

69

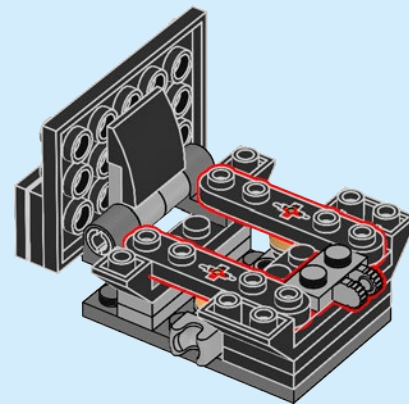



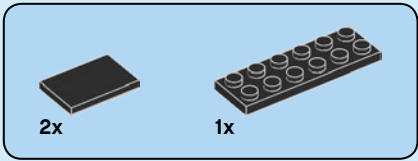

70

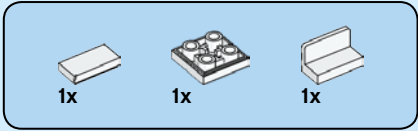
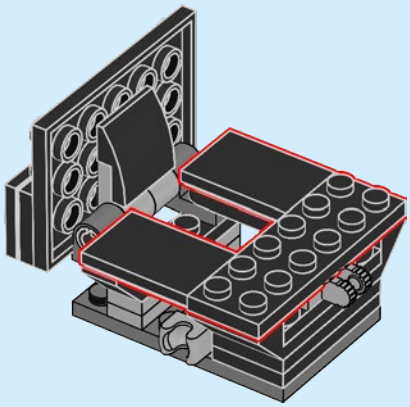

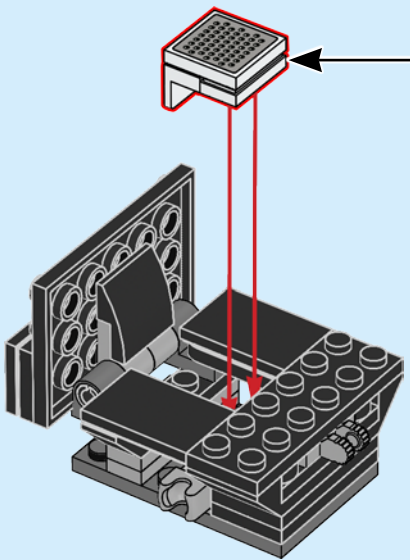

71

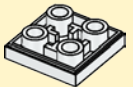

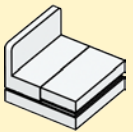
1 

2 

3 

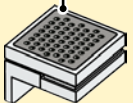

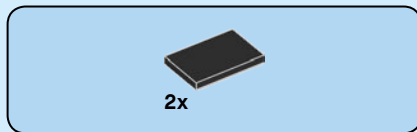
72

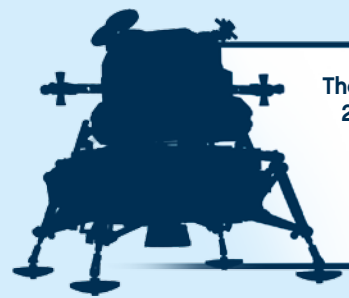
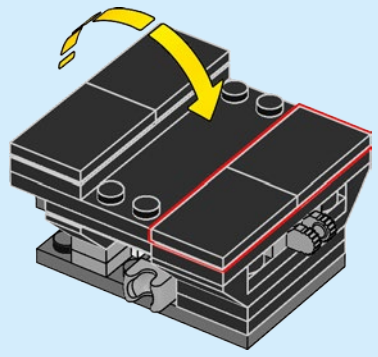

The laser reflector in quadrant 2 was placed on the surface of the moon. When a laser light was pointed at it from Earth, the distance to the moon could be measured.

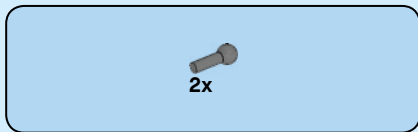

73

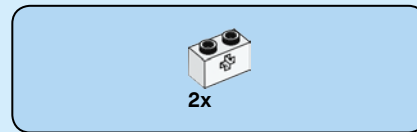
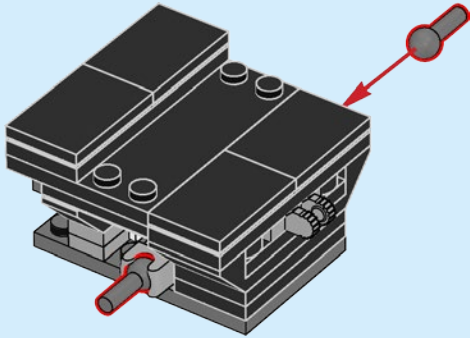

74

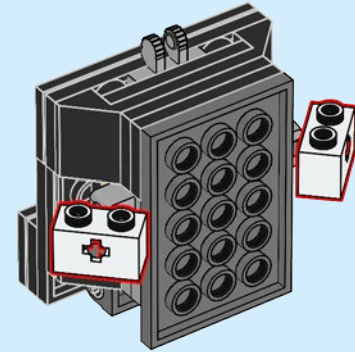

75

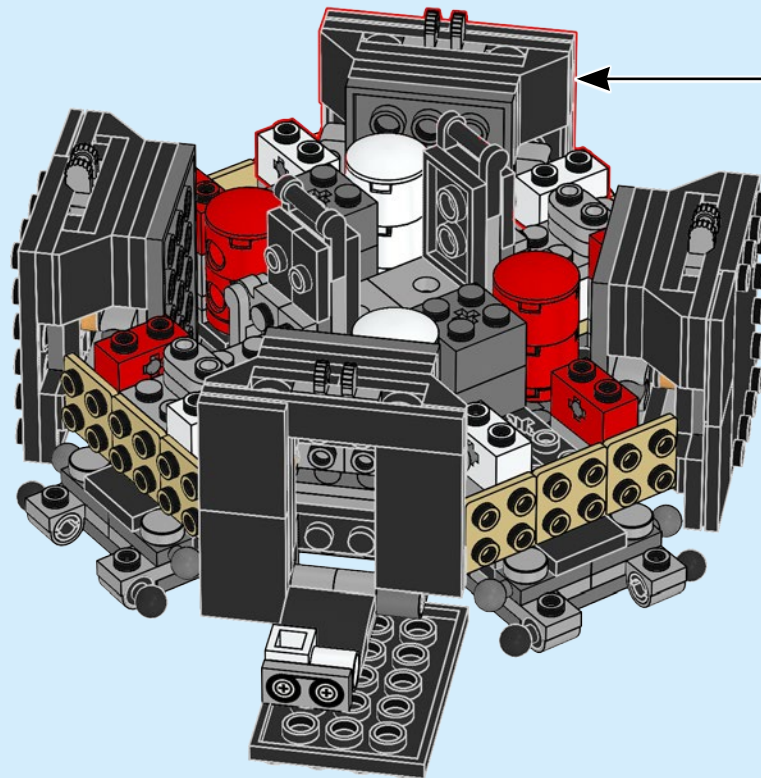

76

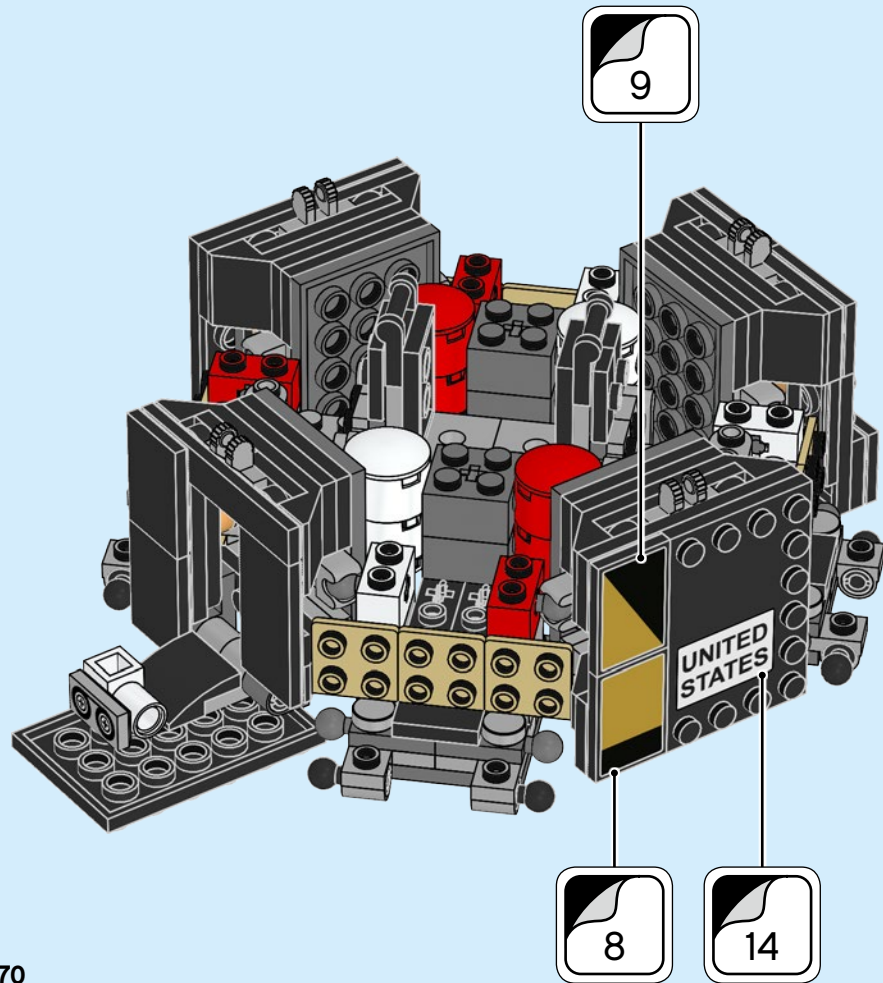

77

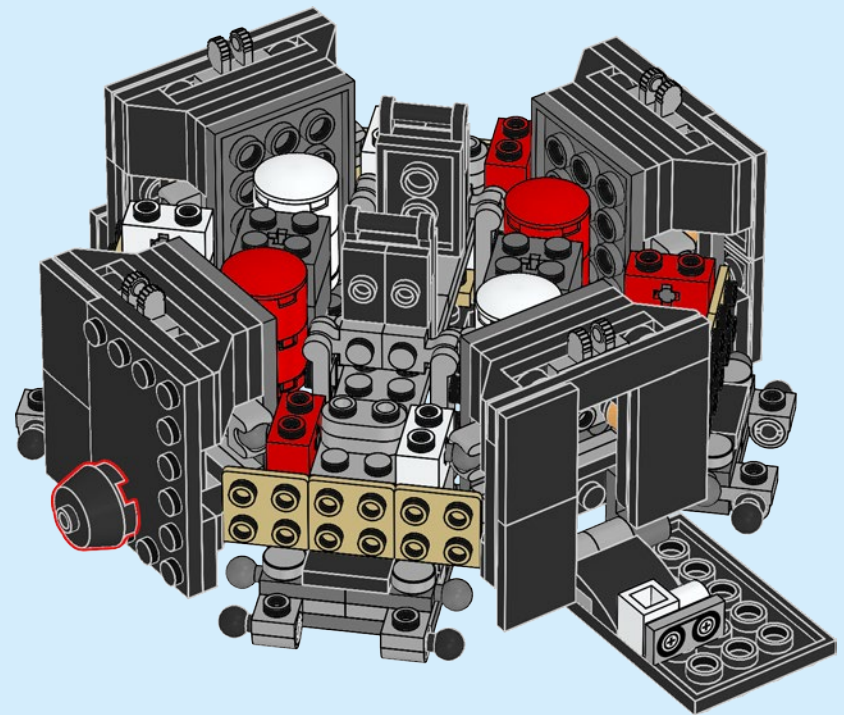
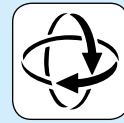



78

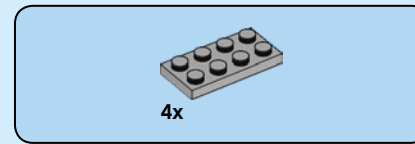
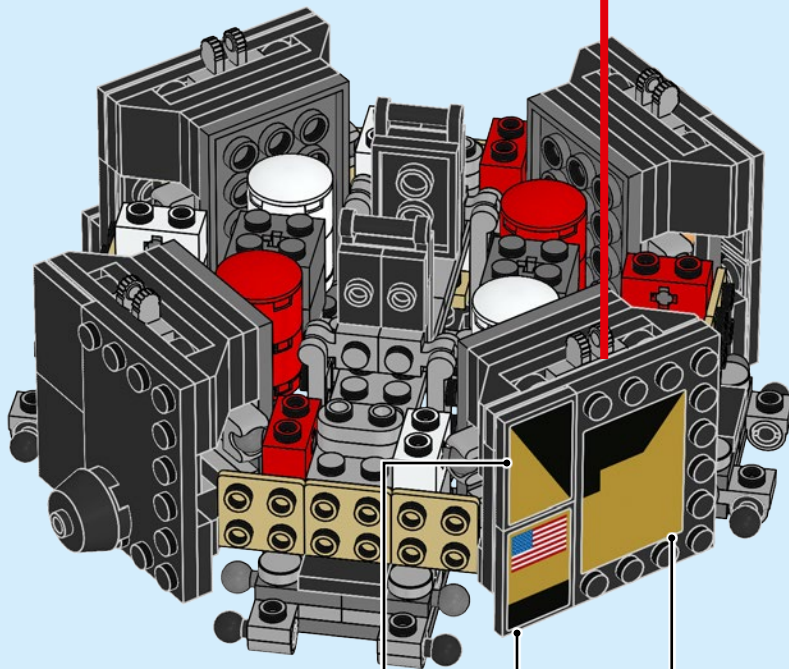
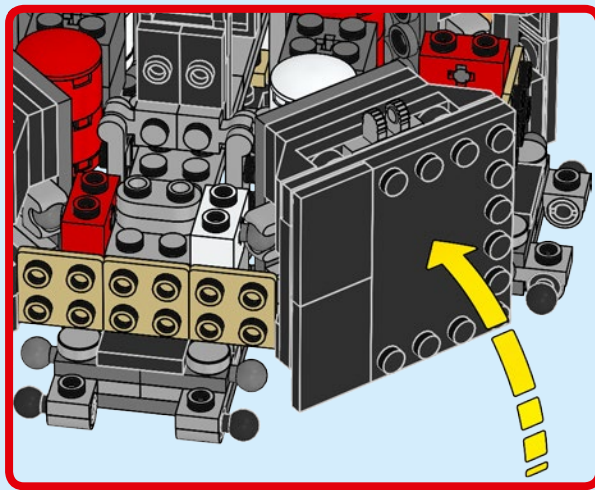

79

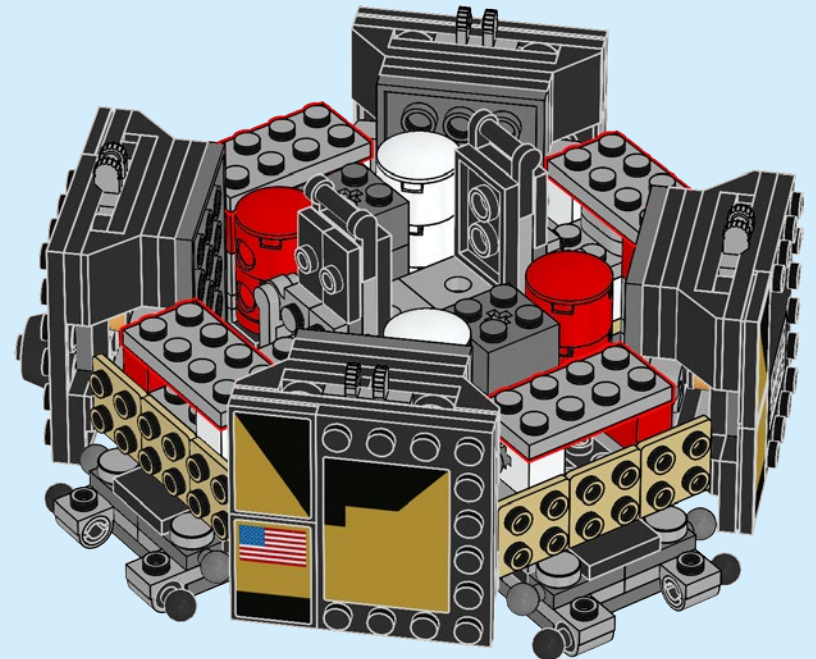

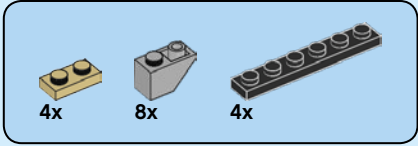
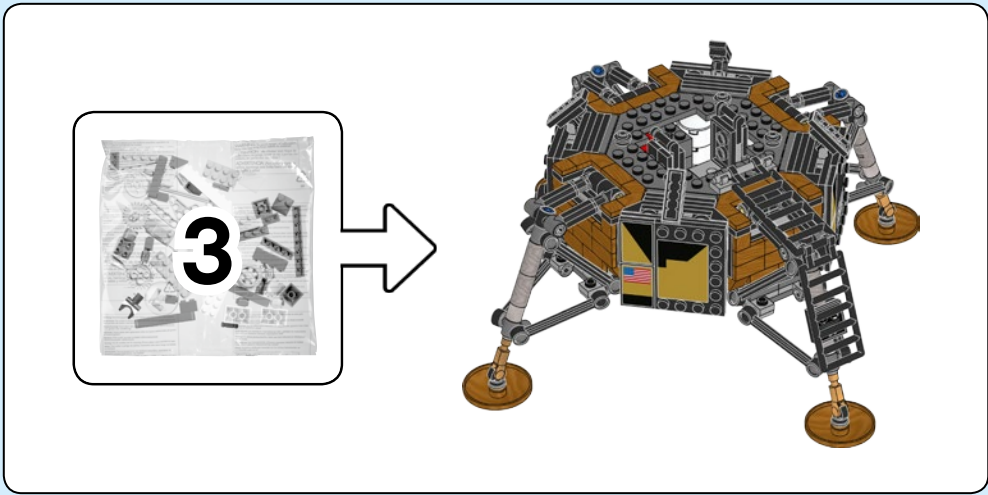

80

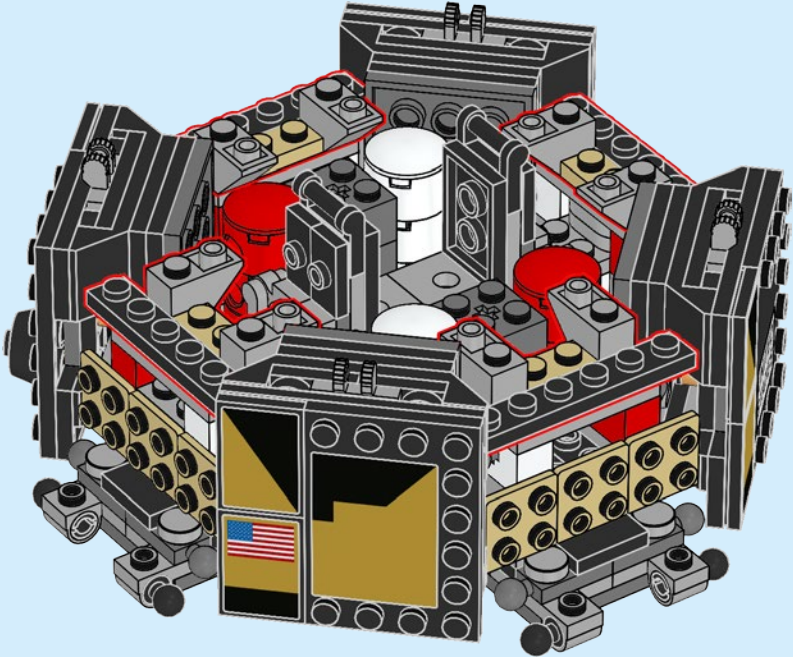

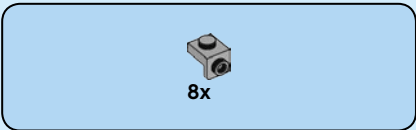

81

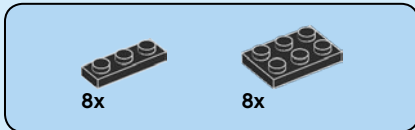
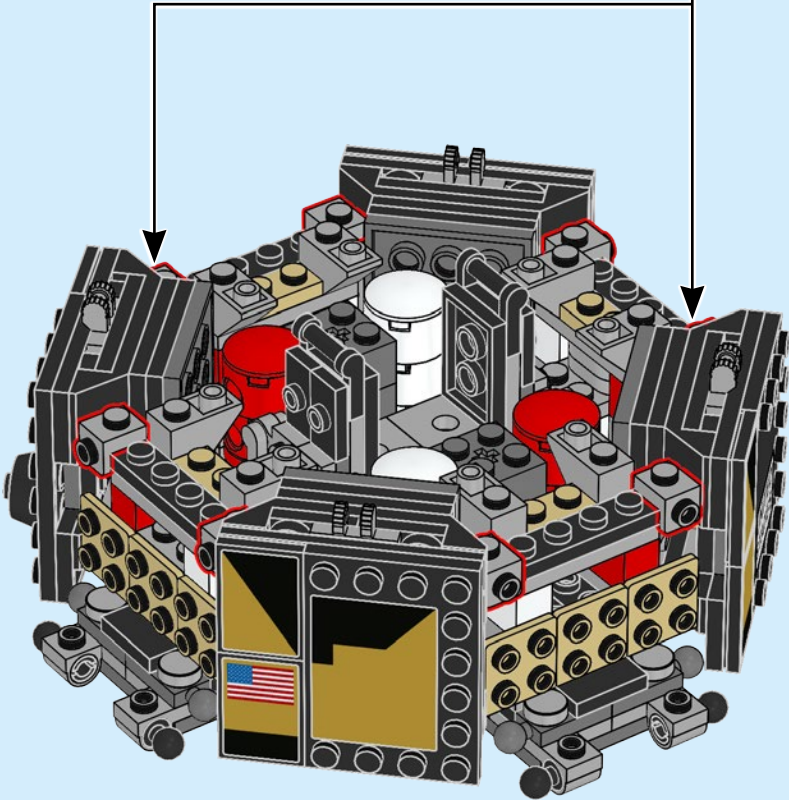
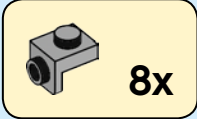

82

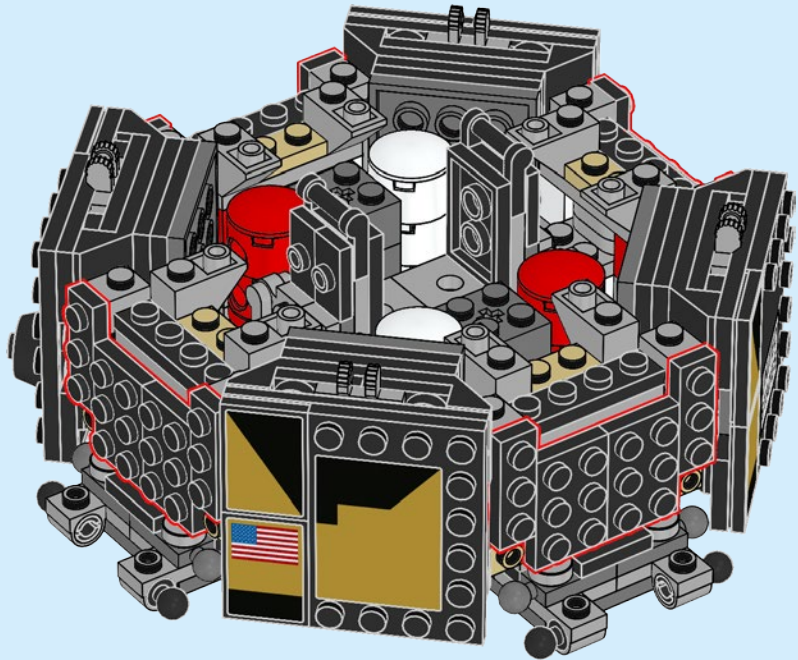





8x



8x



32x

83

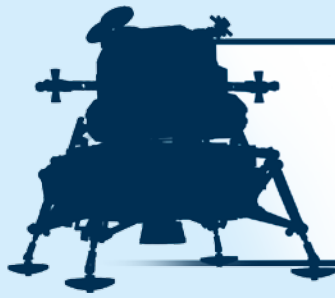

The foil on the Lunar Lander was used for thermal and micrometeoroid protection.

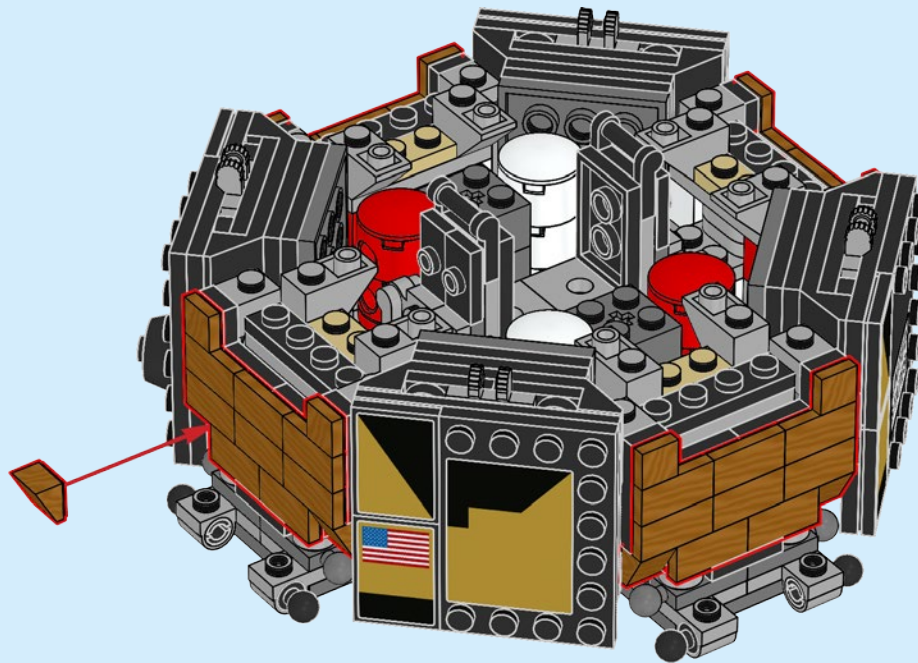

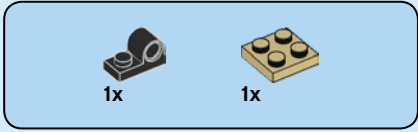

84

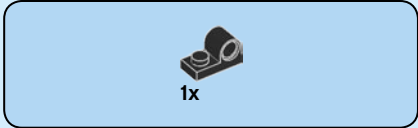
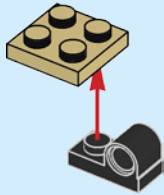

85

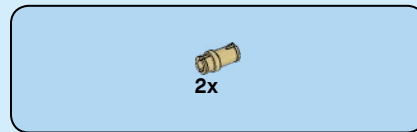
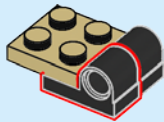

86

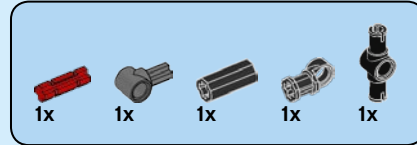
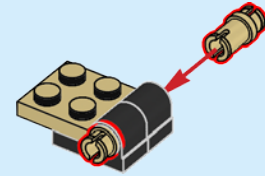

87

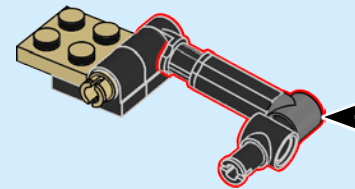
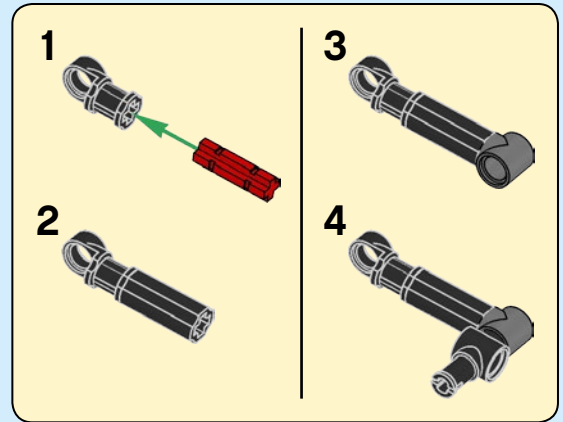

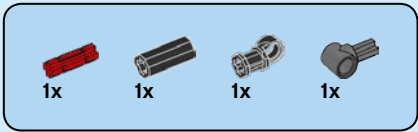

88

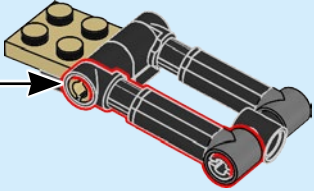
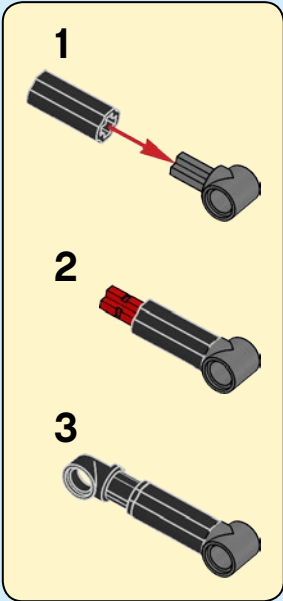

4x

89

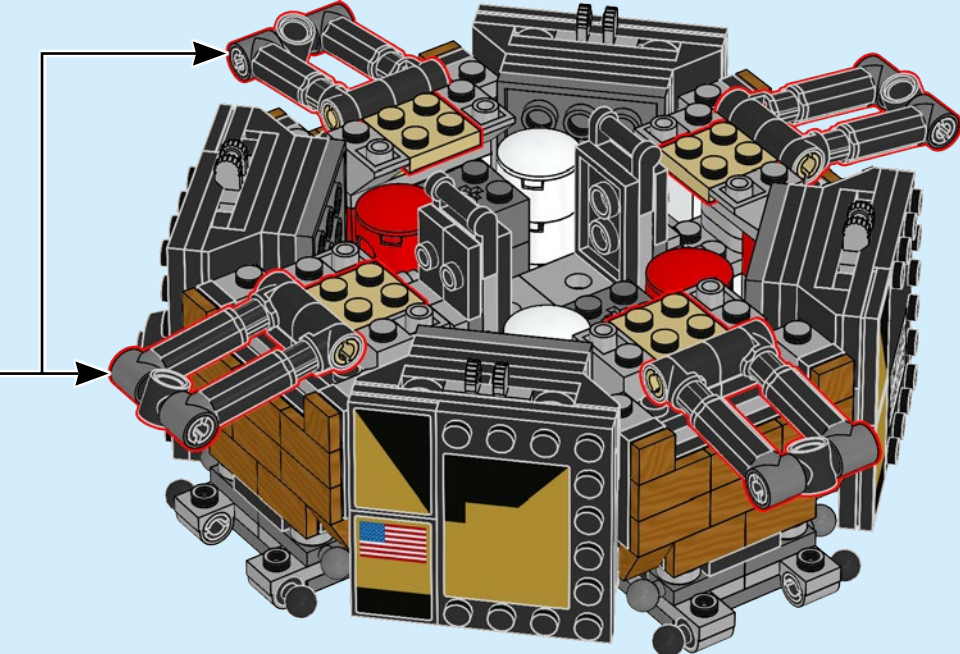



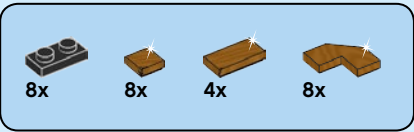

90

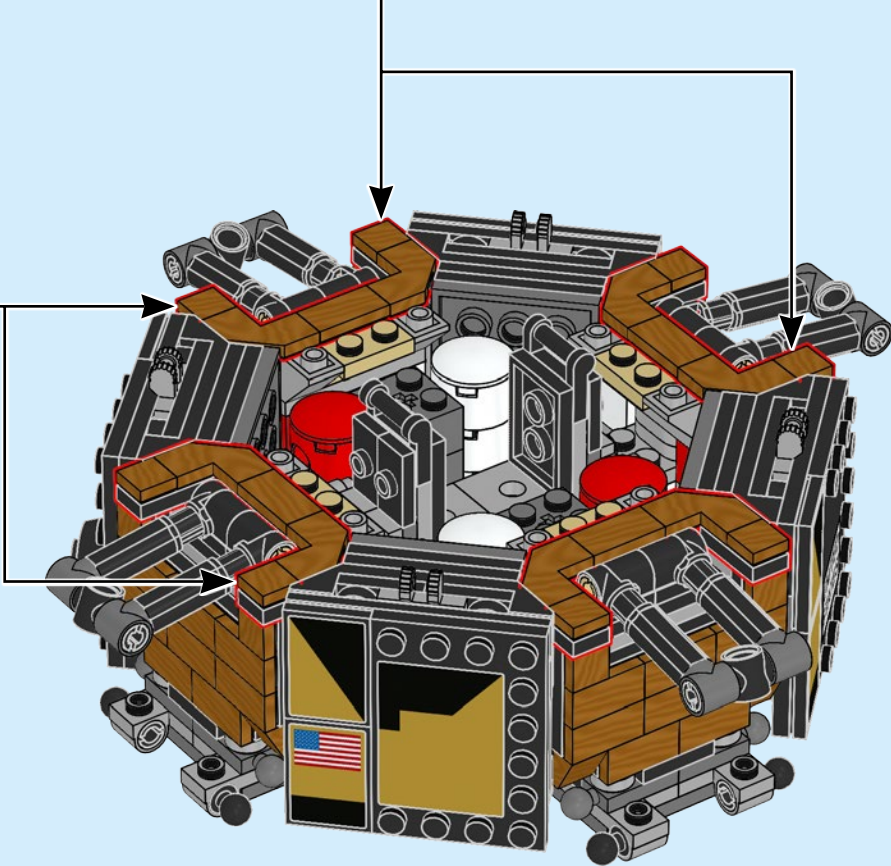
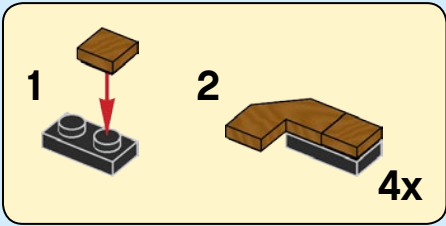
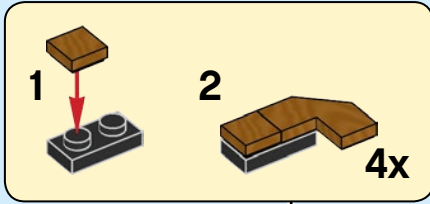

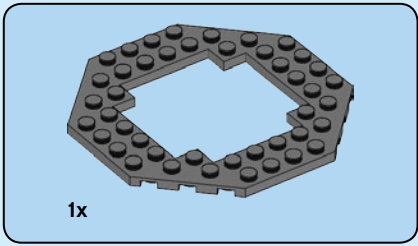

91

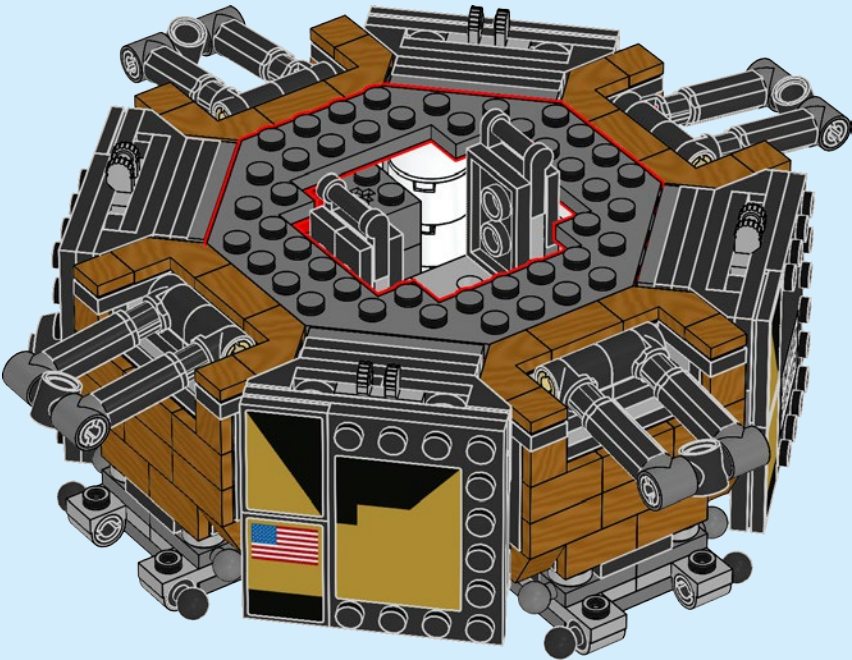

92

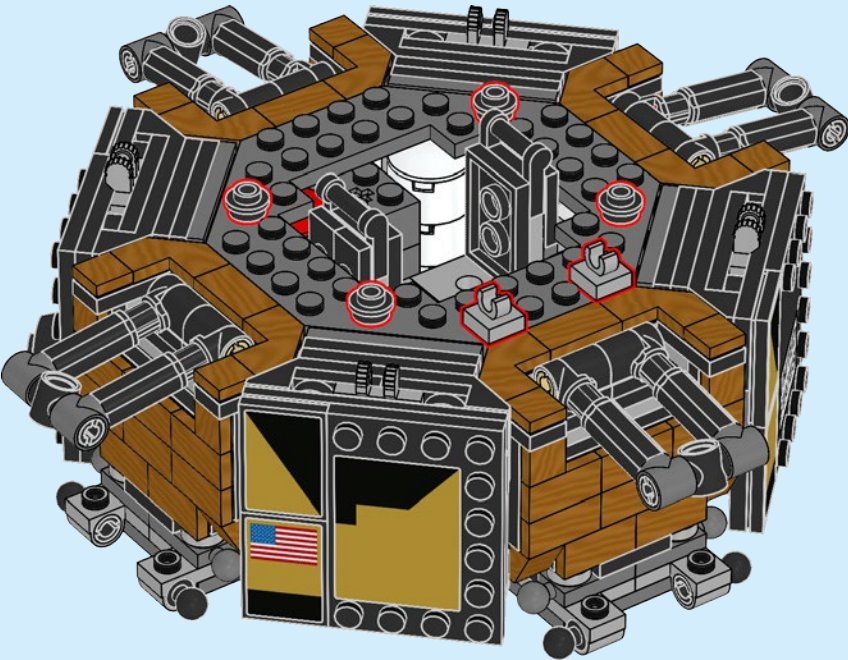

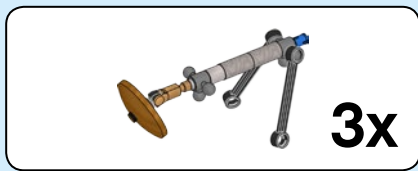

93

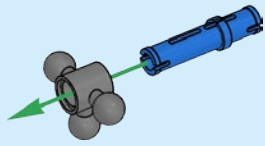

94

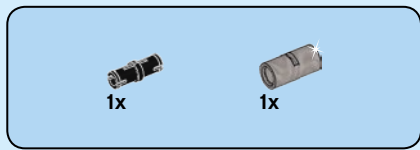
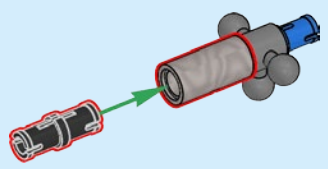

95

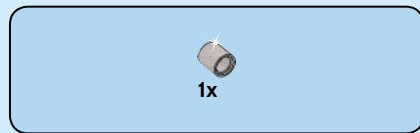
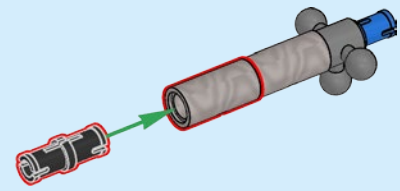

96

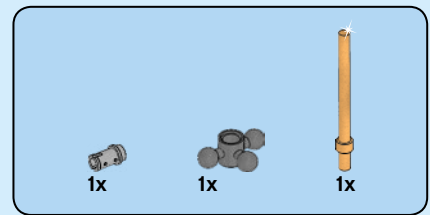
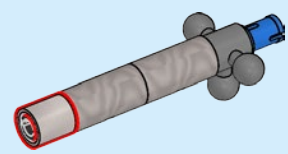

97

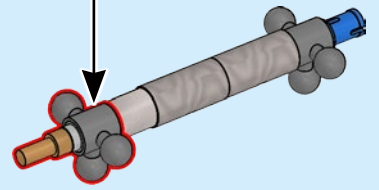
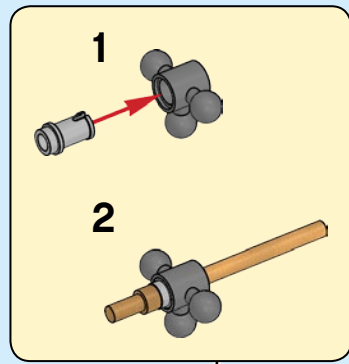





1x

98

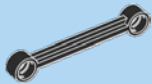
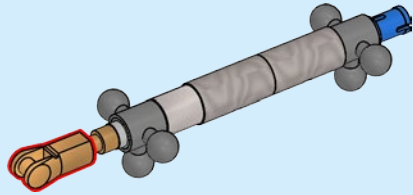

2x

99

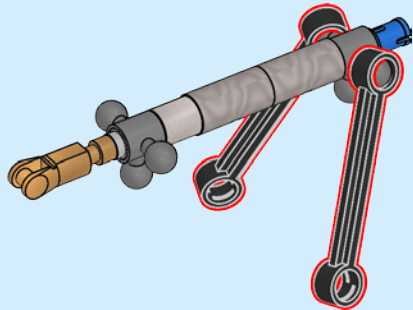

1x

1x

1x

100

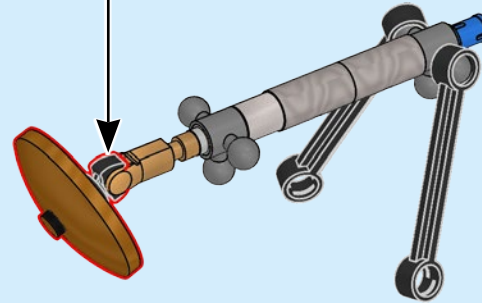
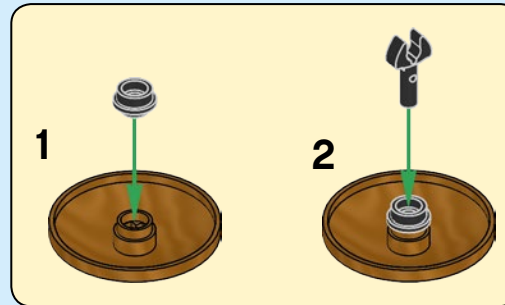

3x

101

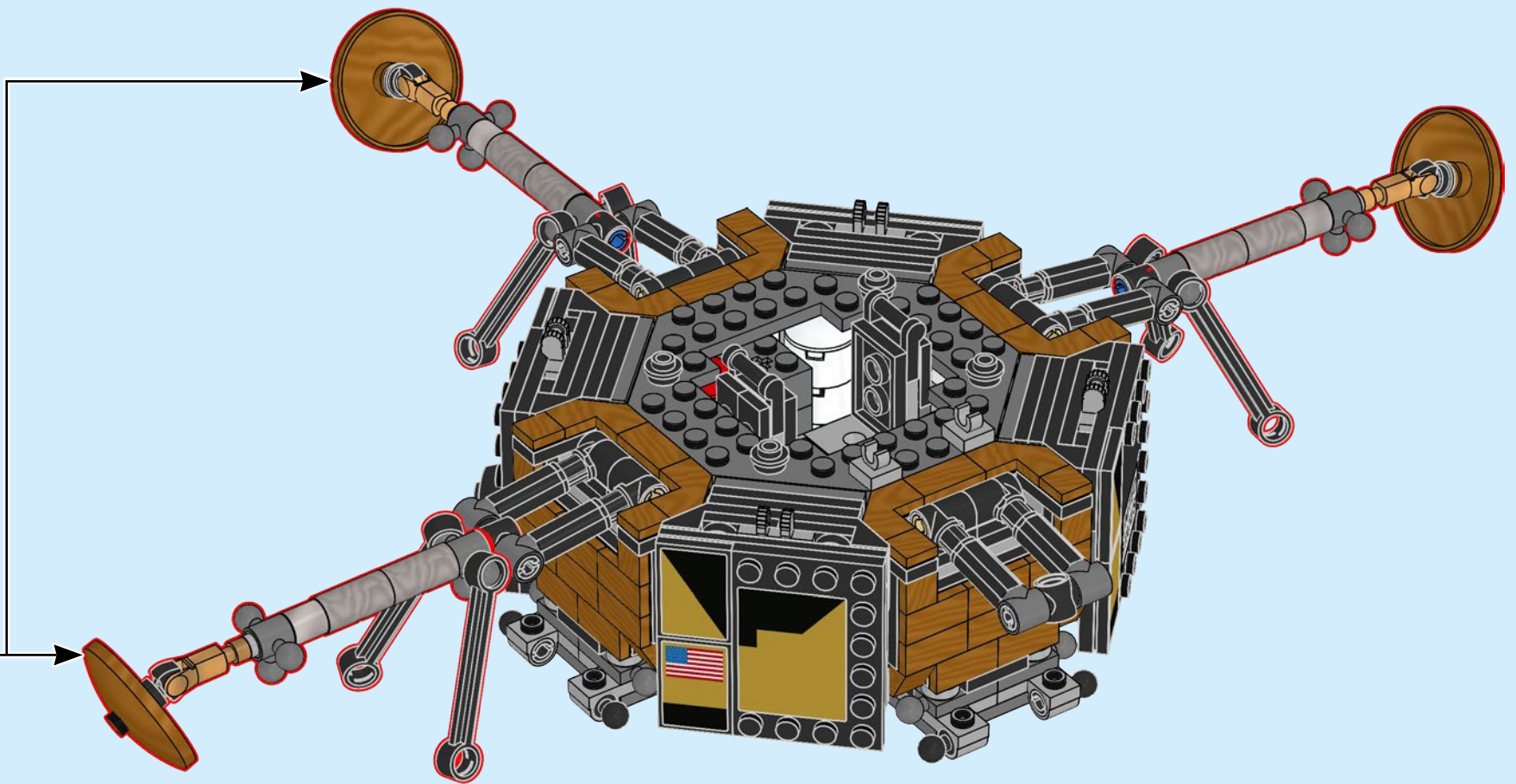

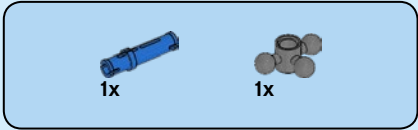
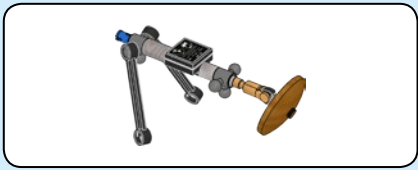

102

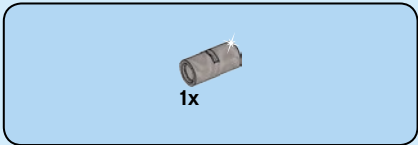
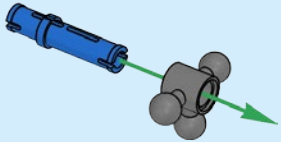

103

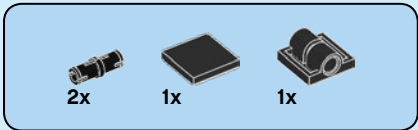
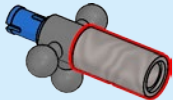

104

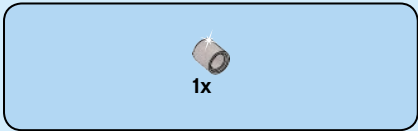
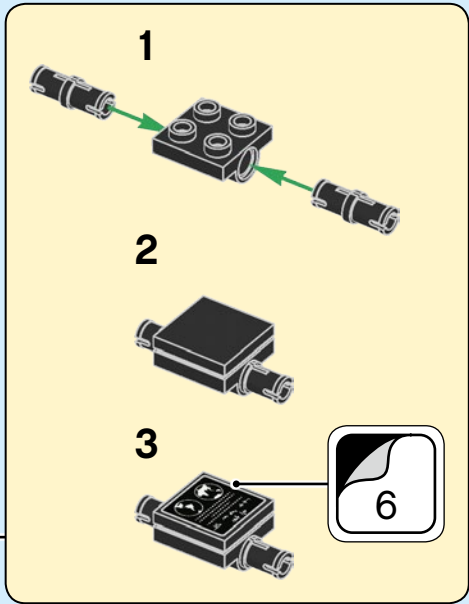
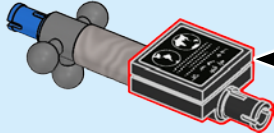

105

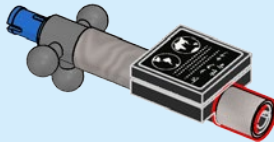



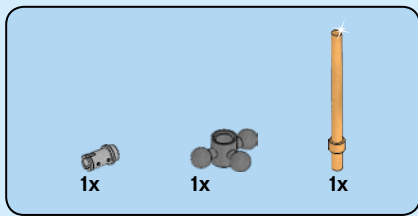

106

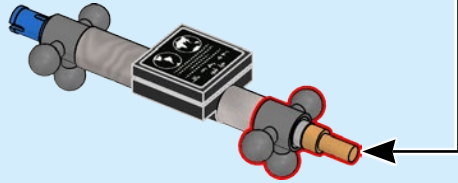
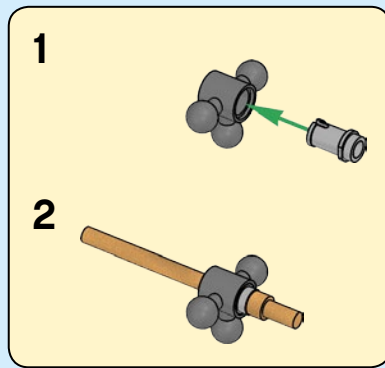

107

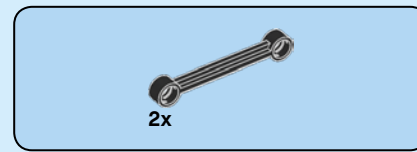
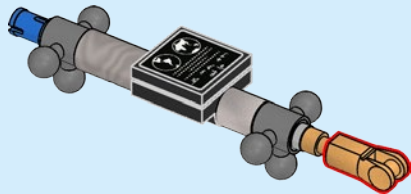

108

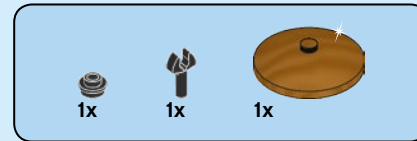
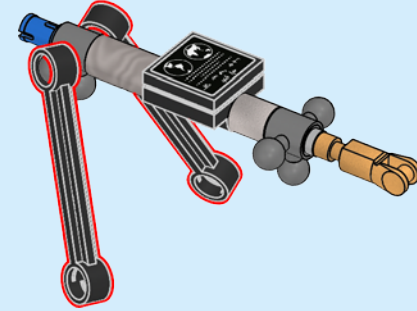

109

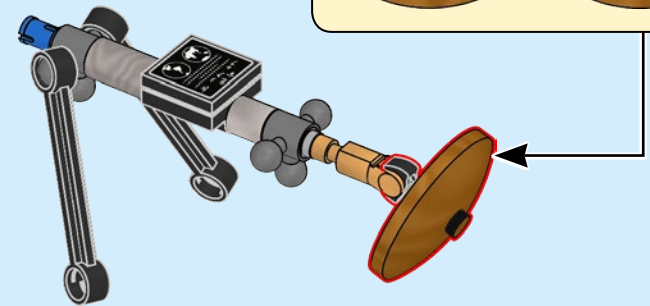
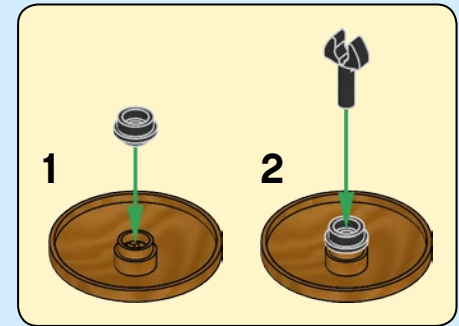

110

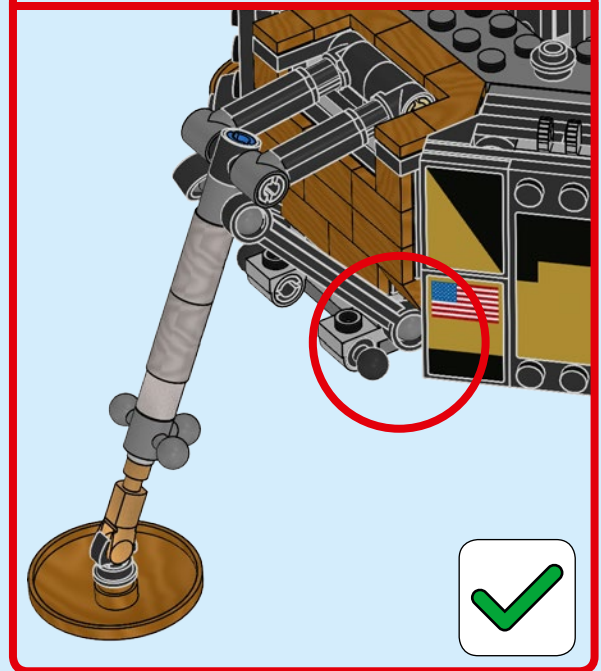
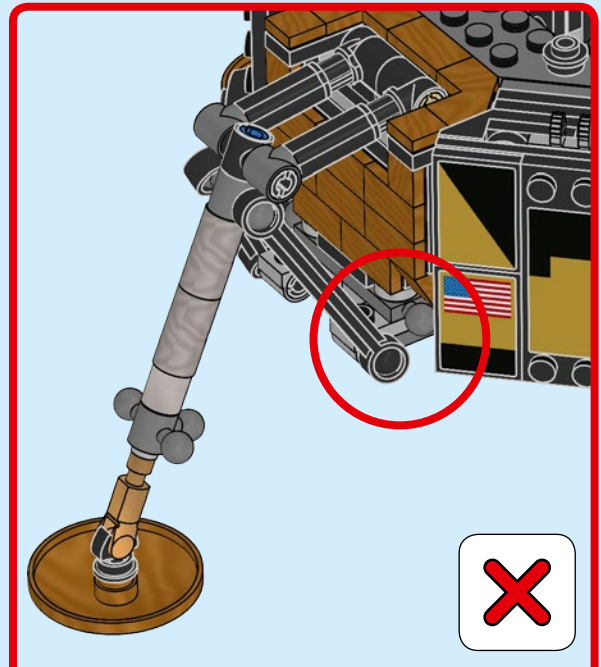
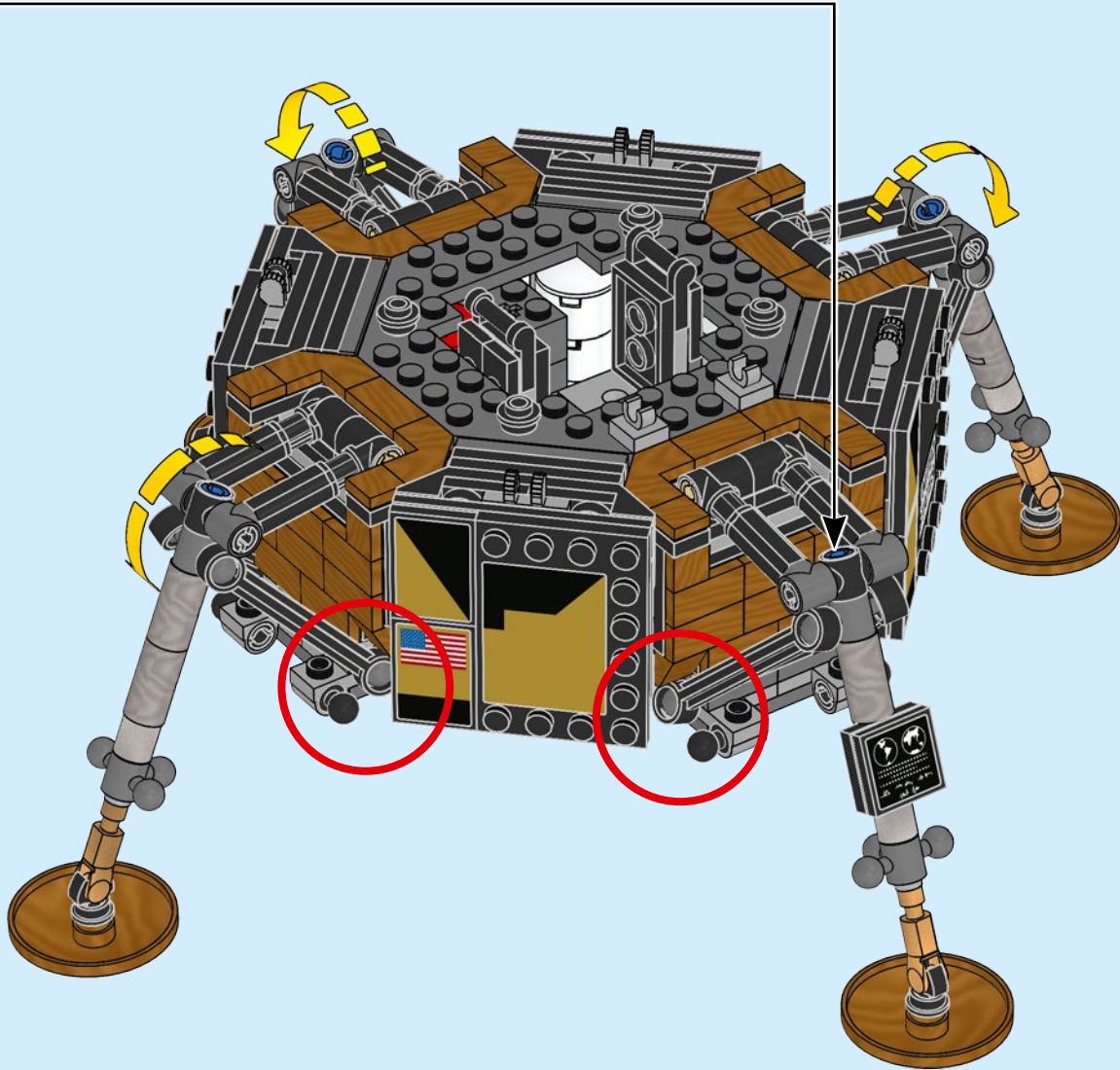

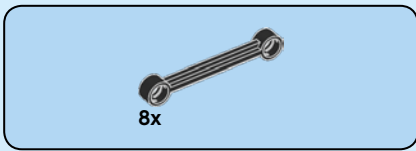

111

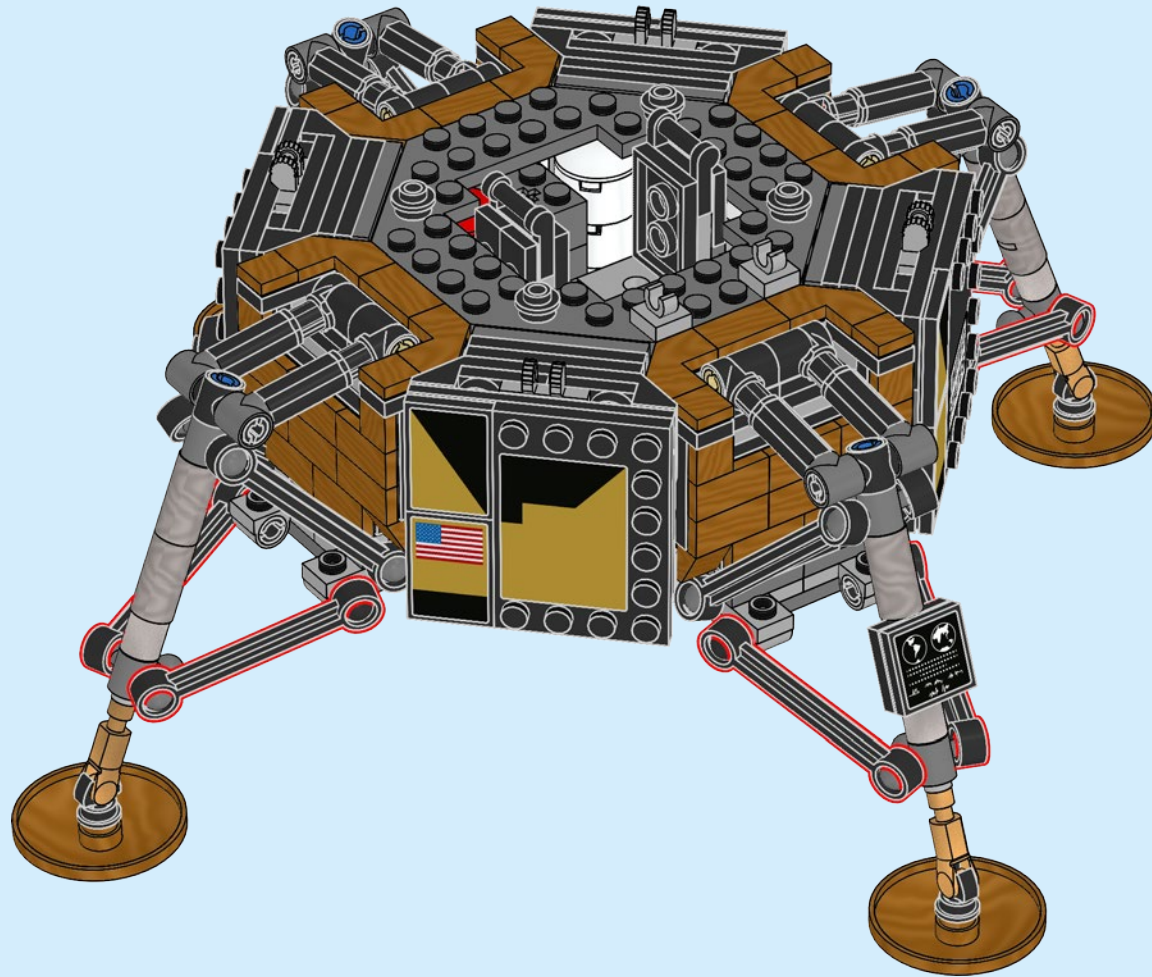



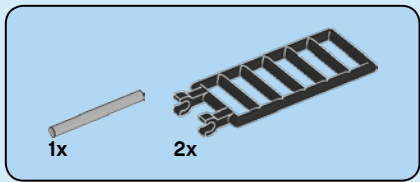

112

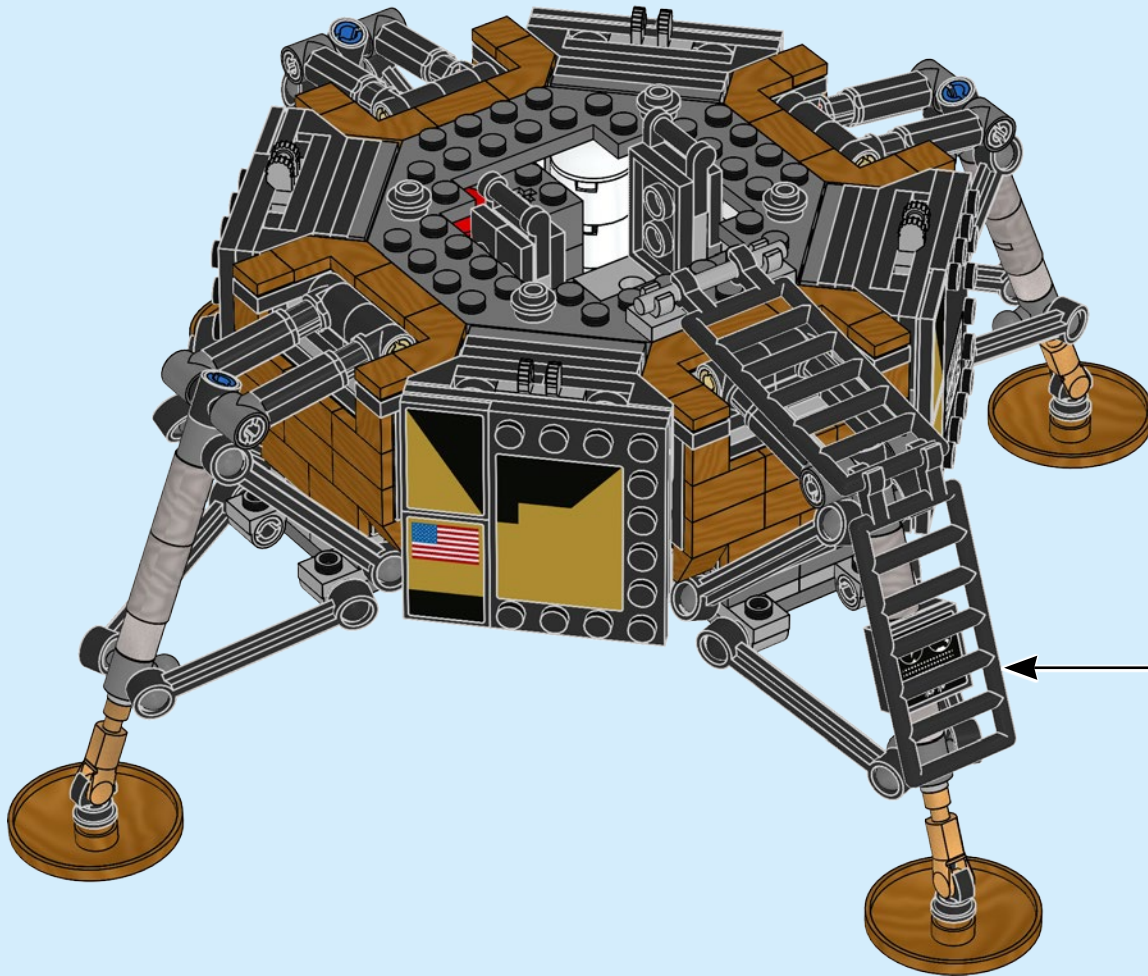
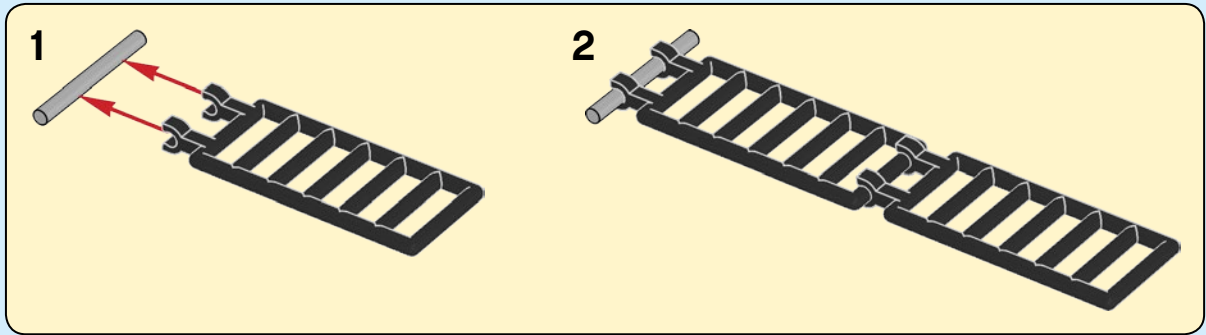



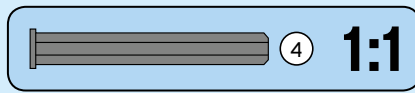
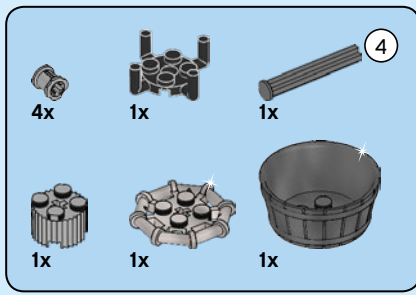

# 113

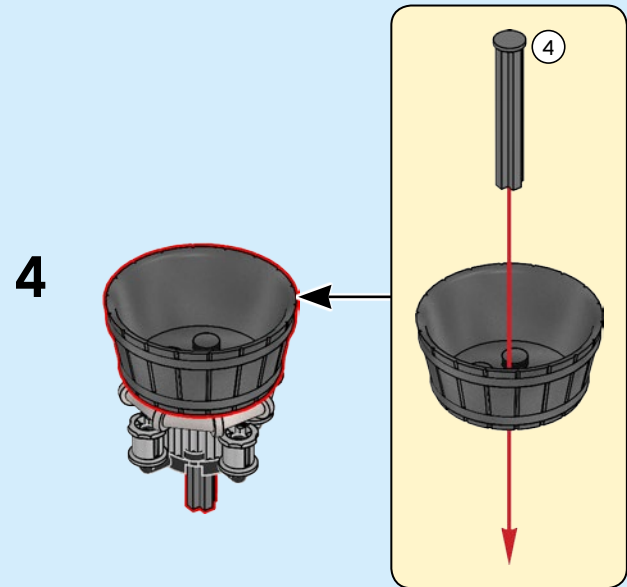
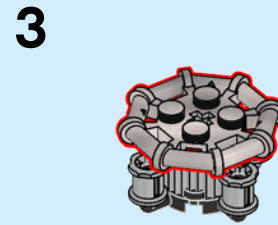
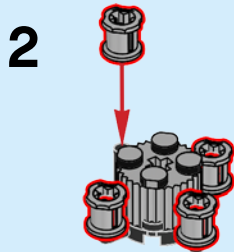
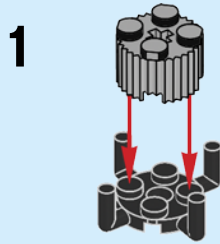

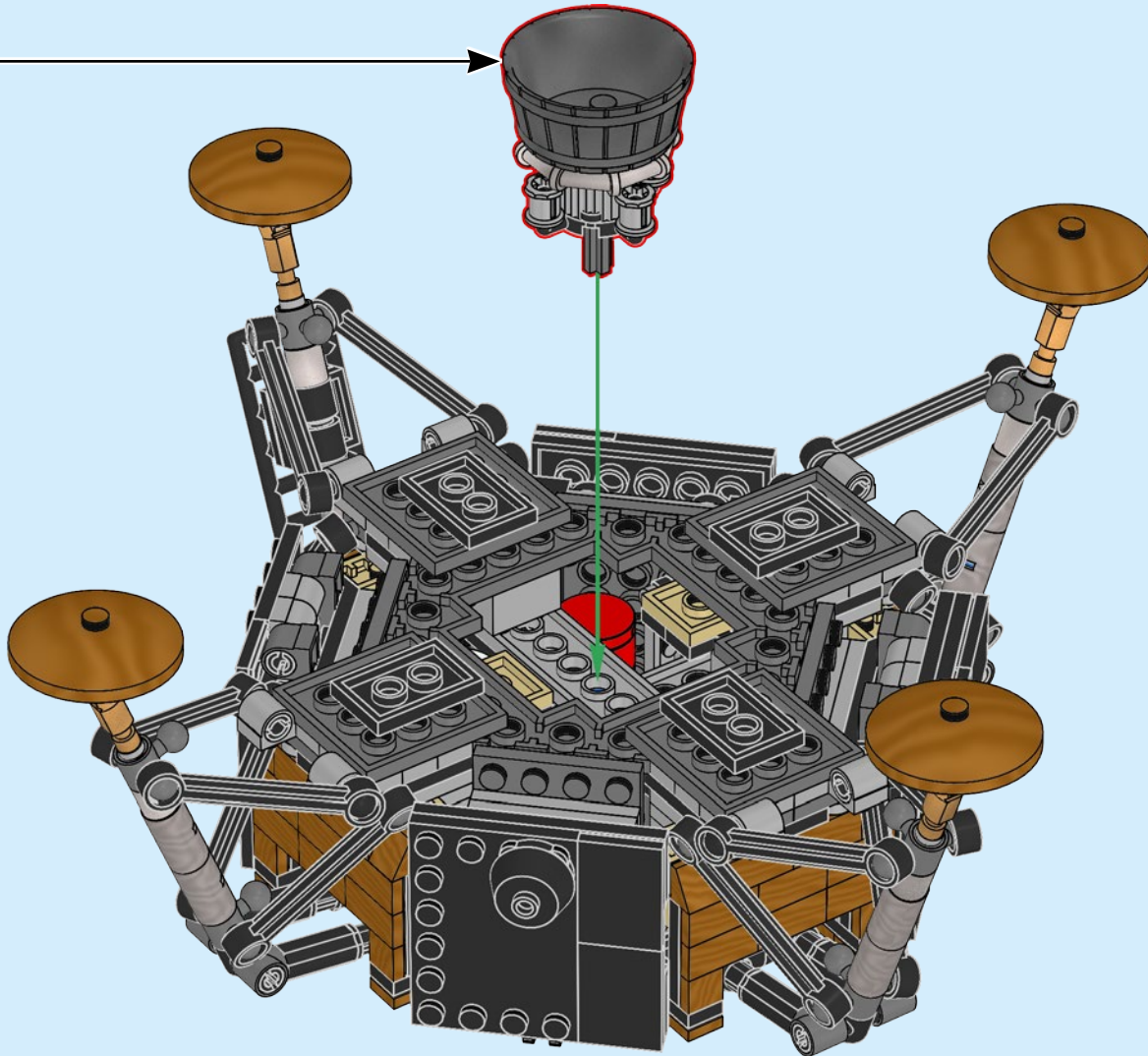

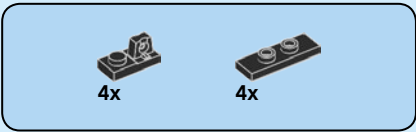

114

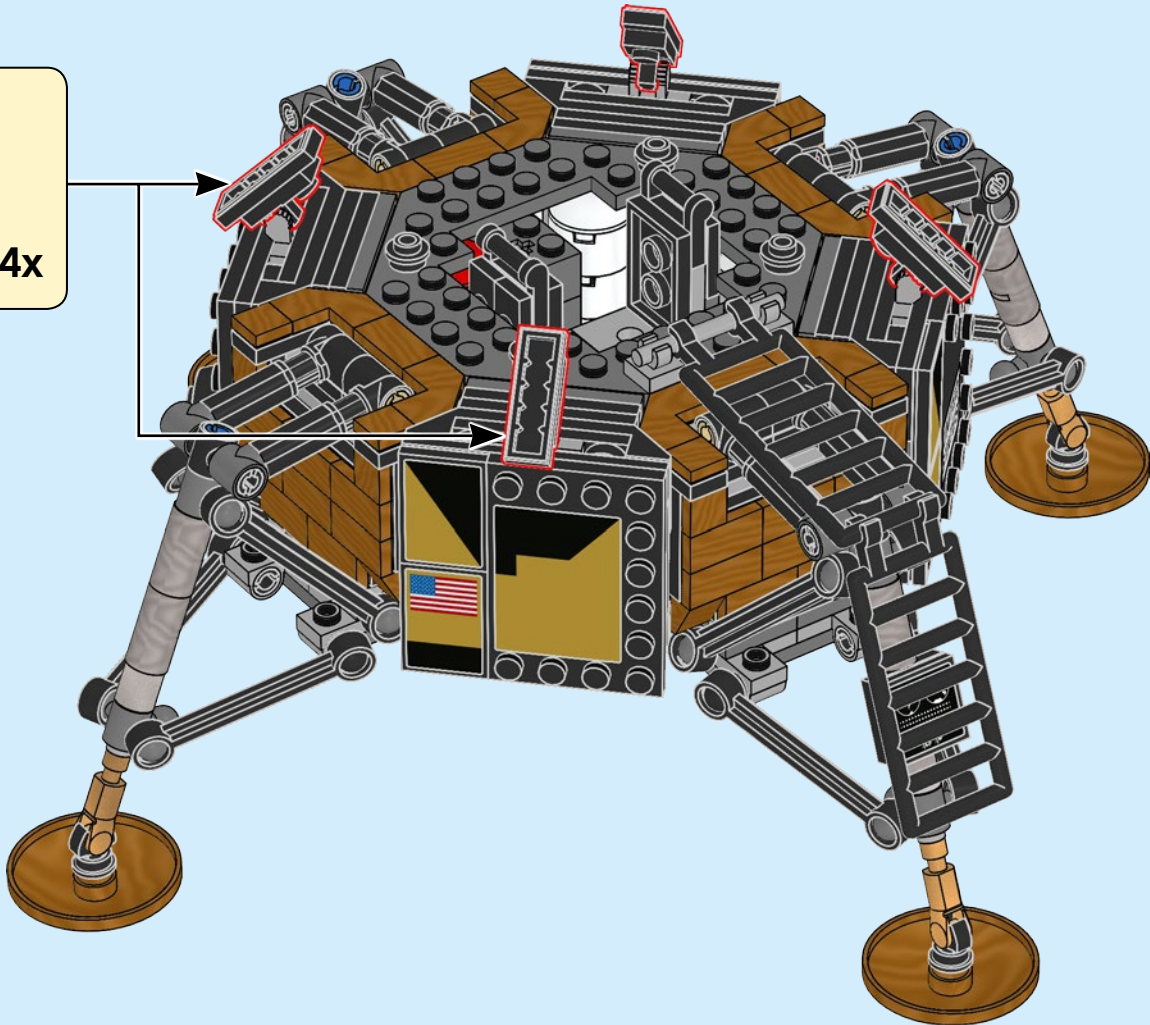
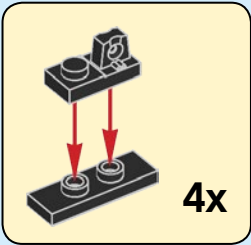



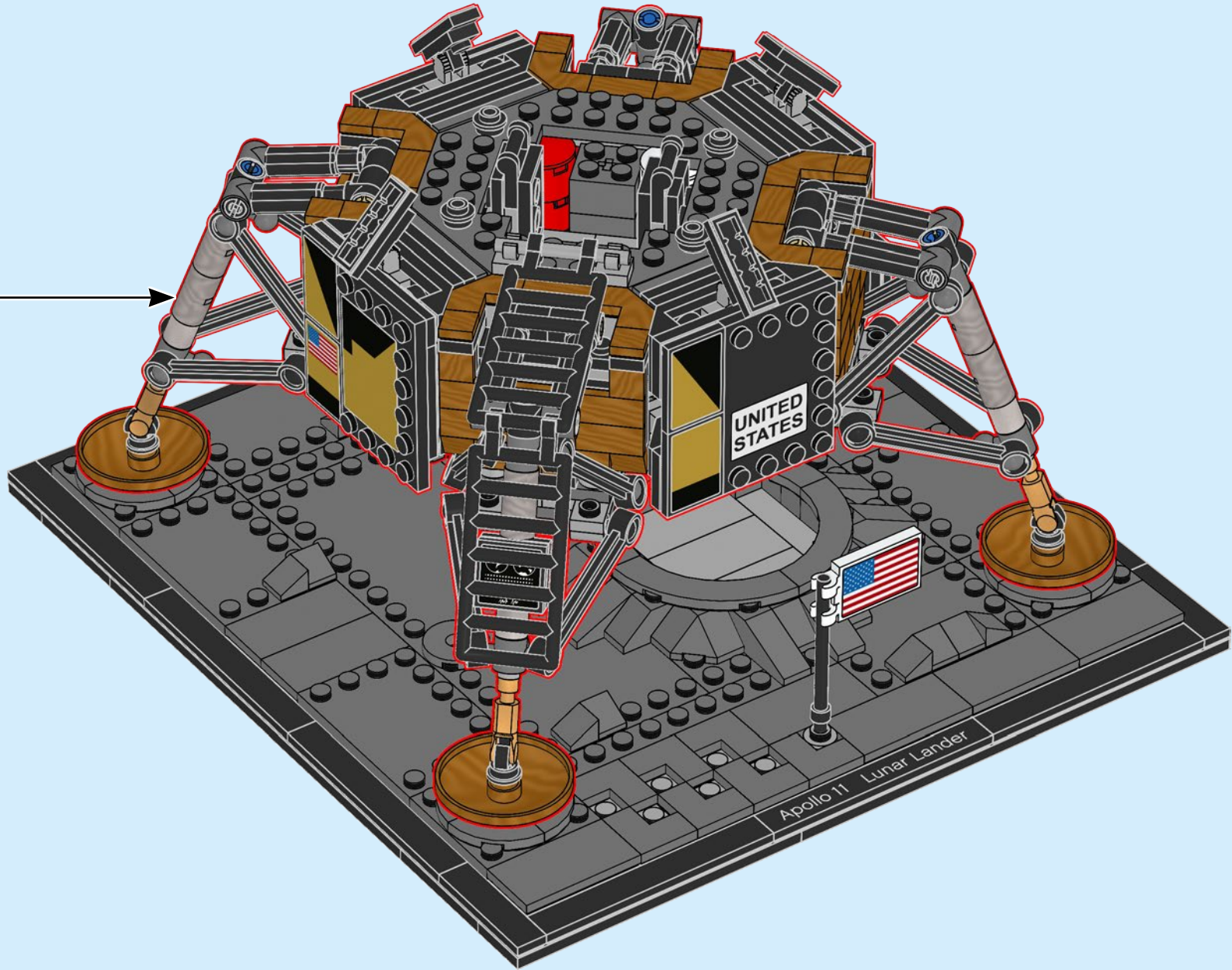



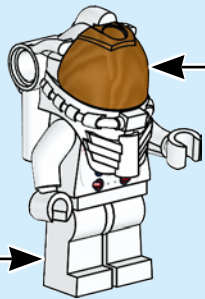
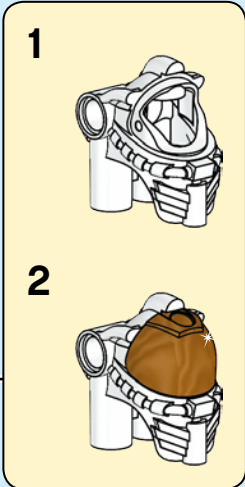
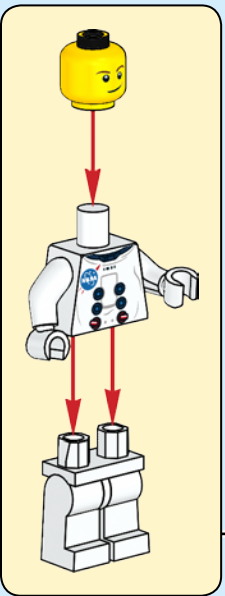
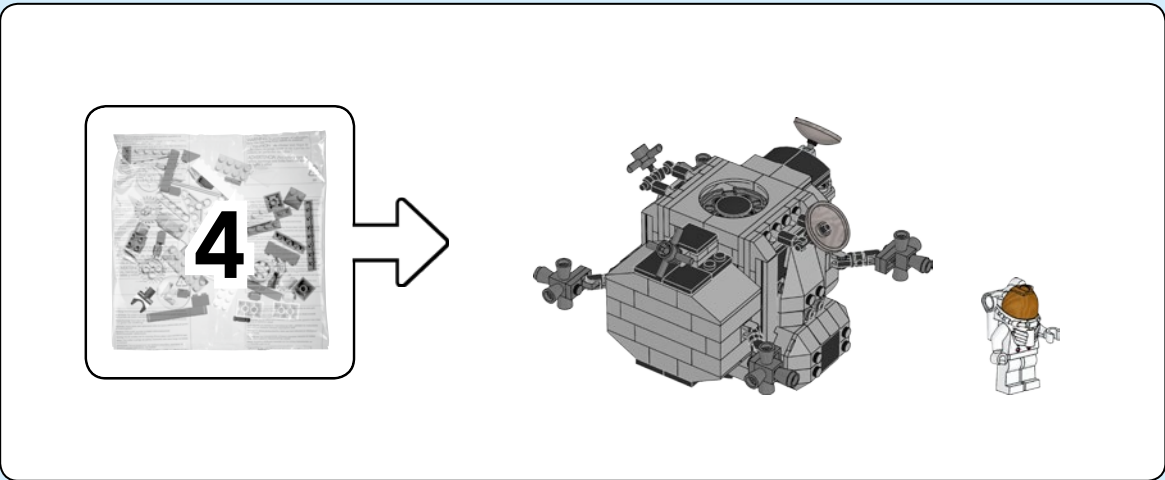

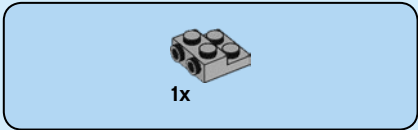
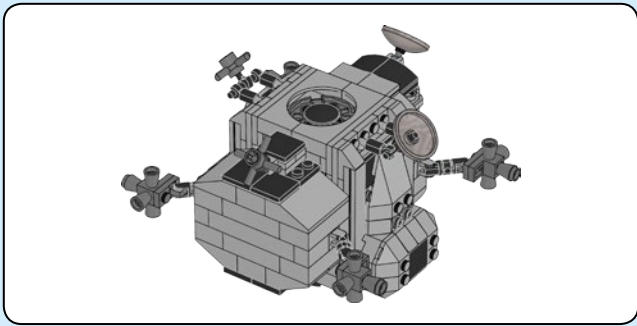

116

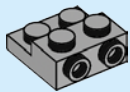

117

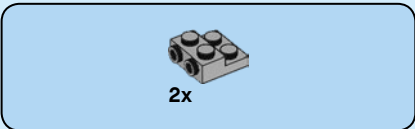
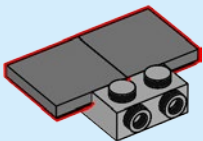

118

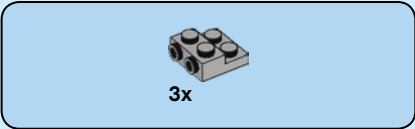
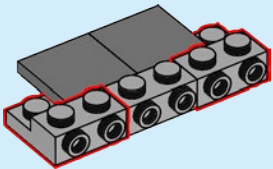

119

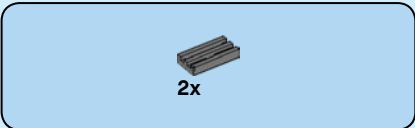
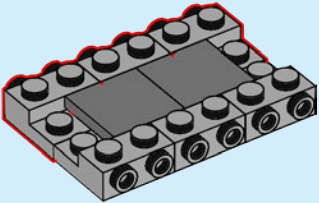

120

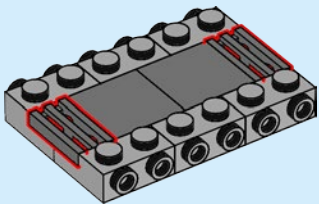

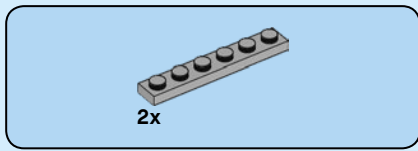

121

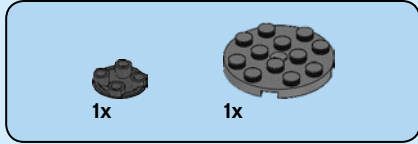
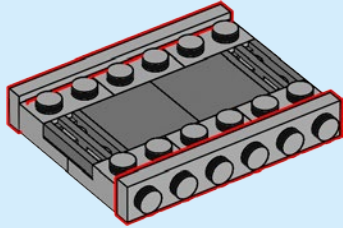

122

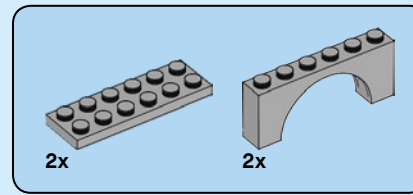
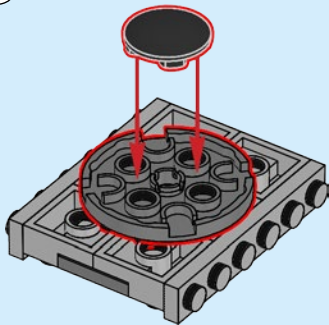

123

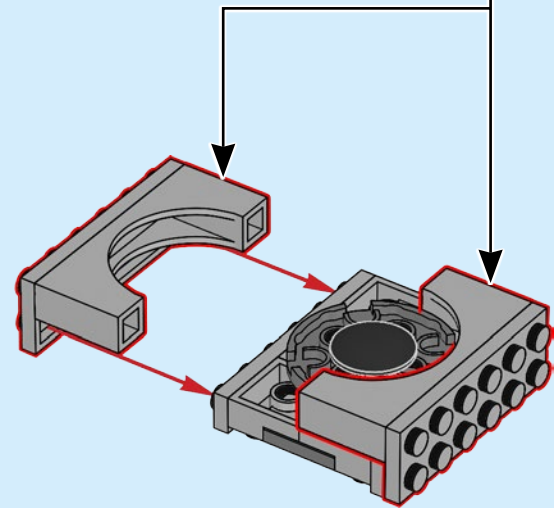
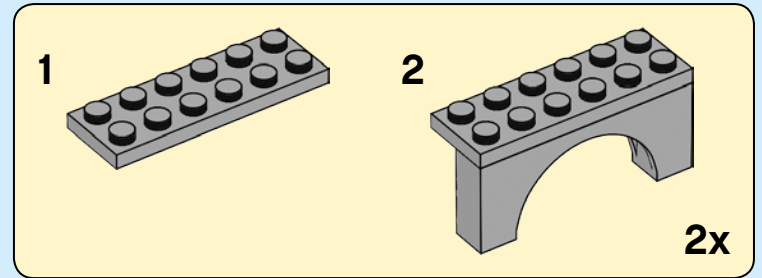

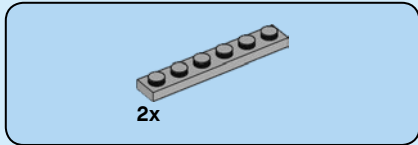
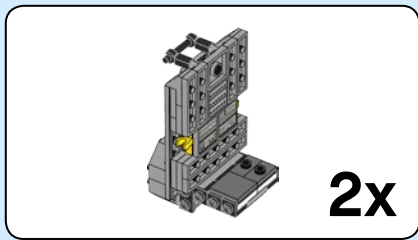

124

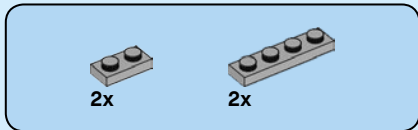
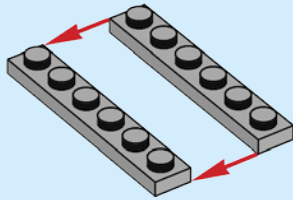

125

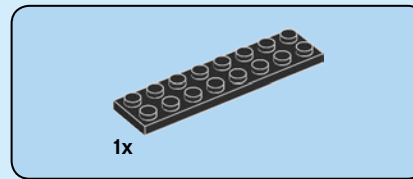
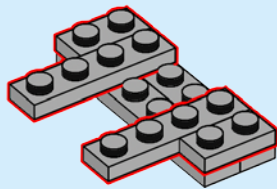

126

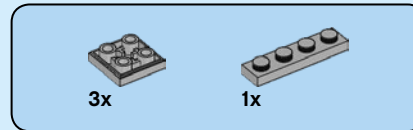
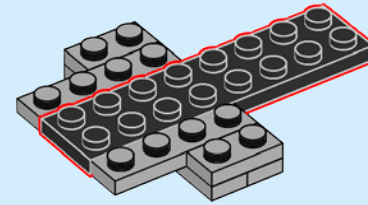

127

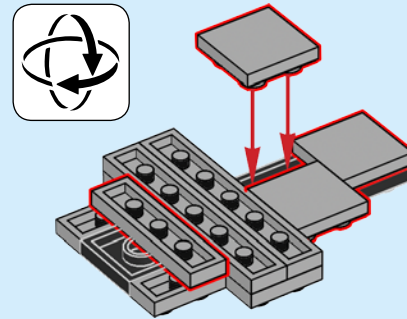



128

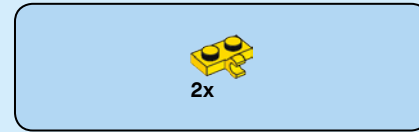
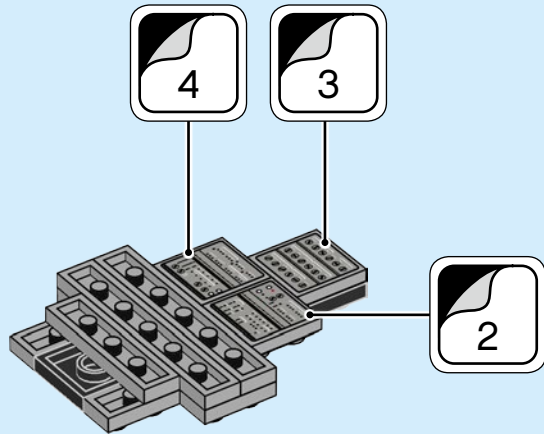

129

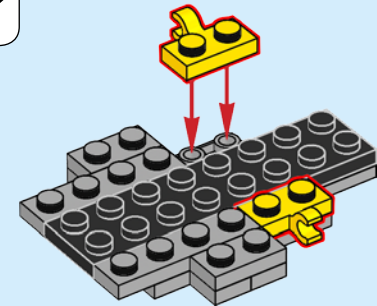
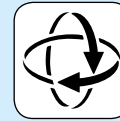

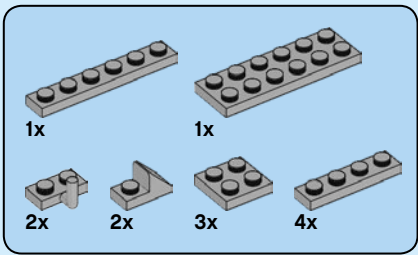

# 130

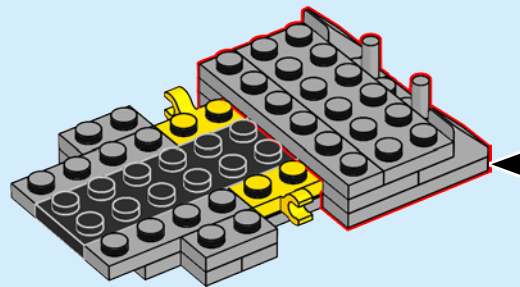
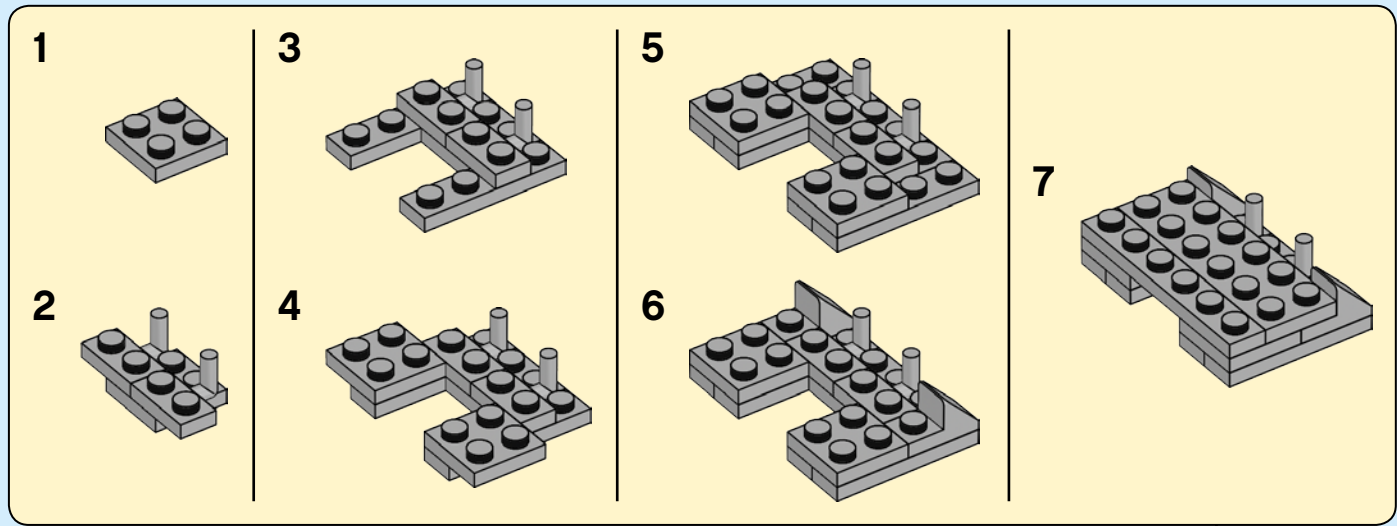

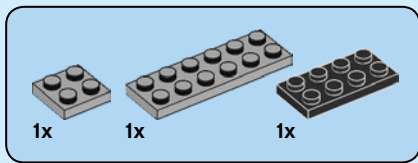

131

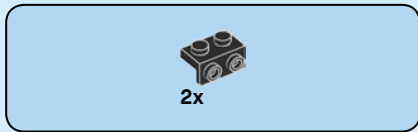
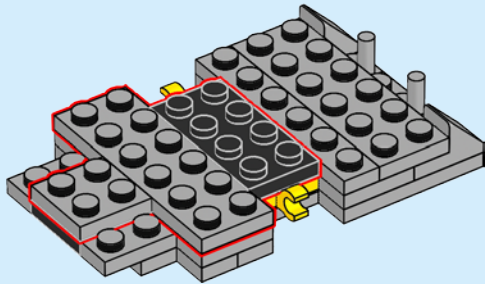

132

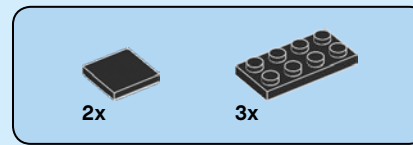
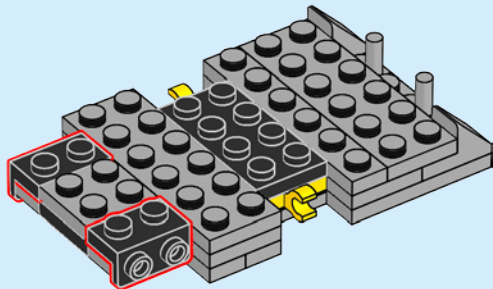

133

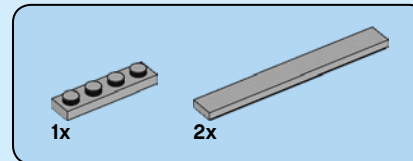
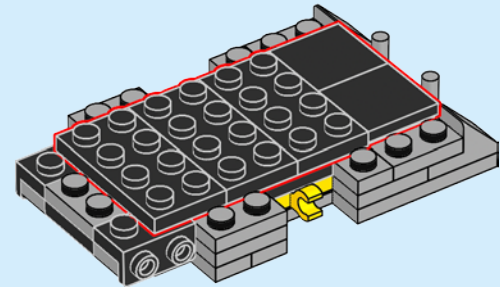

134

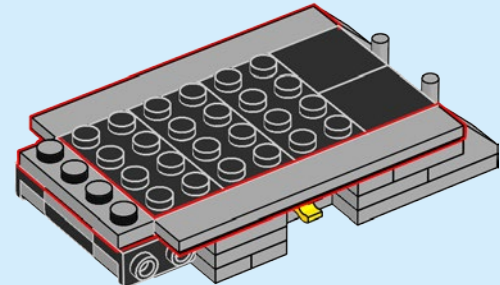

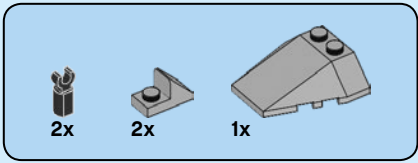

# 135

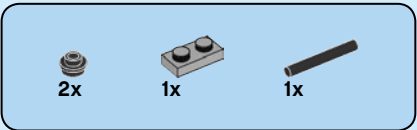
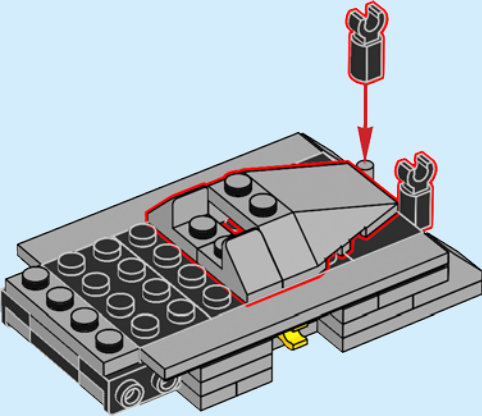

# 136

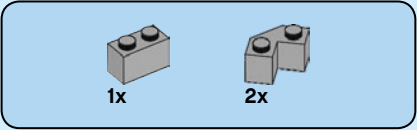
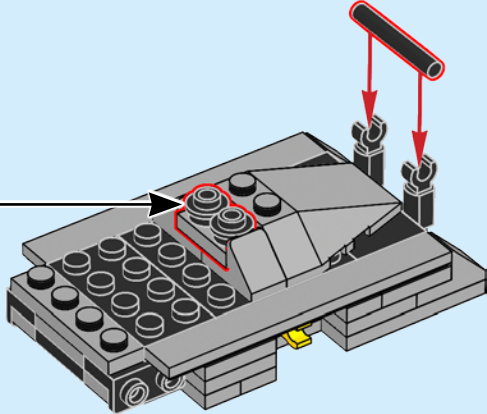
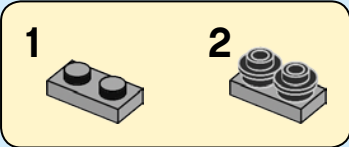

# 137

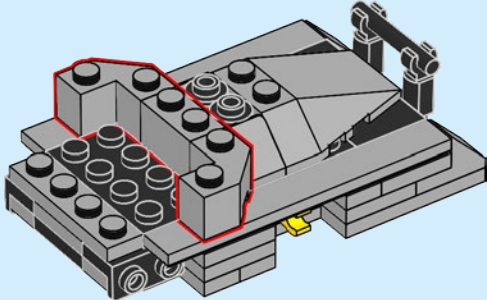





138

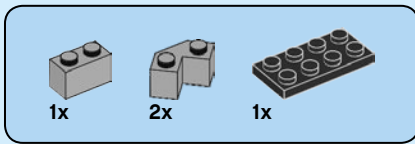
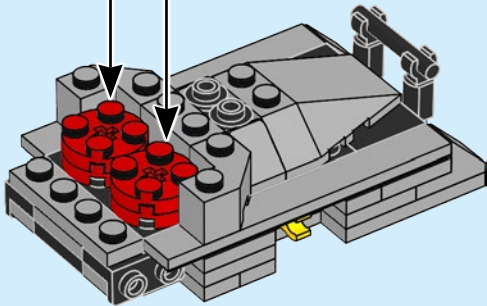
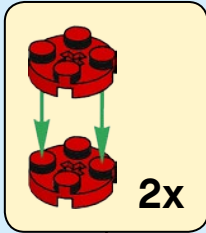

139

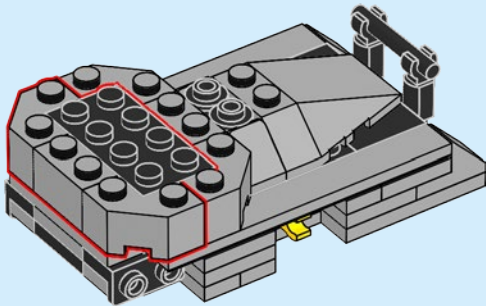

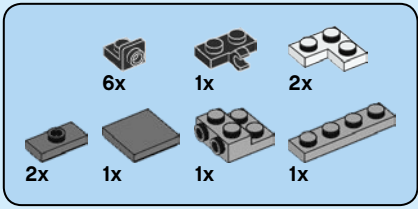

# 140

1

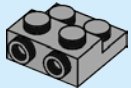

2

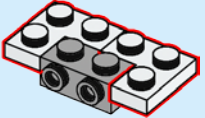

3

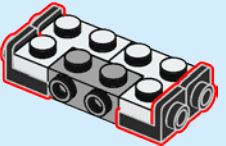

4

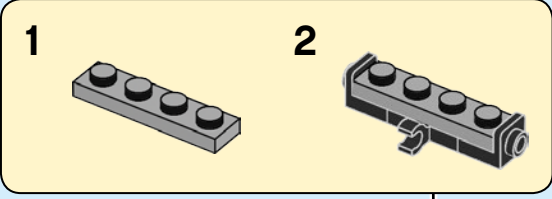
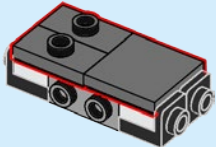

5

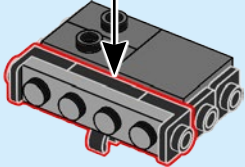

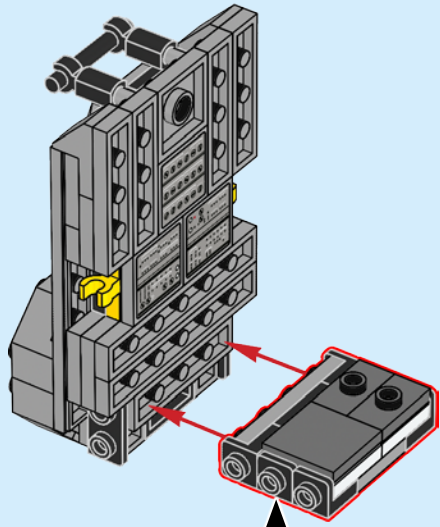

**2x**

**141**

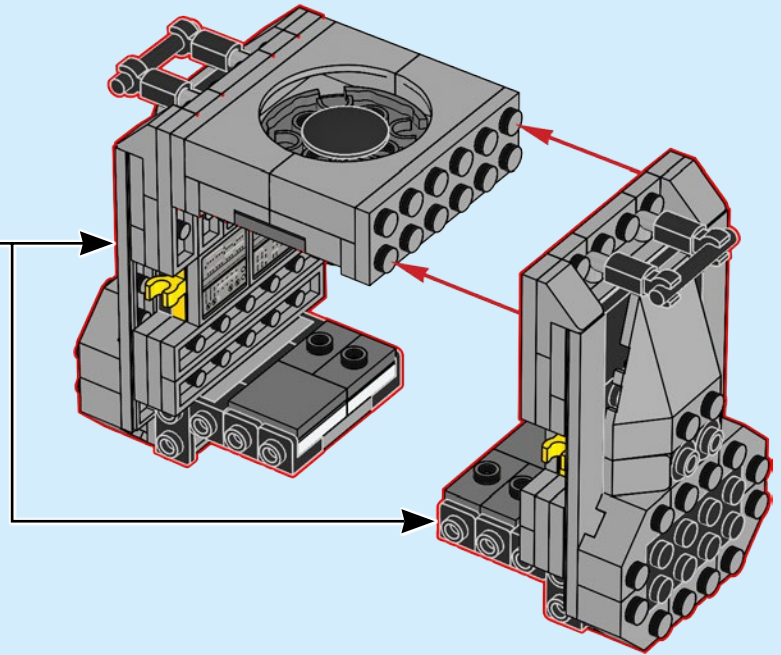

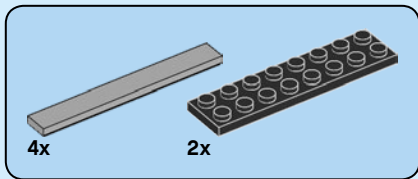

142

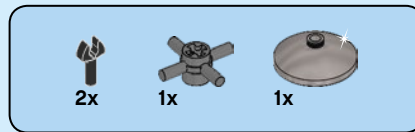
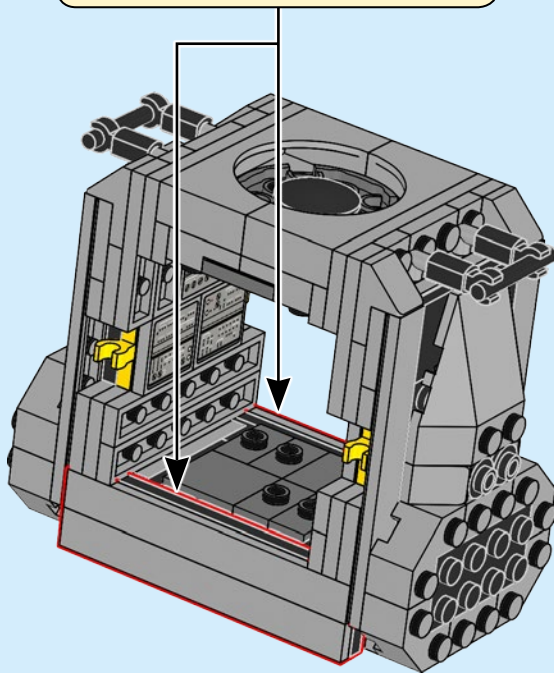
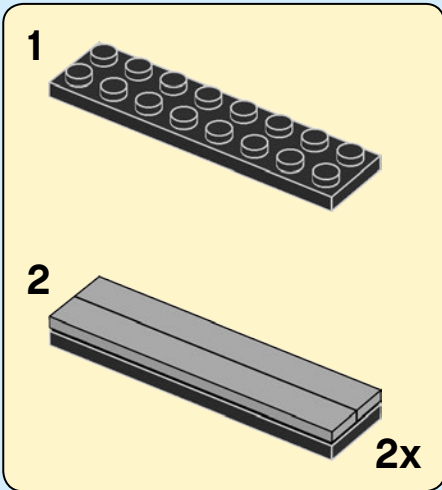

143

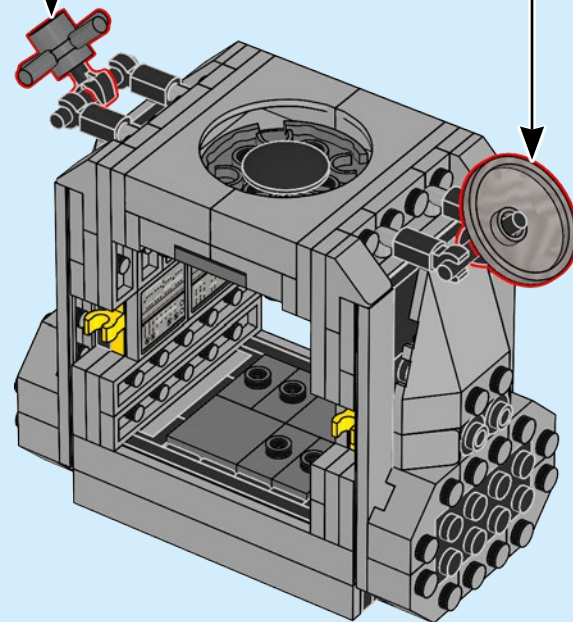
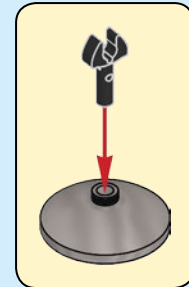
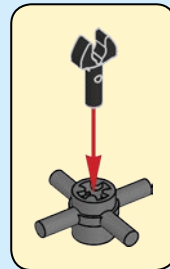



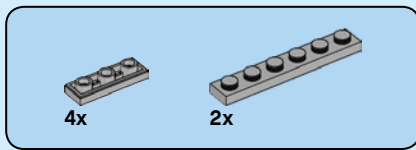

# 144

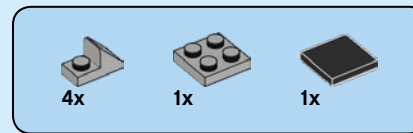
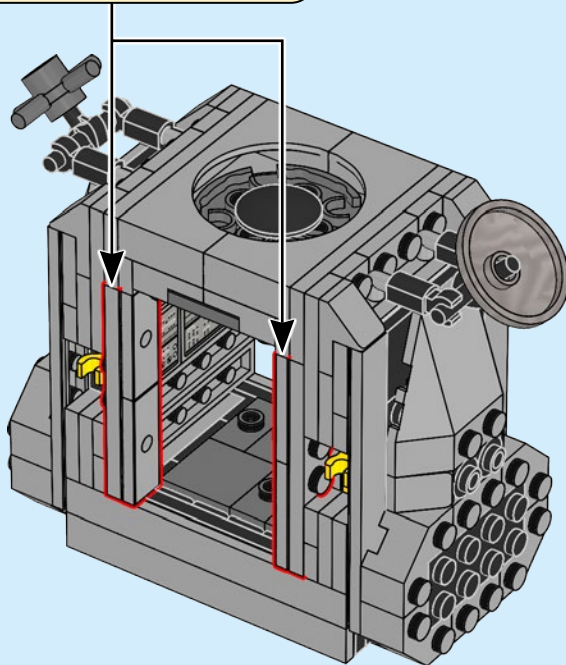
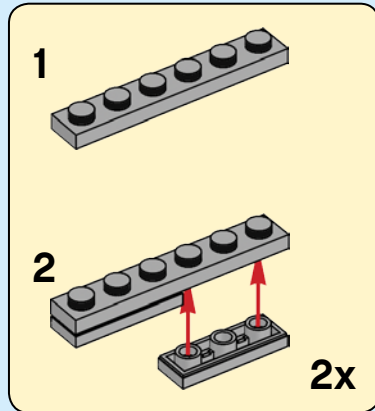

# 145

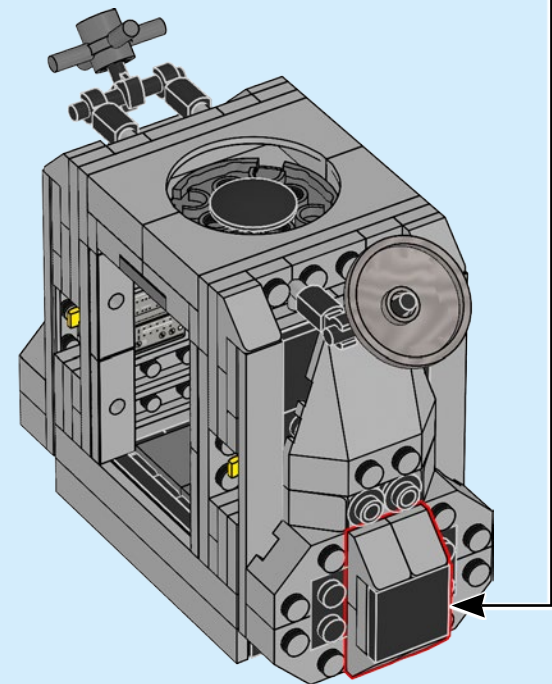
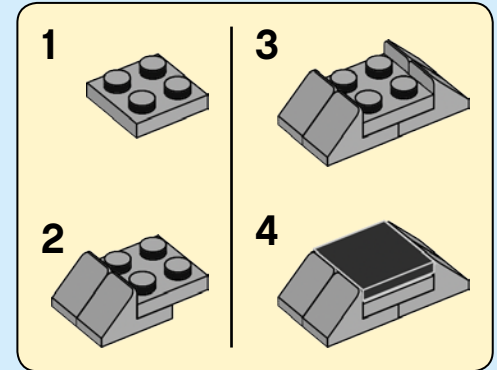



146

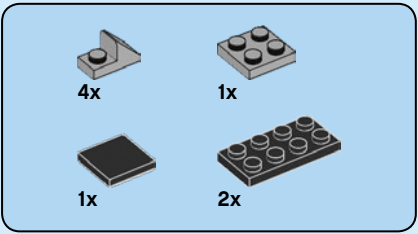
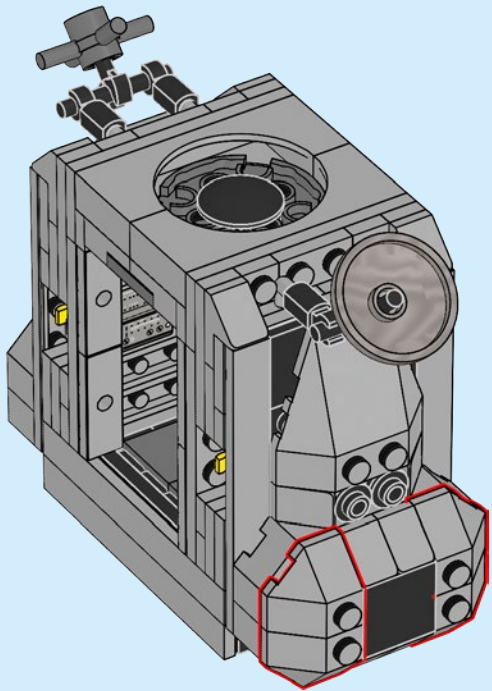

147

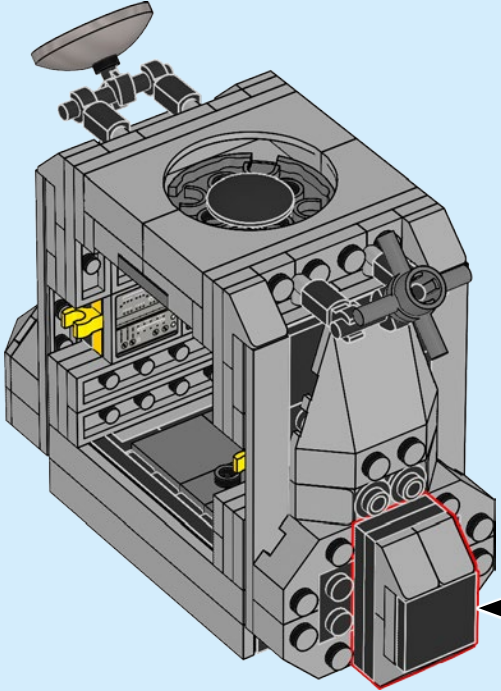
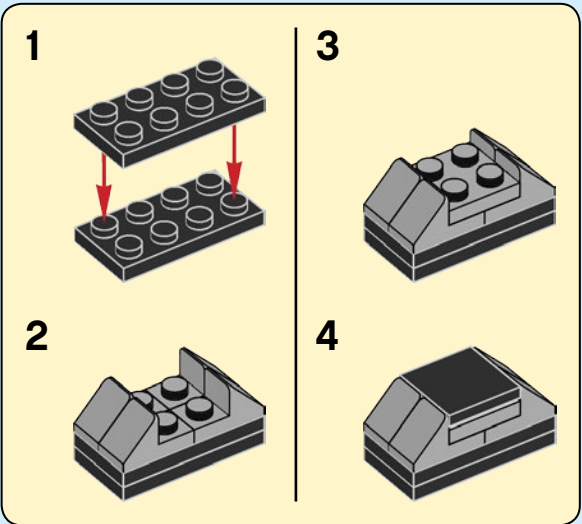

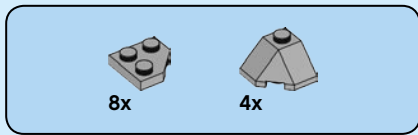

148

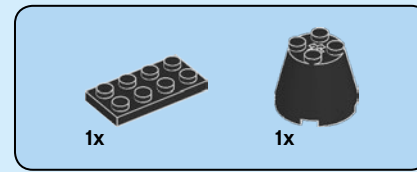
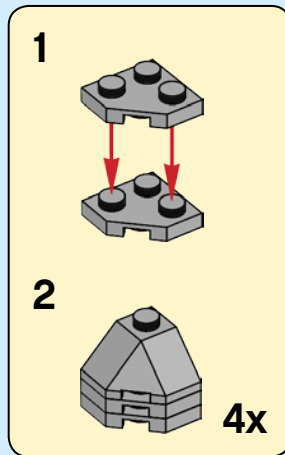
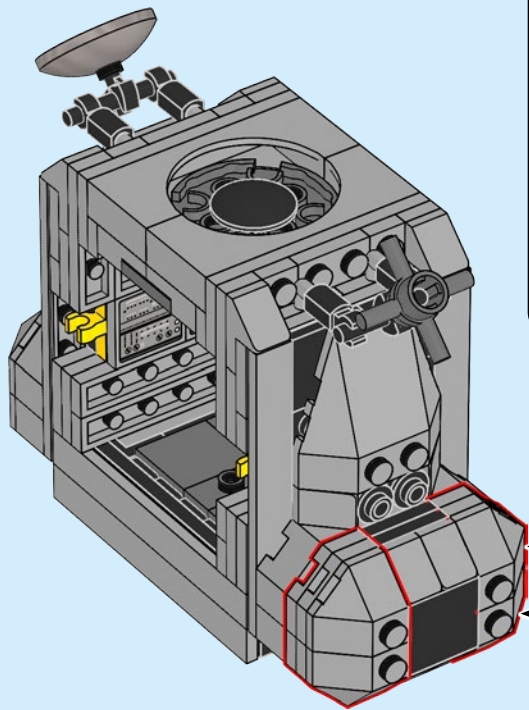

149

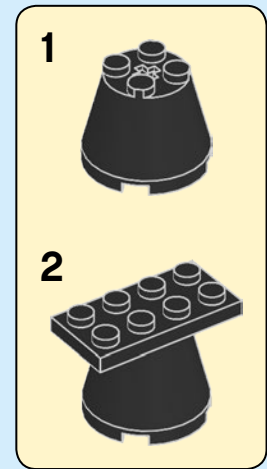
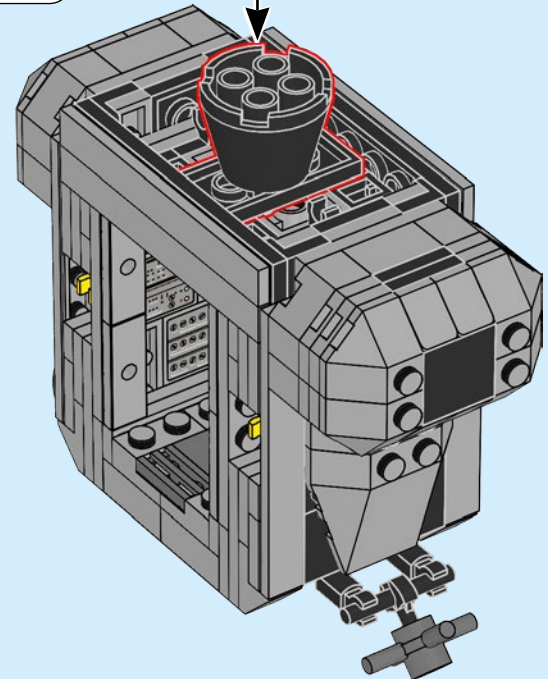
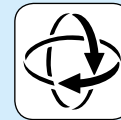

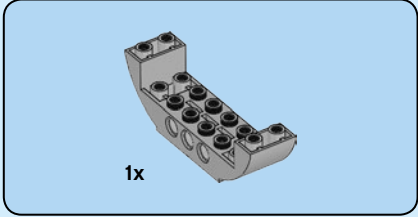
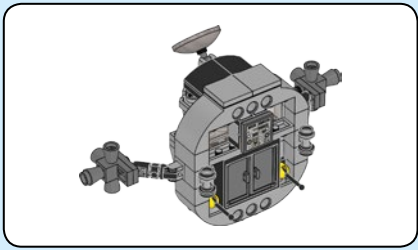

1x

150

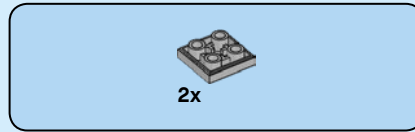
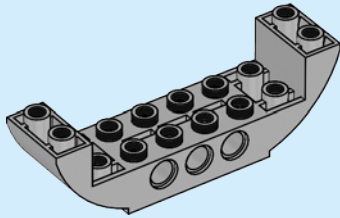

2x

151

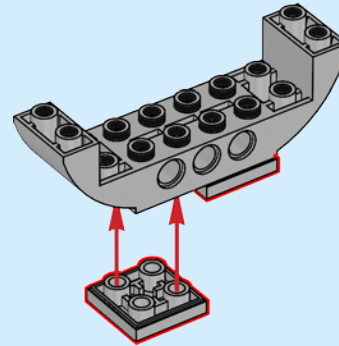



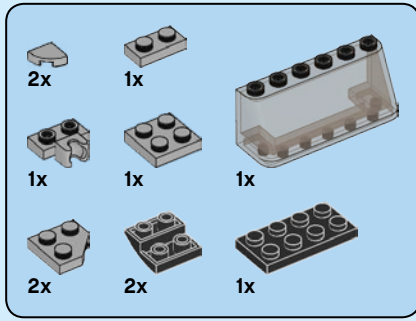

# 152

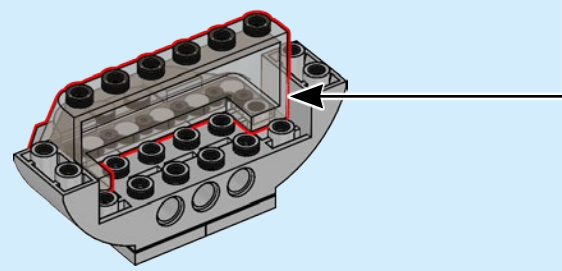
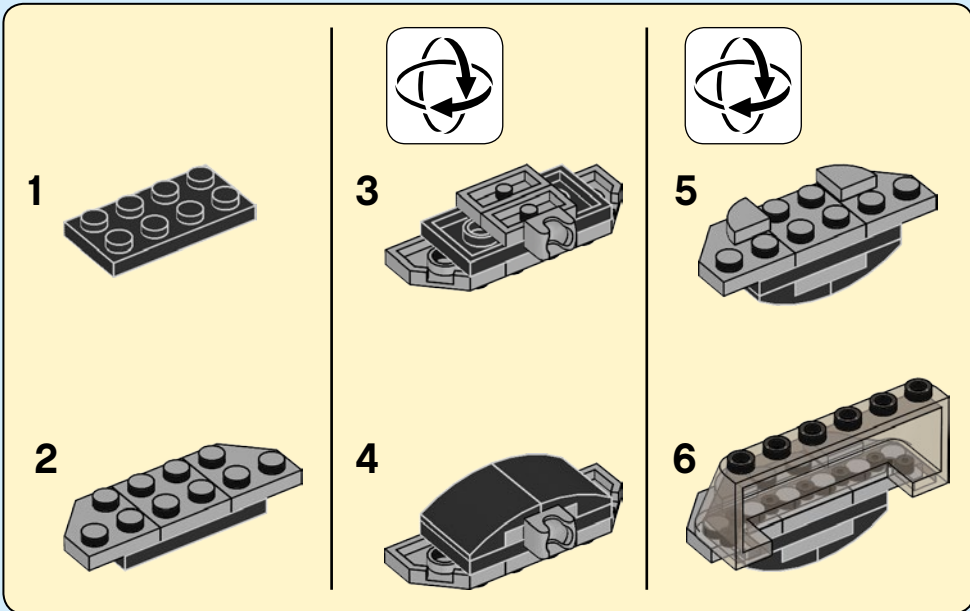

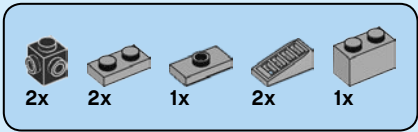

# 153

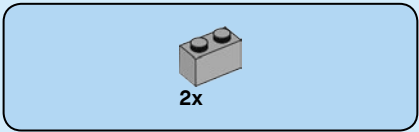
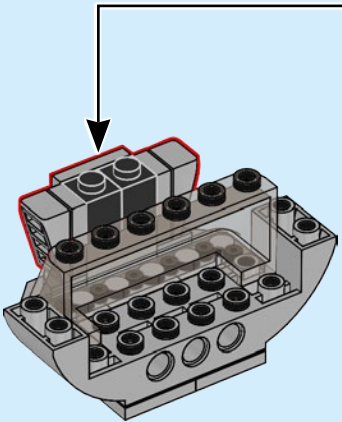
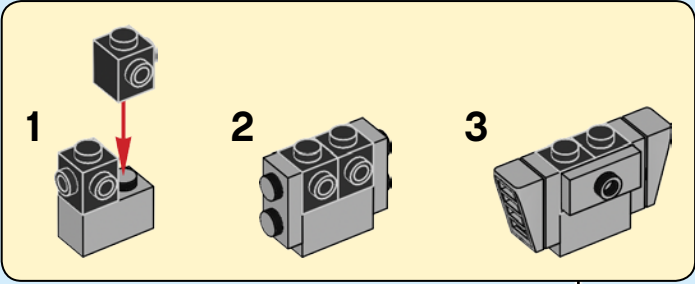

# 154

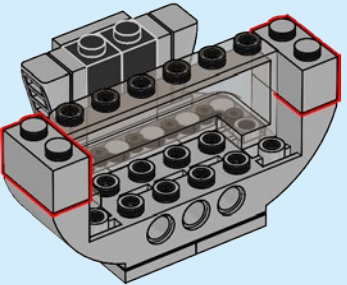

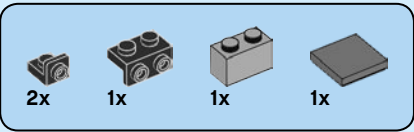

# 155

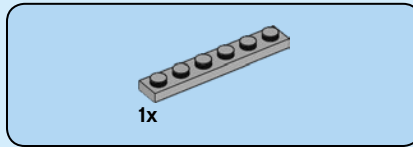
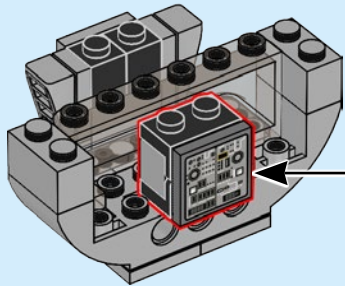
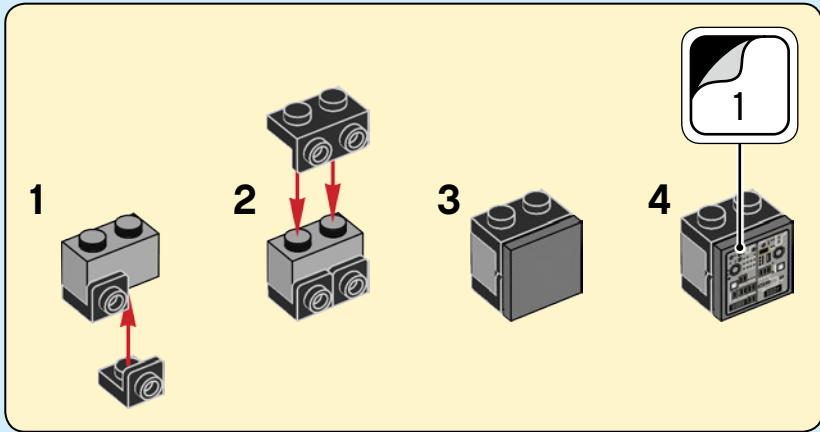

# 156

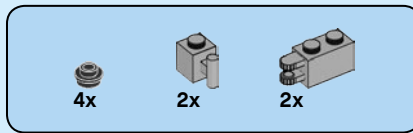
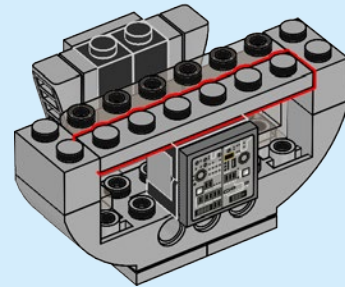

# 157

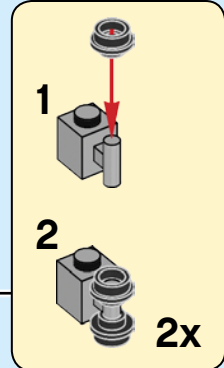
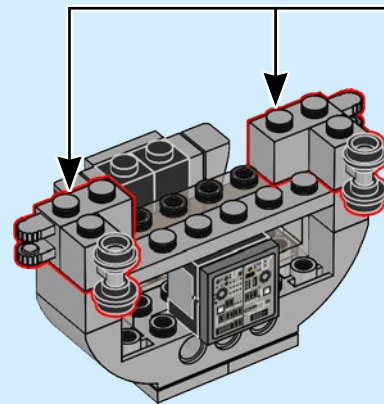

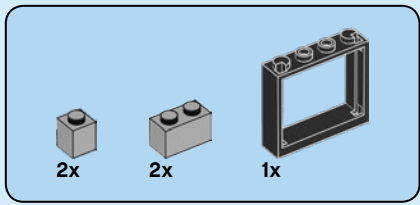

158

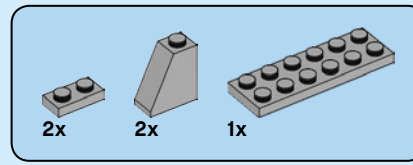
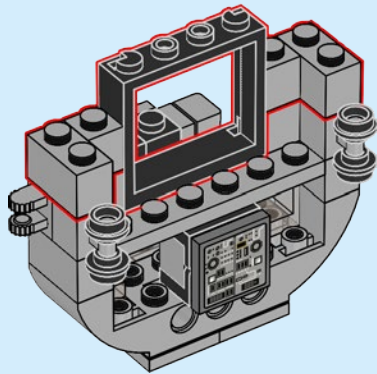

159

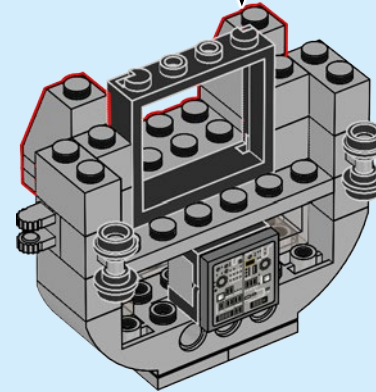
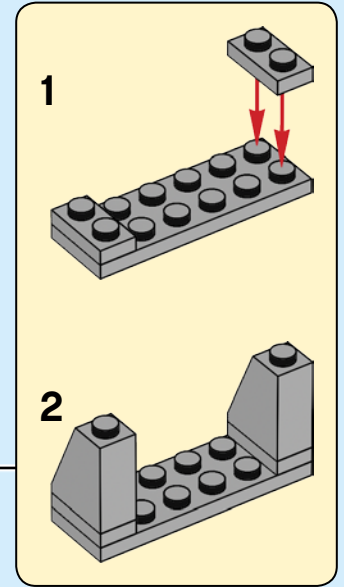



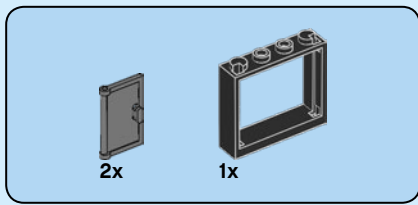

160

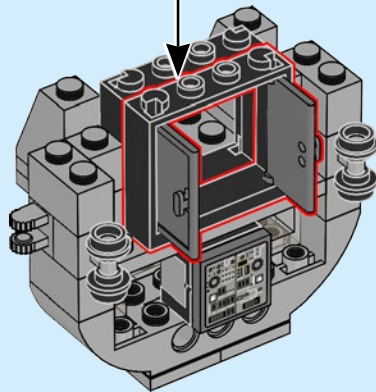
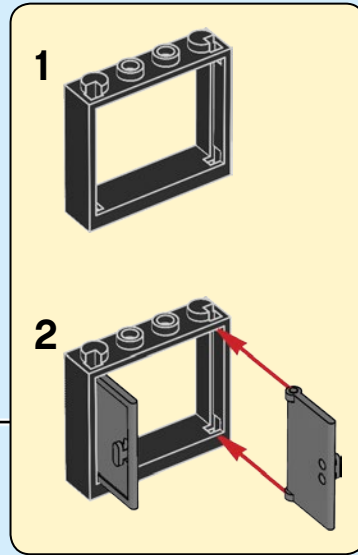

161

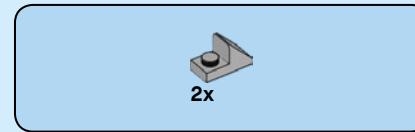
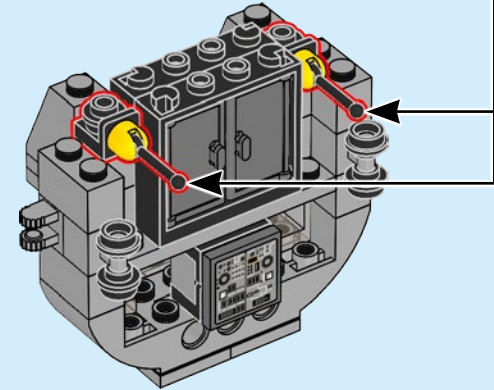
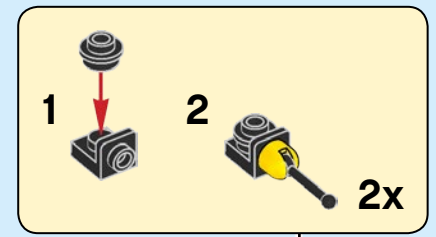

162

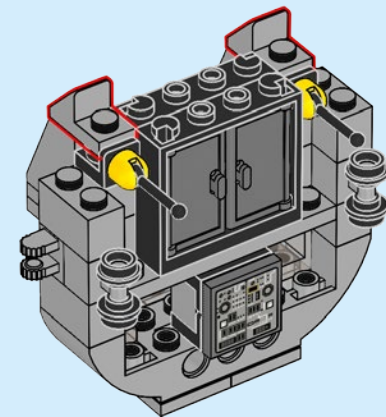

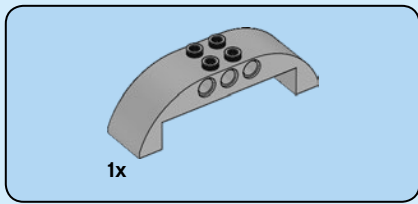

163

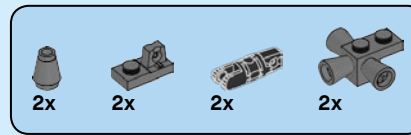
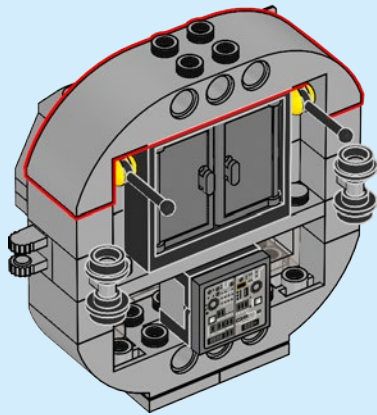

164

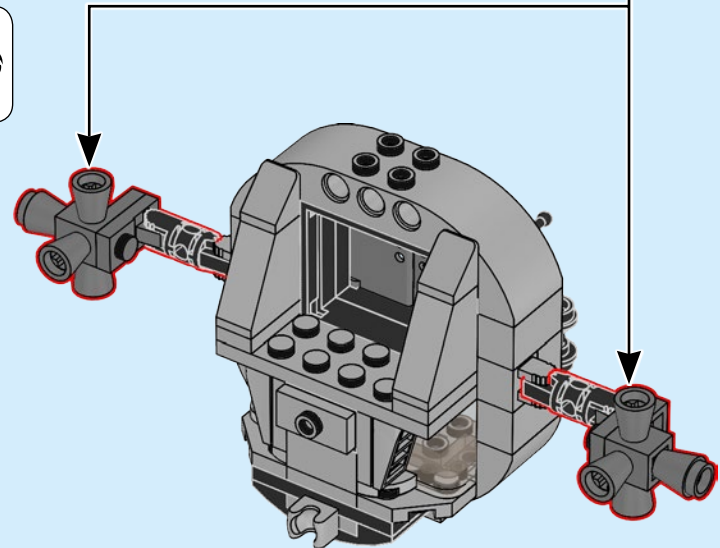
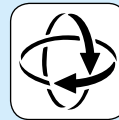
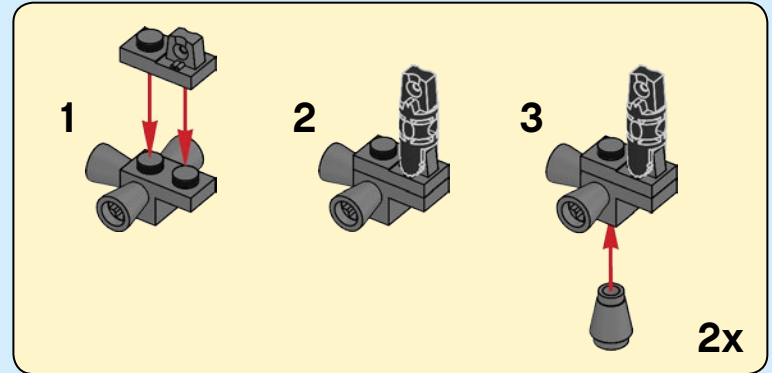

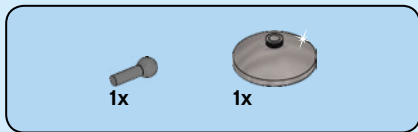

165

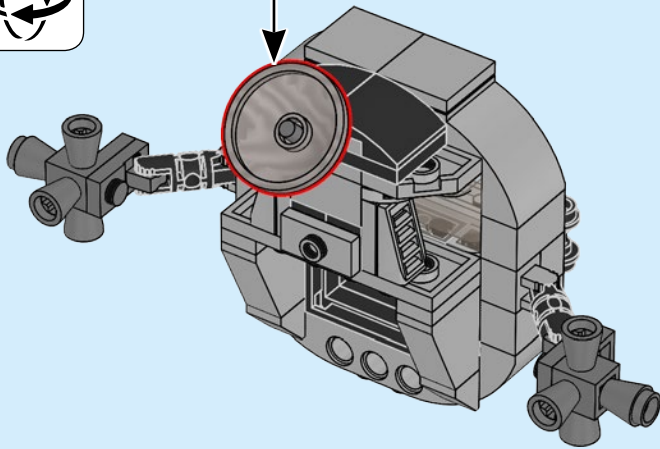
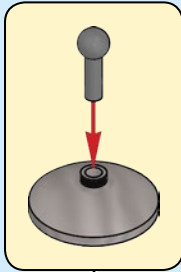

166

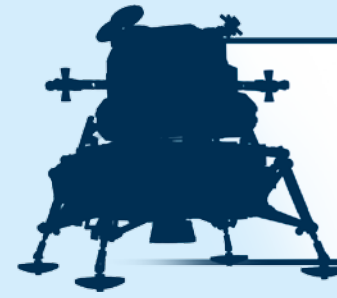

The reaction control system (RCS) provides thrust to a spacecraft, allowing it to be steered in the right direction. This system was used by the Apollo Lunar Lander when descending to the Moon.

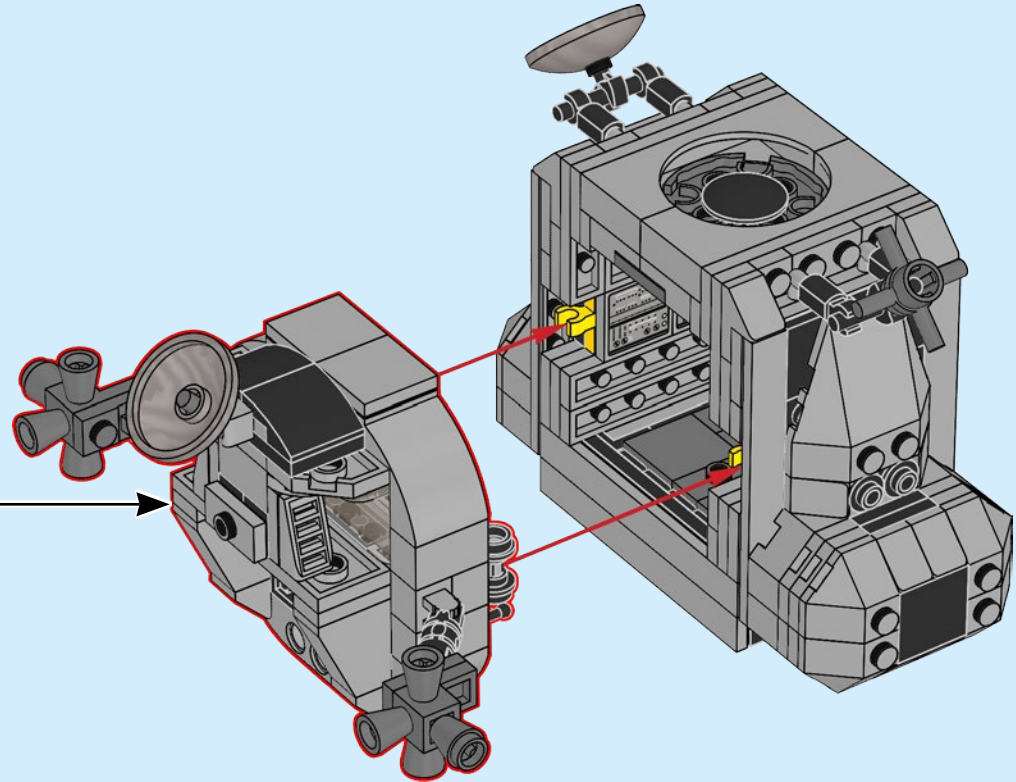

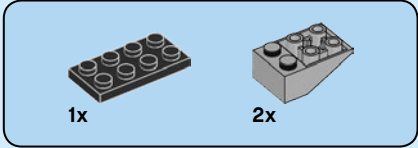
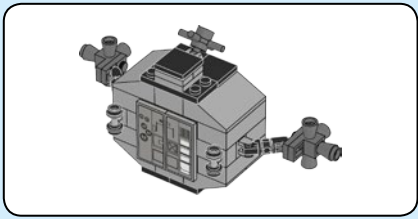

167

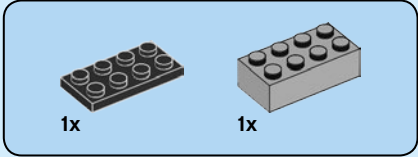
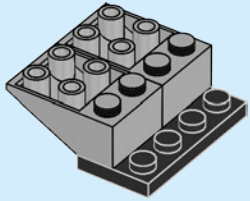

168

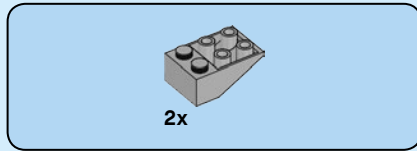
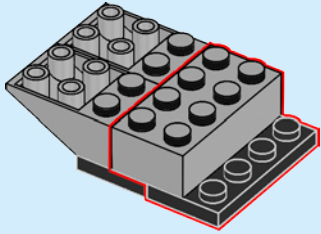

169

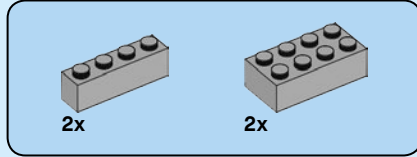
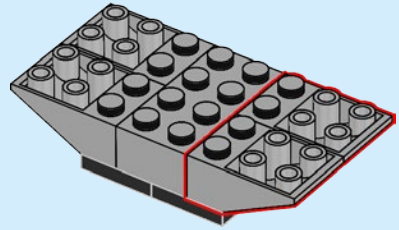

170

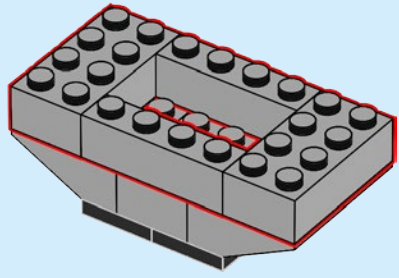



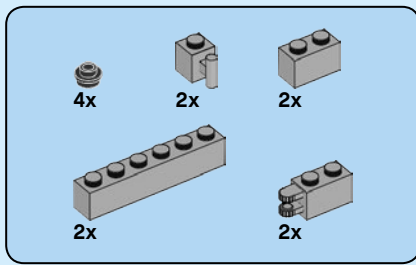

171

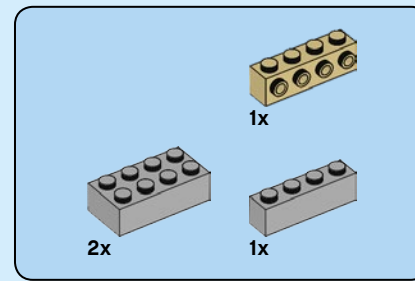
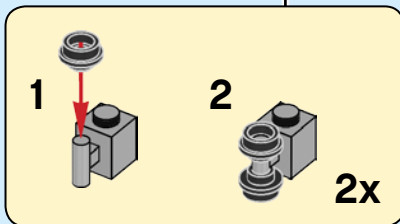
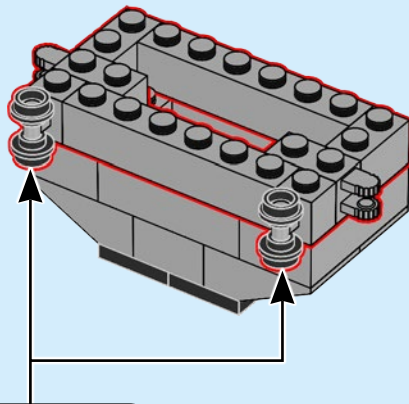

172

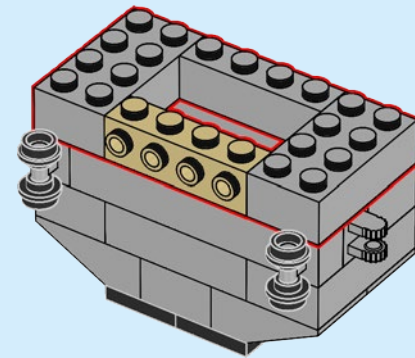

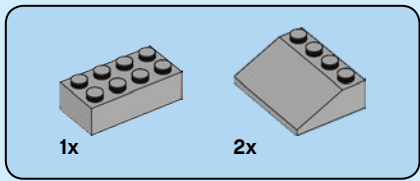

173

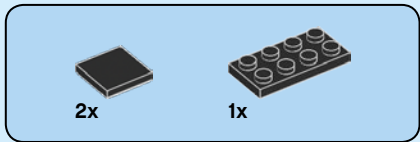
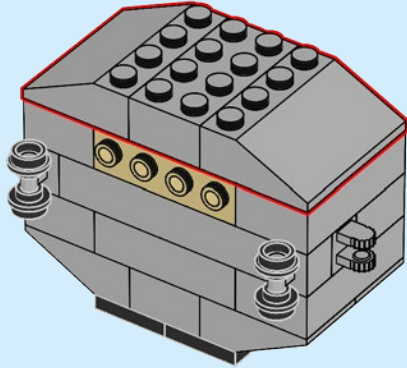

174

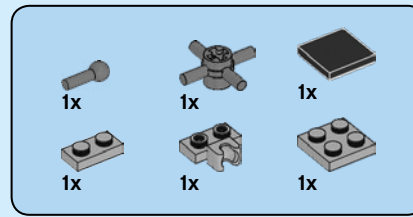
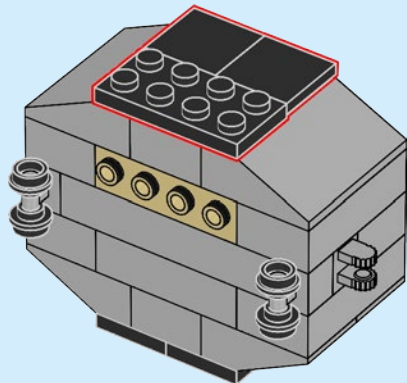

175

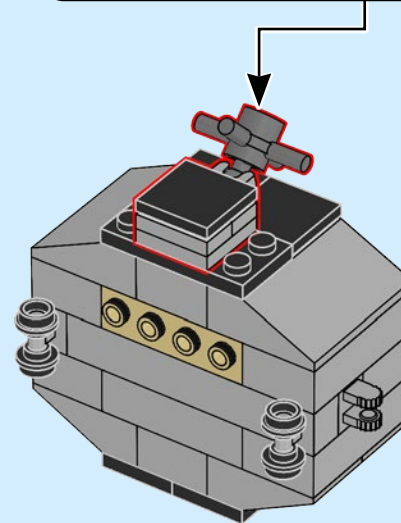
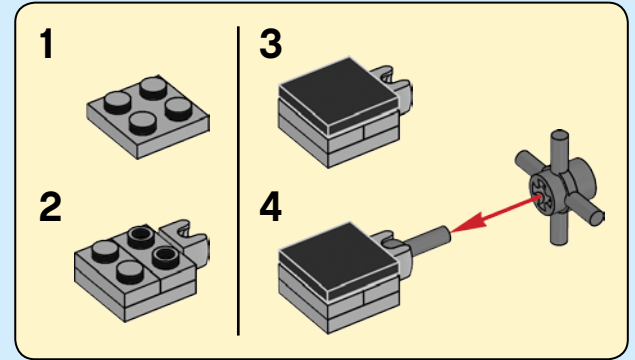

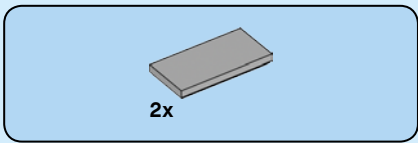

176

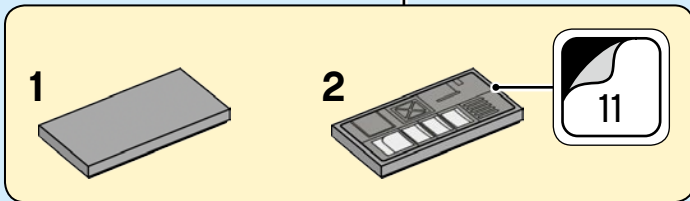
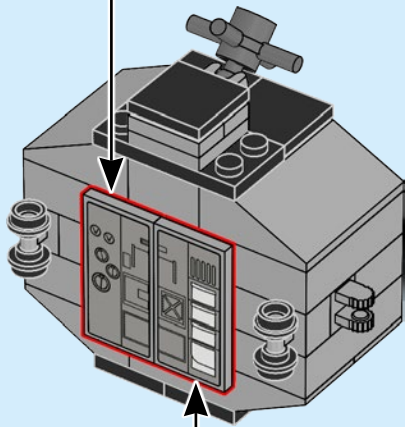
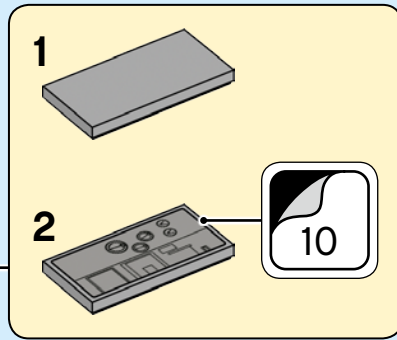

177

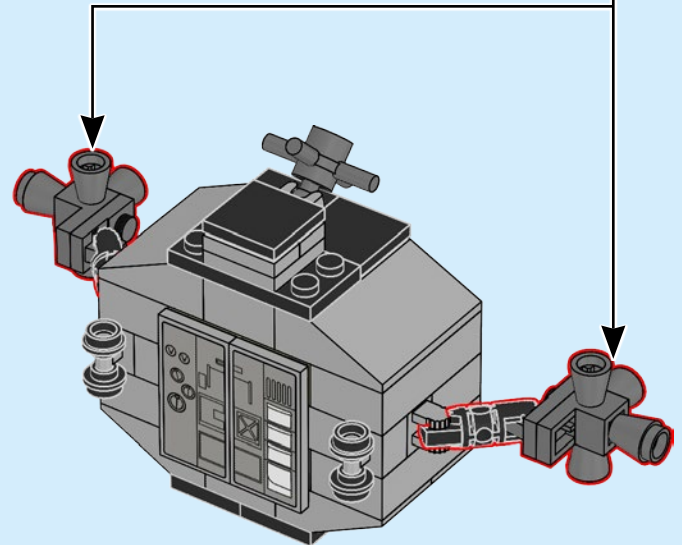
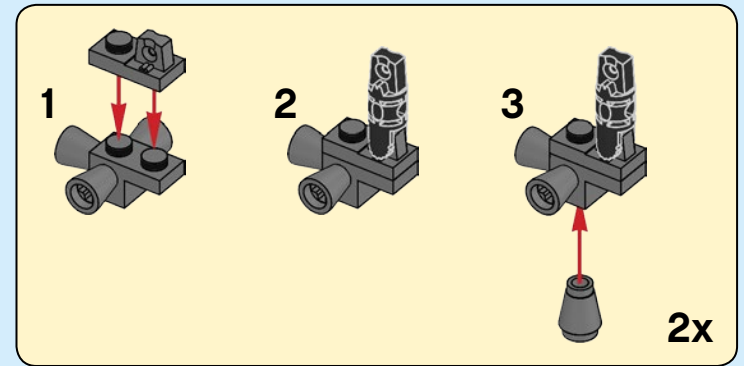

178

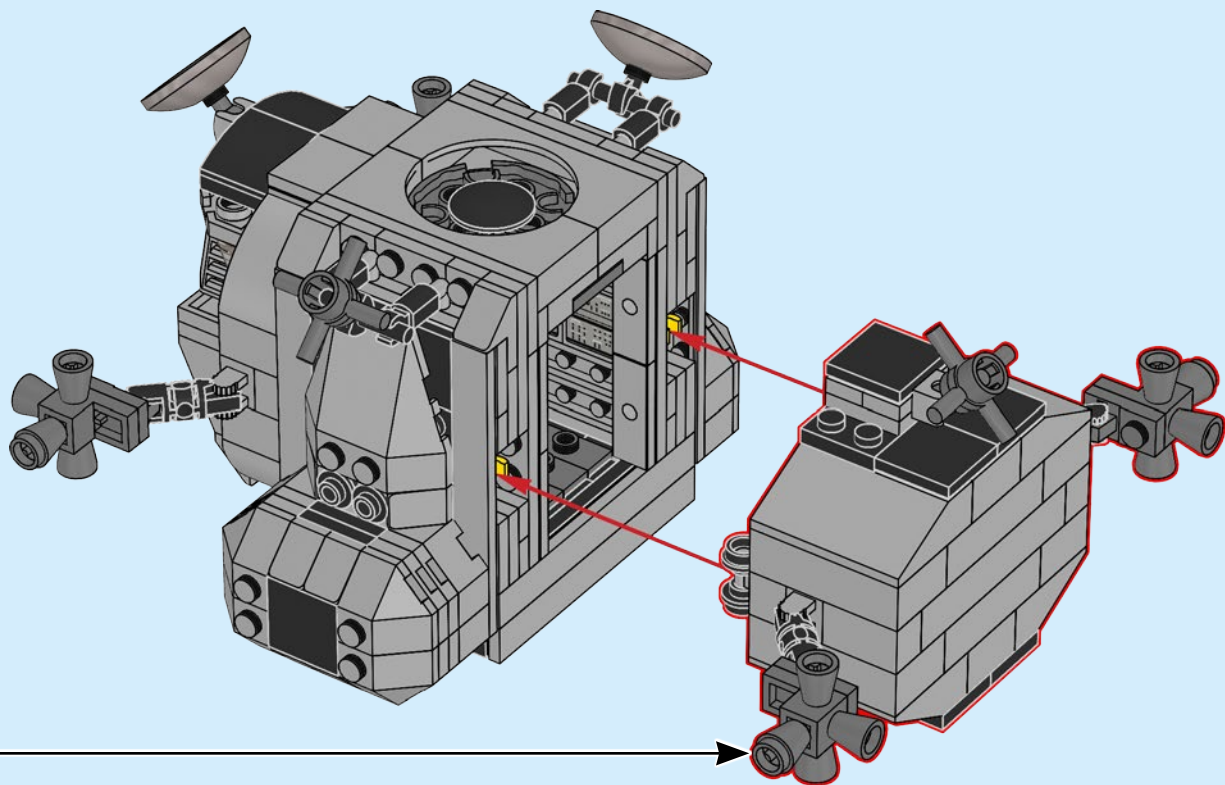



179

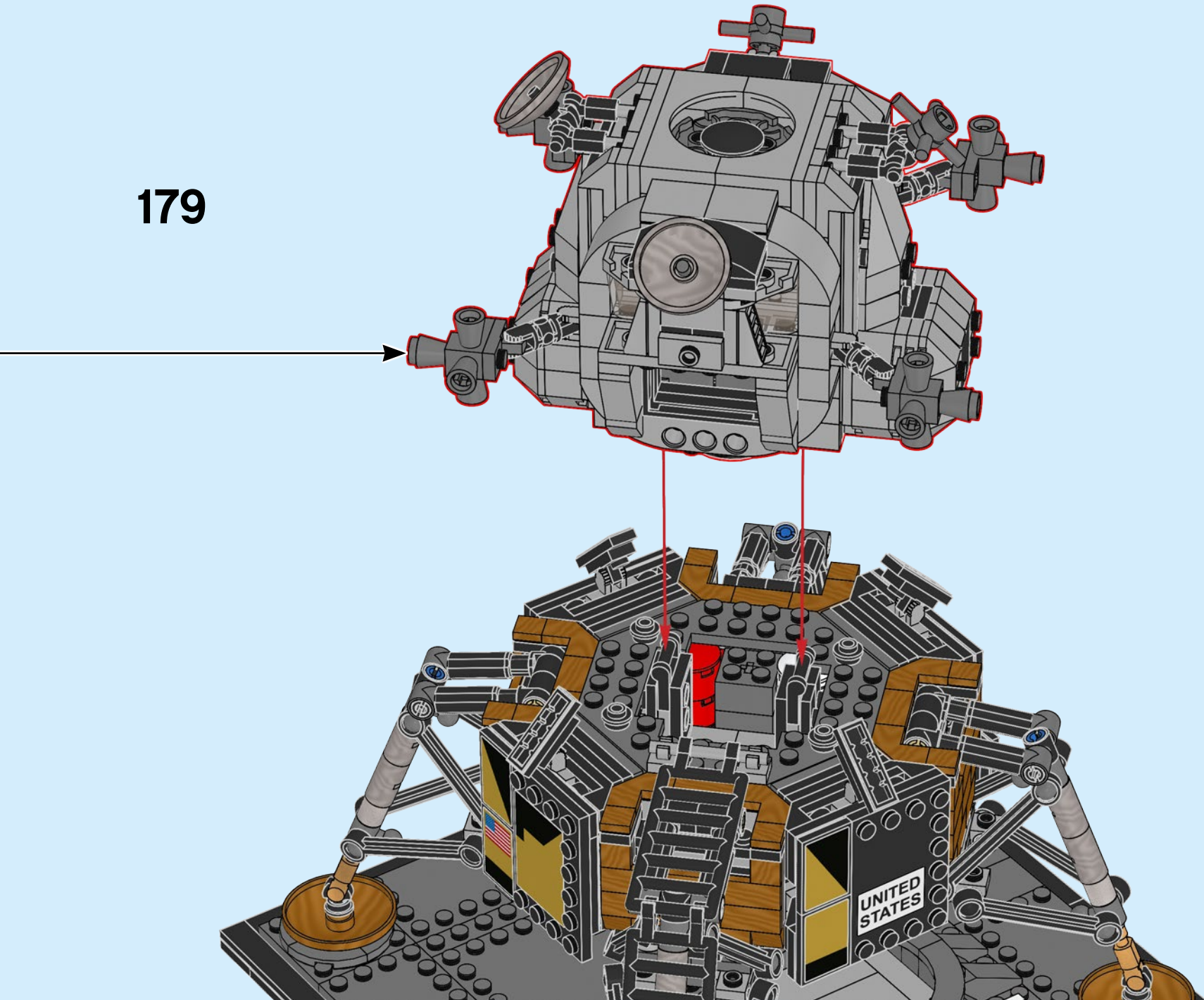

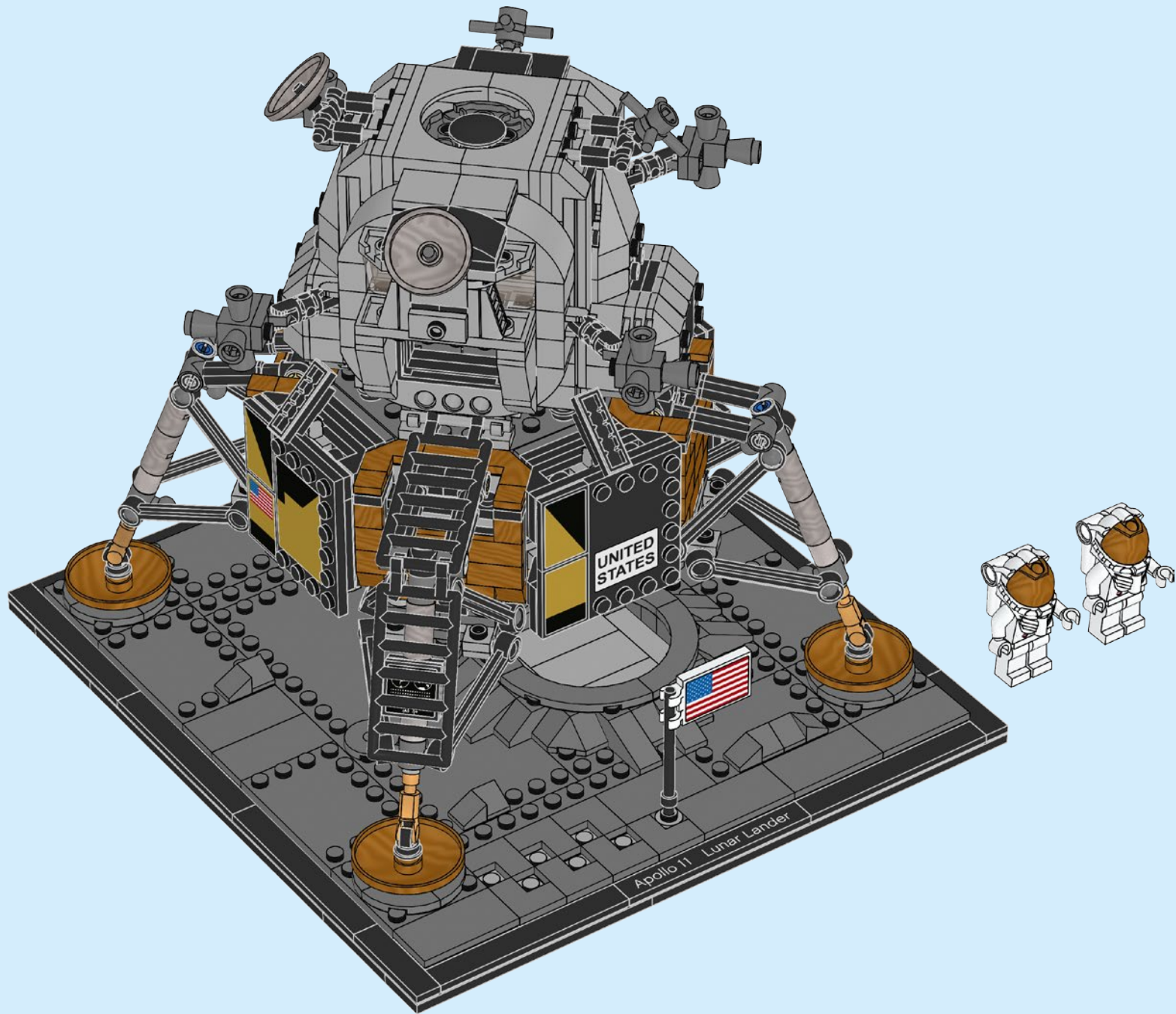



1

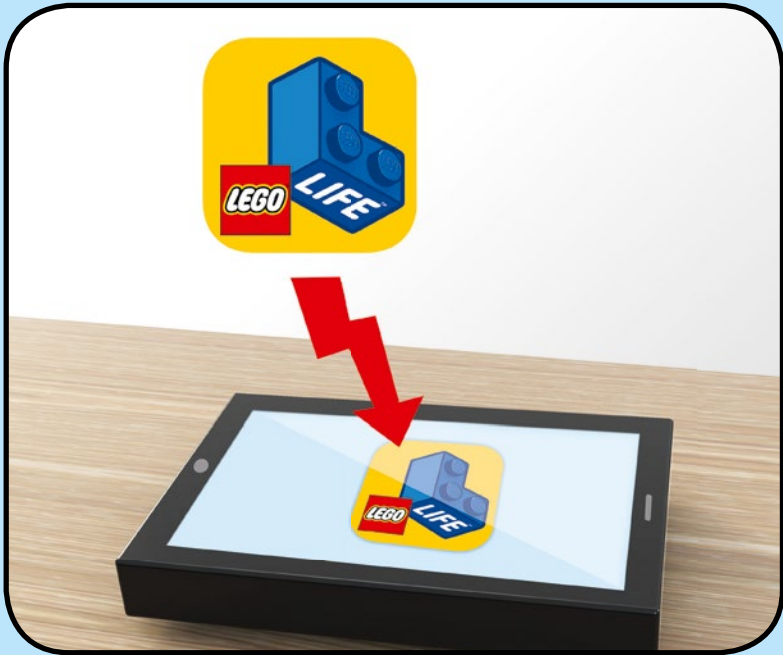

2



3



1x 6177114	8x 6013938	1x 6170421	4x 6092585	1x 4500978	4x 6064228	8x 6284071	18x 6093859
1x 6224811	4x 4113917	2x 74156	8x 6114987	8x 362326	6x 379526	5x 6168647	2x 4515374
2x 4278271	12x 6174925	4x 6015891	4x 4144575	4x 6199908	4x 6131571	4x 6275844	12x 6168633
2x 6044691	8x 4114084	30x 6168646	8x 302326	12x 6162892	4x 6131571	4x 4211483	12x 6168633
4x 6218899	1x 4201062	6x 6278152	6x 6132731	28x 302126	1x 6267596	2x 6176433	22x 4211388
2x 9327	2x 4278275	4x 4560174	5x 6016172	2x 243126	11x 416226	2x 6071229	1x 6066097
1x 6146215	8x 4142865	2x 6187572	4x 4507820	4x 4560182	4x 416226	2x 4211389	12x 4211398
4x 6178921	8x 403221	16x 6234695	2x 4225201	2x 4530589	4x 4100378	4x 6170569	2x 6092111
1x 306901	4x 6173922	8x 4184169	2x 6093525	12x 6280168	2x 602026	8x 6248078	1x 4654046
1x 6013866	2x 6066342	8x 4660886	10x 306826	1x 4560182	4x 602026	4x 6248890	8x 4211437
2x 4600121	4x 6196217	1x 4278359	4x 6211476	33x 302026	4x 303426	4x 4594238	4x 4611702
4x 242001	2x 403223	1x 4653822	4x 6192346	16x 4629921	2x 383226	1x 4650645	8x 4651063
2x 6267589	4x 4514553	5x 403226	1x 281726	4x 366626	2x 6043656	2x 6043656	4x 6078264
2x 300201	1x 6100222	12x 4121715	2x 242026	1x 663626	9x 428226	4x 4515341	8x 6132886
1x 4599983	1x 4651441	8x 4512363	1x 4650145			10x 6186657	16x 4211397



16x  
4211353



8x  
6034676



8x  
6043639



8x  
4654577



4x  
6251044



2x  
6254807



1x  
6116608



4x  
6093058



4x  
4211570



2x  
4211356



3x  
4211394



40x  
4211445



5x  
4560183



4x  
4211395



6x  
4211385



2x  
4211420



2x  
6030235



2x  
4211393



2x  
6106189



11x  
4211438



7x  
4211452



4x  
4211570



1x  
6202481



8x  
4211481



1x  
6171081



1x  
4211449

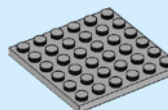

4x  
4211474

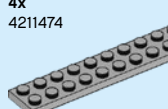

2x  
4211360



2x  
4211401



1x  
4662161

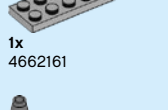

4x  
4529240

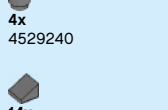

14x  
4504378



2x  
4521386

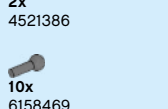

10x  
6158469



3x  
6055313

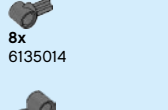

8x  
6135014

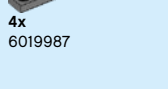

4x  
6019987

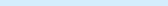

4x  
6092572



4x  
4210726



2x  
4210631



10x  
4211063



8x  
4211135



8x  
6055629



8x  
6123814



2x  
4222192



5x  
4211055



4x  
6227909



16x  
6265306



7x  
6247784



4x  
6263924



8x  
4211045



4x  
4211024



1x  
6083620



1x  
4528323

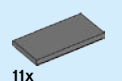

11x  
4560184



4x  
6186825

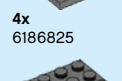

4x  
4243831



4x  
6232146

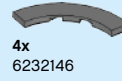

4x  
4211115

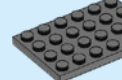

7x  
6199511

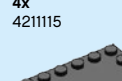

2x  
4257526



2x  
4211061



2x  
6172931

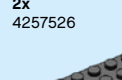

4

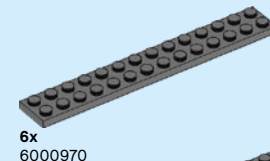

6x  
6000970

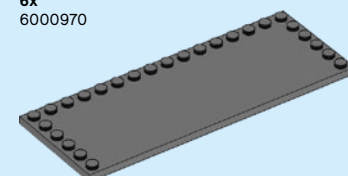

1x  
6037386

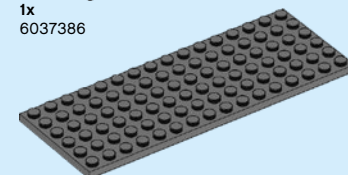

1x  
4226358

4x  
6161155



1x  
6197966



1x  
6020990



7x  
6204673



2x  
6051541



1x  
6240515



1x  
6240515



4x  
6170470

4x  
6197509



8x  
6186672



16x  
6264167



8x  
6191668



36x  
6265247



2x  
6263432



8x  
6265604



4x  
6265601



Customer Service

Kundenservice

Service Consommateurs

Servicio Al Consumidor

LEGO.com/service or dial



: 00800 5346 5555

: 1-800-422-5346

# WIN

GO TO [WWW.LEGO.COM/PRODUCTFEEDBACK](http://WWW.LEGO.COM/PRODUCTFEEDBACK) AND  
GIVE US YOUR SHORT **FEEDBACK** ABOUT THIS  
LEGO® SET FOR A CHANCE TO WIN  
A COOL LEGO PRIZE.

Terms & Conditions apply

## [LEGO.com/productfeedback](http://LEGO.com/productfeedback)



### GEWINNE

Erzähle uns auf  
[www.LEGO.com/productfeedback](http://www.LEGO.com/productfeedback)

etwas über die Erfahrungen, die  
du mit diesem LEGO® Set gemacht  
hast, und sichere dir die Chance  
auf einen coolen LEGO Preis!

Es gelten die  
Teilnahmebedingungen

### GAGNE

Rends-toi sur  
[www.LEGO.com/productfeedback](http://www.LEGO.com/productfeedback)

et donne-nous quelques com-  
mentaires sur ce produit LEGO®  
pour avoir une chance de gagner  
un prix LEGO !

Voir Conditions Générales

### GANAN

Visita  
[www.LEGO.com/productfeedback](http://www.LEGO.com/productfeedback)

y envíanos tu opinión acerca de  
este set LEGO®. ¡Participarás en el  
sorteo de un premio LEGO!

Términos y Condiciones aplicables

### 获取奖品

登录  
[www.LEGO.com/productfeedback](http://www.LEGO.com/productfeedback)

给出关于此乐高®套装的简短反馈，  
就有机会获得炫酷乐高奖品

《条款及条件》适用

### 경품 당첨 기회

[www.LEGO.com/productfeedback](http://www.LEGO.com/productfeedback)

페이지로 이동하여 이 레고® 세트에  
대한 간략한 피드백을 보내 주시고  
멋진 레고 경품을 탈 수 있는 기회도  
잡으십시오

약관 적용

### ЗАПОЛНИ АНКЕТУ И ПОЛУЧИ ПРИЗ

Перейди по ссылке  
[www.LEGO.com/productfeedback](http://www.LEGO.com/productfeedback)

ответь всего на несколько во-  
просов об этом наборе LEGO®,  
и у тебя появится шанс выиграть  
замечательный приз от компании  
LEGO.

Применяются Условия и правила  
участия